

JT1220 Mach 1

Parts Manual

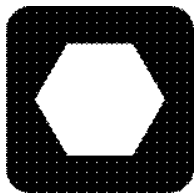

Ditch Witch[®]

JT1220 Mach 1

ISSUE NO. 15PL-07/11

For Replacement Copy Order **P/N 053-097**

This product is covered by one or more of the following patents:

US B1 4,858,704; 4,953,638; 5,148,880; 5,242,026; 5,341,887; 5,490,569; 5,684,466;
5,713,423; 5,740,703; 5,758,553; 5,794,719; 5,880,680; 5,941,322; 6,085,852C1; 6,109,371;
6,179,065; 6,216,803; 6,250,403; 6,250,404; 6,290,606; 6,311,790; 6,411,094; 6,543,551;
6,550,547; 6,672,409; 6,739,413; 6,761,231; 6,776,246; 6,808,210; 6,827,158; 6,848,506;
6,871,712; 6,896,077; 7,000,710; 7,011,166; 7,013,990; 7,018,164; 7,025,152; 7,038,454;
7,111,693; 7,150,331; RE37,450; RE37,923; RE37,975; RE38,418

AU 689,533; 706,544; 718,034, 755,862

CA 2,156,398

FR 674,093

DE 694 17 019; 695 29 634; 697 28 716;

EP 0683845; 0674093; 0817901; 0846841

GB 2,312,006; 2,418,553; EP674,093; EP846,841

JP 3,458,247

Other U.S. and foreign patents pending

This manual contains information concerning the following models:
JT1220 Mach 1 Directional Drilling System

Copyright 2004, 2005, 2006, 2007, 2009, 2011 by The Charles Machine Works, Inc.

 **Ditch Witch**, Ditch Witch, CMW, AutoCrowd, Jet Trac, Roto Witch, Subsite, Fluid Miser, Power Pipe, Super Witch, Pierce Arrow, The Underground, The Underground Authority Worldwide, and Zahn are registered trademarks of The Charles Machine Works, Inc.

ID0135282

FOREWORD

This manual contains illustrated parts lists to help you select quality ProTech[®] Replacement parts for your Ditch Witch[®] equipment. Using other replacement parts will lessen the productivity of your equipment.

- ◆ Part numbers enclosed in a box are no longer available from The Charles Machine Works, Inc. Your local Ditch Witch dealer may be able to locate the part for you.
- ◆ Footnotes provide more information to help you identify parts shown in the manual.
- ◆ Assembly instructions and Tech Bits articles referenced in footnotes are available through your local Ditch Witch dealer.
- ◆ Description and specifications in this book were current at publication. However, The Charles Machine Works, Inc. reserves the right to improve equipment, so this manual might not reflect the most current improvements.
- ◆ Instructions on recommended equipment use and maintenance are in the Operator's Manual that was shipped with your equipment.

Keep the following in mind when ordering ProTech replacement parts:

- ◆ Specify parts you need by part number and description, not by illustration reference numbers.
- ◆ Have equipment model and serial number on hand to help ensure you get the right parts for your machine whether it's old or new.

Thank you for buying and using Ditch Witch equipment and ProTech replacement parts.

WARRANTY

DW WARRANTY Policy
July, 2005

POLICY 1: DITCH WITCH® EQUIPMENT AND REPLACEMENT PARTS LIMITED WARRANTY POLICY

Subject to the limitation and exclusions herein, free replacement parts will be provided at any authorized Ditch Witch dealership for any Ditch Witch equipment or parts manufactured by The Charles Machine Works, Inc. (CMW) that fail due to a defect in material or workmanship within one (1) year of first commercial use (Exception: 2 years for all SK500 Attachments). Free labor will be provided at any authorized Ditch Witch dealership for installation of parts under this warranty during the first year following "initial commercial" use of the serial numbered Ditch Witch equipment on which it is installed. The customer is responsible for transporting their equipment to an authorized Ditch Witch dealership for all warranty work.

EXCLUSIONS FROM PRODUCT WARRANTY

- All incidental or consequential damages.
- All defects, damages, or injuries caused by misuse, abuse, improper installation, alteration, neglect, or uses other than those for which products were intended.
- All defects, damages, or injuries caused by improper training, operation, or servicing of products in a manner inconsistent with manufacturer's recommendations.
- All engines and engine accessories (these are covered by original manufacturer's warranty).
- Tires, belts, and other parts which are subject to another manufacturer's warranty. (Such warranty will be available to purchaser.)
- ALL IMPLIED WARRANTIES NOT EXPRESSLY STATED HEREIN, INCLUDING ANY WARRANTY OF FITNESS FOR A PARTICULAR PURPOSE AND MERCHANTABILITY.

IF THE PRODUCTS ARE PURCHASED FOR COMMERCIAL PURPOSES, AS DEFINED BY THE UNIFORM COMMERCIAL CODE, THEN THERE ARE NO WARRANTIES WHICH EXTEND BEYOND THE FACE HEREOF AND THERE ARE NO IMPLIED WARRANTIES OF ANY KIND WHICH EXTEND TO A COMMERCIAL BUYER. ALL OTHER PROVISIONS OF THIS LIMITED WARRANTY APPLY INCLUDING THE DUTIES IMPOSED.

Ditch Witch products have been tested to deliver acceptable performance in most conditions. This does not imply they will deliver acceptable performance in all conditions. Therefore, to assure suitability, products should be operated under anticipated working conditions prior to purchase.

Defects will be determined by an inspection within thirty (30) days of the date of failure of the product or part by CMW or its authorized dealer. CMW will provide the location of its inspection facilities or it's nearest authorized dealer upon inquiry. CMW reserves the right to supply remanufactured replacement parts under this warranty as it deems appropriate.

Extended warranties are available upon request from your local Ditch Witch dealer or CMW.

Some states do not allow exclusion or limitation of incidental or consequential damages, so the above limitation or exclusion may not apply. Further, some states do not allow exclusion of or limitation of how long an implied warranty lasts, so the above limitation may not apply. This limited warranty gives product owner specific legal rights and the product owner may also have other rights which vary from state to state.

For information regarding this limited warranty, contact CMW's Product Support Department, P.O. Box 66, Perry, OK 73077-0066, or contact your local Ditch Witch dealer.

CONTENTS

Decals

Decal Location - JT1220 Mach 1	8
Decal Location - Pipe Box Loader	12

Engine Components

Air Filter System	22
Battery	42
Component Mounting	40
Controls - Rear	38
Engine - Cummins	16
Engine - Service - Cummins B3.3	20
Engine Skid	26
Hood Support - Front	28
Hoods - Front	32
Hoods - Rear	34
Radiator	24
Rear Hood Support & Grille	30
Sound Insulation - Engine Cover	36

Frame Components

Assisted Makeup Sensor	46
Carriage Spindle	50
Carriage	48
Frame Tilt	78
Fuel Tank	66
Gearbox - Ground Drive	70
Gearbox - Rotation Planetary	52
Grease Cylinder	74
Ground Drive Track - Rubber	68
Idler, Front	72
Pipe Guide	56
Proximity Switches - Drill Frame	80
Proximity Switches - Drill Pipe	82
Stabilizer	76
Thrust Drive	54
Wrench - Rotating - Begins	60
Wrench - Rotating	58
Wrench - Stationary - Begins	64
Wrench - Stationary	62

Operator's Station

Elect Strike System	96
Ground Drive Control	98
Left Console & Displays	90
Operator Floor	88
Operator Seat	86
Right Console & Joystick	94
Vandal Cover	92

Hydraulics

Anchor Hydraulics	118
Auxiliary Hydraulics	122
Cylinder (2"x1")	144
Cylinder (3.5"x1.75")	148
Cylinder (3.5"x1.75"x2")	150
Cylinder (3"x1.5")	146

Drilling Fluid Motor Hydraulic	124
Filter & Reservoir Hydraulics	102
Frame Tilt Hydraulics	138
Ground Drive Hydraulics	116
Hydraulic Valve Parts	142
Lubricator Hydraulics	120
Oil Cooler Hydraulics	104
P.O.R. Hydraulics	114
Pipe Box Shift Hydraulics	136
Pipe Grip/Selector Hydraulic	130
Pipe Lift Hydraulics	134
Pump/Selector Hydraulics	108
Rotating Wrench Hydraulic	126
Rotation Hydraulics	106
Selector Hydraulics	110
Shuttle Hydraulics	132
Stabilizer Hydraulics	140
Stationary Wrench Hydraulic	128
Thrust Hydraulics	112

Anchor Systems

Anchor System - Begins	156
Anchor System - Ends	154
Anchor Valve / Lubricator Mount	158
Auto-Lubricator	166
Grease Pump	160
Lubricator Nozzle & Applicator	164
Lubricator Valve	162

Fluid System

Drilling Fluid Plumbing	174
Drilling Fluid Pump Plumbing	172
Drilling Fluid Pump	170
Drilling Fluid Transfer	176

Pipe Loader Systems

Lifters - Ends	184
Lifters	182
Pipe Box	194
Pipe Loader Valve / Covers	192
Pivot Arm	180
Shuttle Guard	190
Shuttle Mount	188
Shuttle	186

Electrical

*See technical supplement for further electrical information	#053-116
--	----------

CONTINUED

CONTENTS

Accessories

Antifreeze Tank	202
Canopy	208
Cold Start Kit	200
FM5 on T18B.....	214
Heated Greaser.....	206
Pipe Box Loader	216
Softcab	210
T18B Tie Down Kit	212
Transport Pipe Box.....	218
Umbrella	204

Miscellaneous

Bolt/Nut Torque Chart	222
Filters	226
Optional Kits	226
Parts Manual Change Request	227
Related Publications	226
Replacement O-Ring Chart.....	225
Warranty Registration	230

DECALS

DECAL LOCATION JT1220 MACH 1

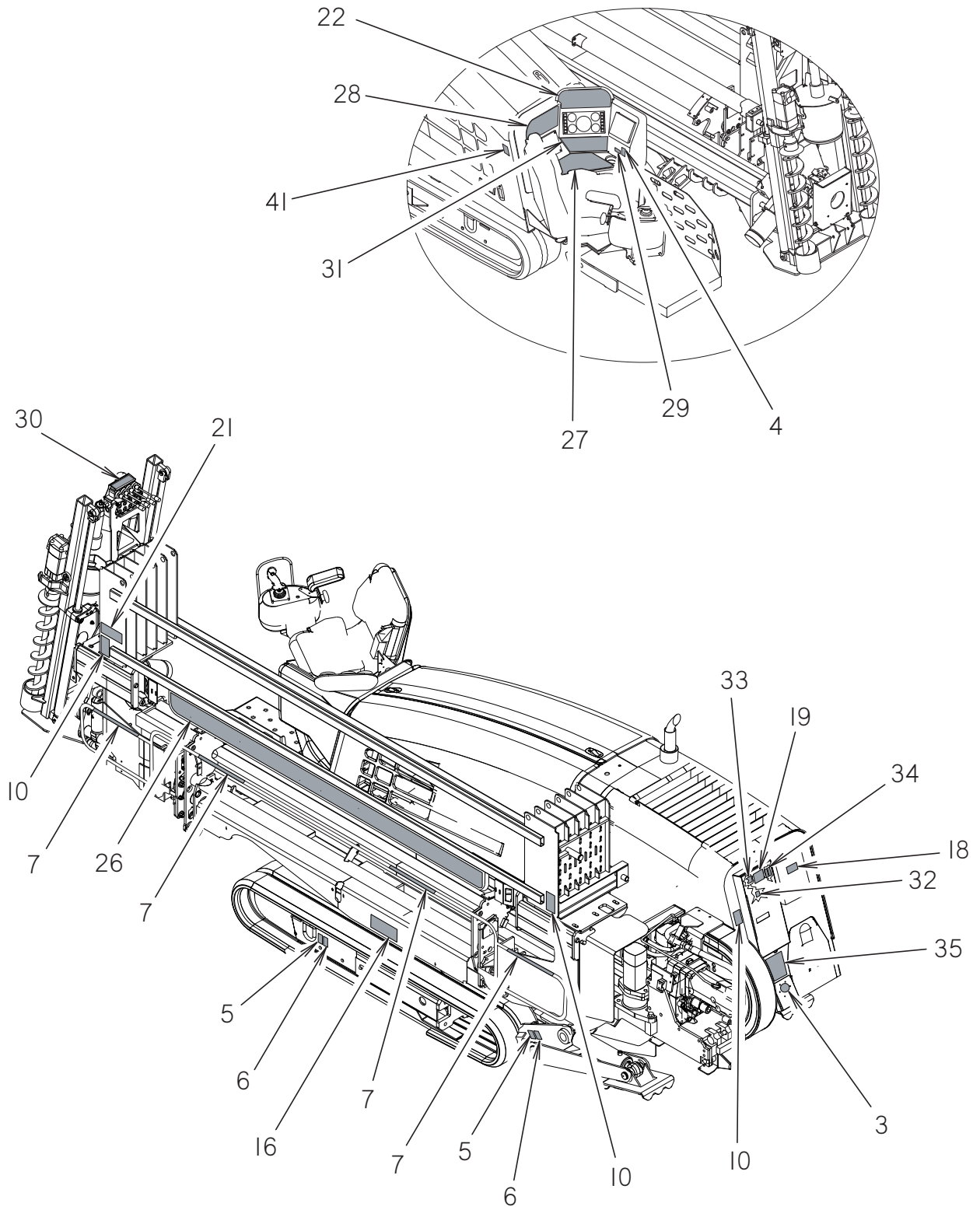

DECAL LOCATION JT1220 MACH 1

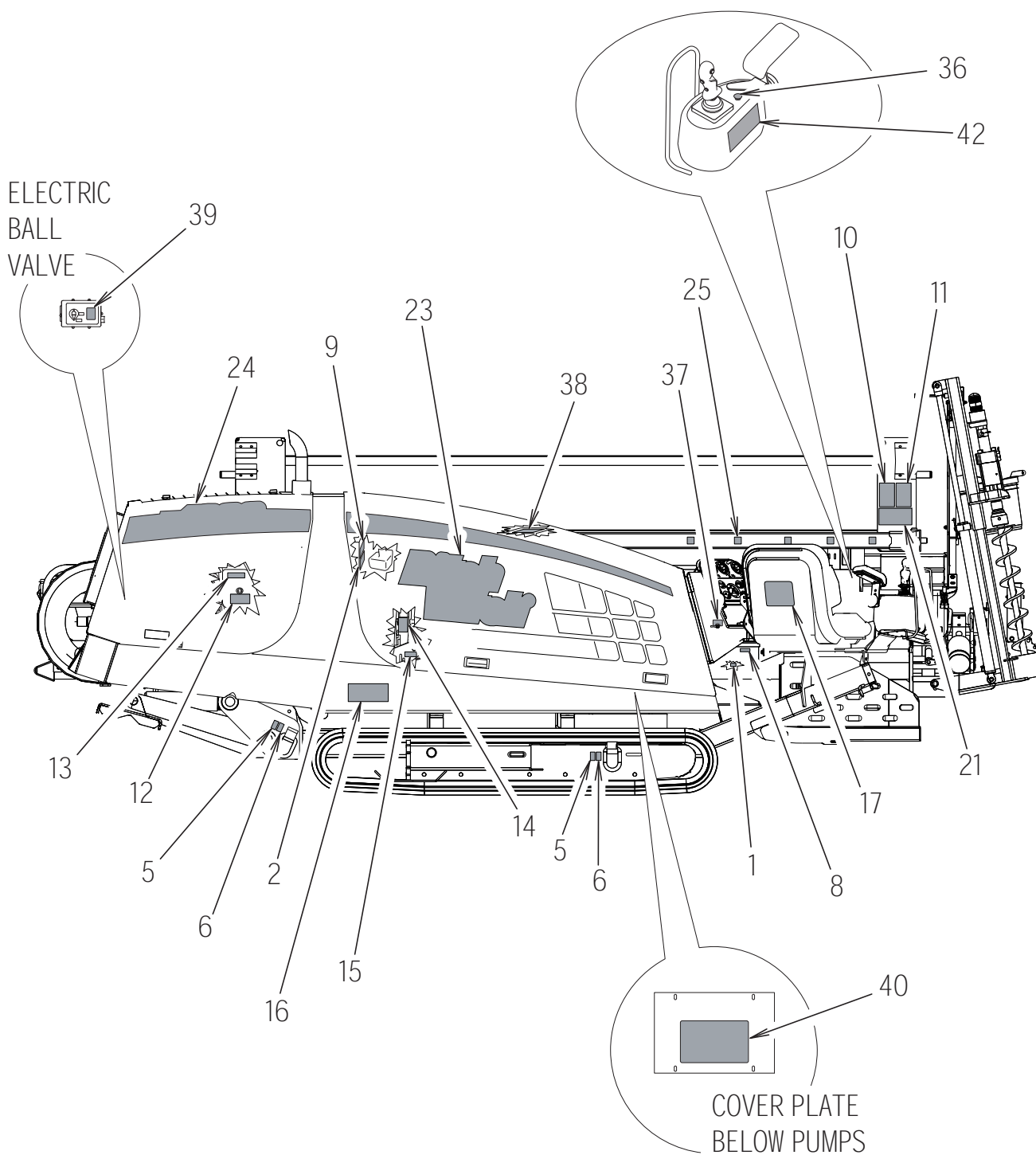

DECAL LOCATION JT1220 MACH 1

REF NO.	PART NUMBER	QTY	DESCRIPTION	REMARKS
	275-908		DECAL KIT - JT1220	
I	273-267	1	DITCH WITCH BATTERY	
2	273-146	1	NOTICE ADD COOLANT	
3	700-062	1	DIESEL FUEL CAP	
4	274-724	1	ONE CALL NOTIFICATION	
5	274-442	4	LIFT LOCATION	
6	274-318	4	TIE DOWN LOCATION	
7	275-230	4	DANGER STRIPE 1.75" x 18"	
8	275-203	1	BATTERY	
9	273-138	1	NOTICE COOLANT	
10	275-184	4	WARNING MOVING PARTS	
II	273-278	1	DANGER WRENCH	
12	274-198	1	NOTICE OIL LEVEL	
13	275-120	1	RESERVOIR (THF)	
14	275-355	1	CAUTION HOT PARTS	
15	275-400	1	NOTICE OIL LEVEL	
16	274-049	2	DANGER ELECTROCUTION	
17	274-854	1	LOGO PLACARD	
18	275-048	1	IMPORTANT SAFETY RULES	
19	275-449	1	DITCH WITCH LOGO PLACARD	
20	274-291	1	SOUND POWER IO	SEE FOOT NOTE I
21	275-197	2	DANGER ROTATING SHAFT	
22	273-407	1	GAUGE PANEL	
23	273-434	1	DITCH WITCH	
24	273-435	1	JT1220 W/ STRIPE	
25	273-444	1	PIPE BOX NUMBERS	
26	273-445	1	PIPE BOX STRIPE/MODEL ID	
27	700-067	1	CONTROL PANEL	
28	700-068	1	SWITCH PANEL	
29	700-069	1	IGNITION PANEL	
30	700-071	1	STAKE DRIVER	
31	700-092	1	SWITCH PANEL	
32	273-198	1	TRACKER CONTROL	
33	273-482	1	IGNITION SWITCH	
34	700-146	1	TRACK SWITCH	
35	700-147	1	FRAME TILT	
36	273-601	1	ENGINE STOP	
37	700-191	1	MASTER DISCONNECT SWITCH	
38	273-523	1	RELAYS	
39	273-567	1	NOTICE NOT MANUAL SHUTOFF	
40	273-569	1	JT1220 TEST PORT LOCATIONS	
41	274-780	1	JET TRAC PATENT (S)	
42	700-245	1	RIGHT CONTROL	

FOOTNOTES

1. NOT PART OF KIT.

PIPE BOX LOADER DECAL LOCATION

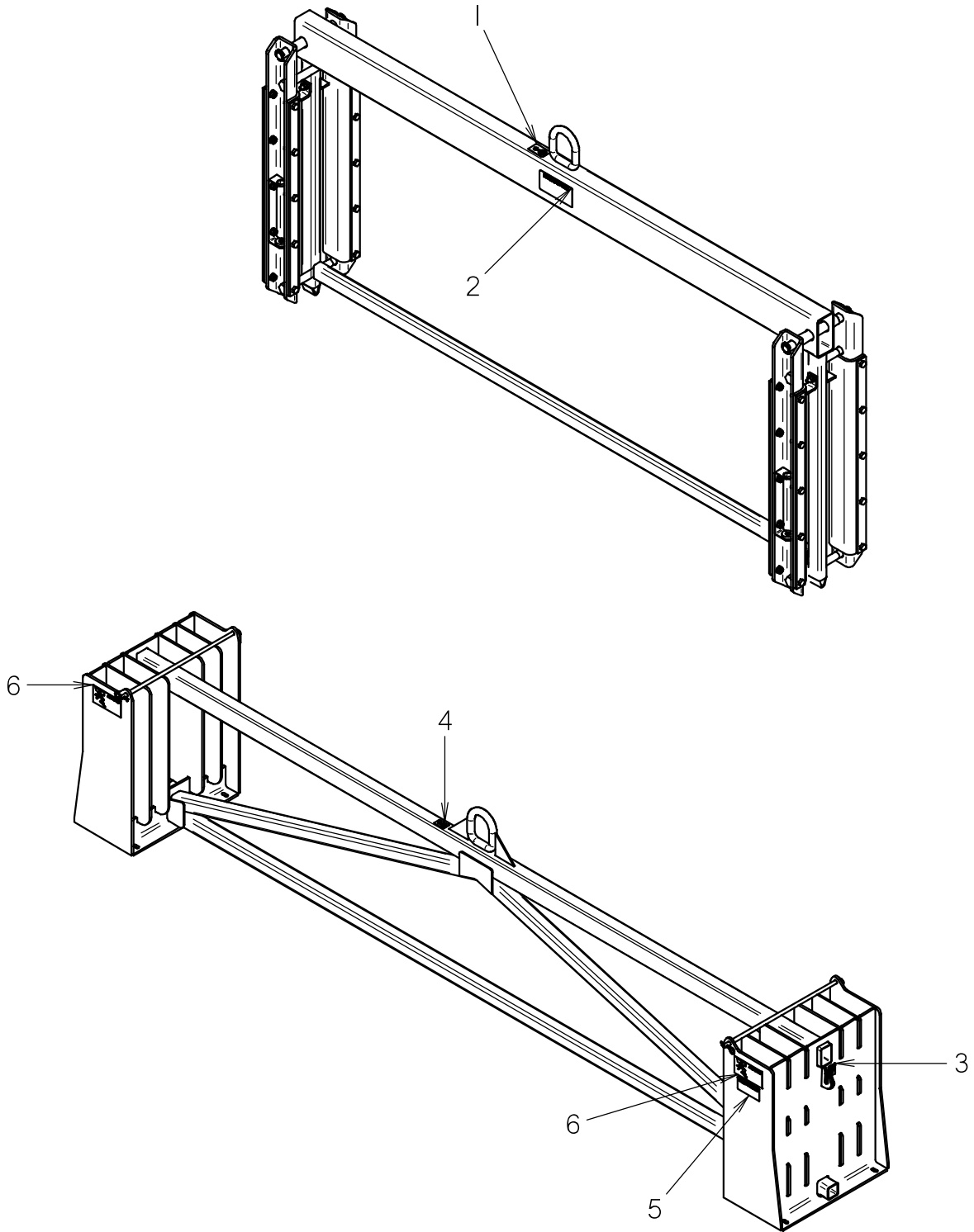

PIPE BOX LOADER DECAL LOCATION

REF NO.	PART NUMBER	QTY	DESCRIPTION	REMARKS
1	274-442	1	LIFT LOCATION	
2	270-1018	1	PIPE BOX LOADER WEIGHT	
3	274-318	2	TIE DOWN LOCATION	OPPOSITE ENDS
4	274-442	1	LIFT LOCATION	
5	273-642	2	TRANSPORT BOX WEIGHT	JT2020 ONLY. 270-1016 USED ON JT1220, OPPOSITE CORNERS
6	275-326	4	WARNING, CRUSHING WEIGHT	OPPOSITE SIDES

NOT SHOWN:

FOOTNOTES:

NOTE:

ENGINE COMPONENTS

ENGINE

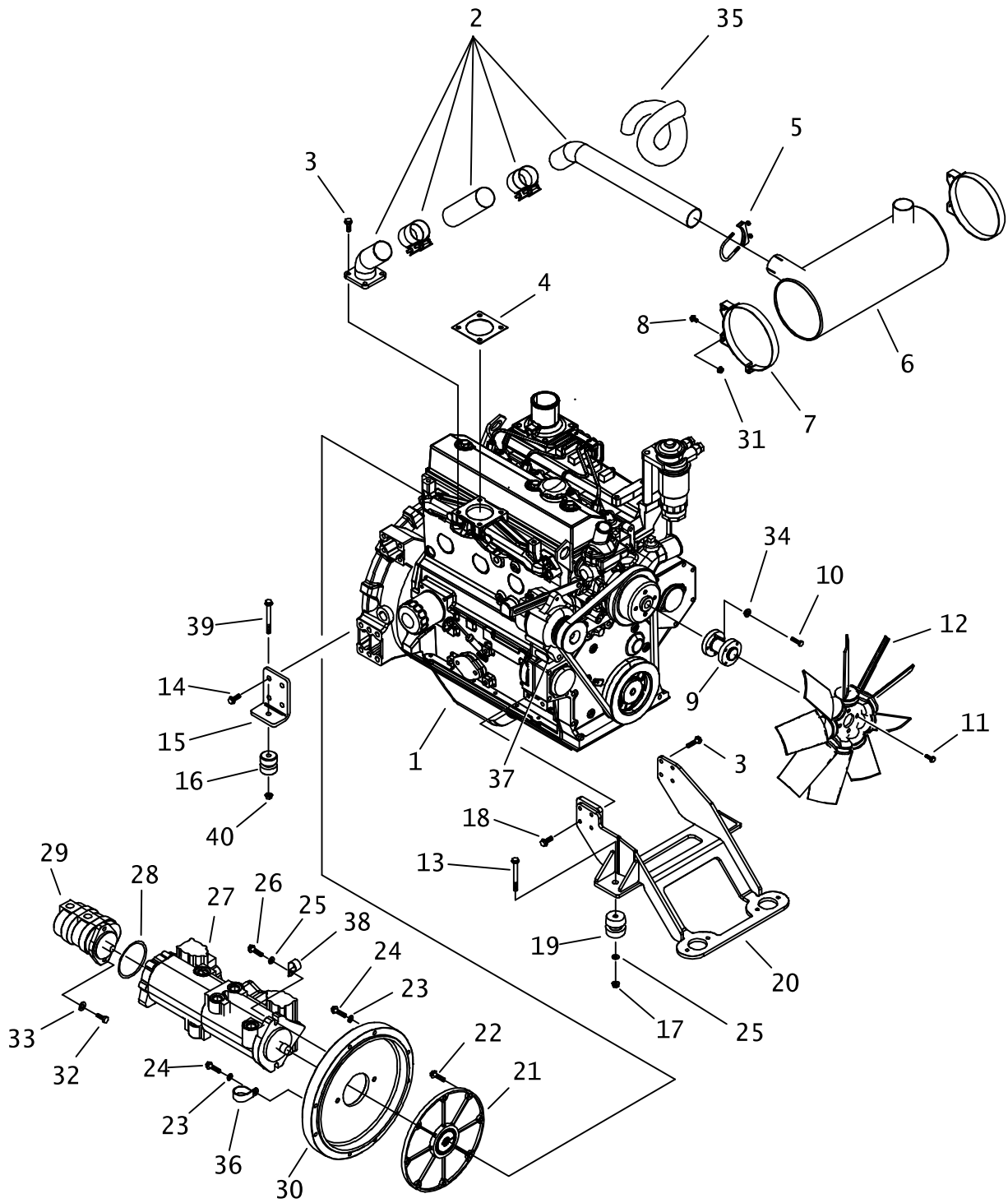

ENGINE

REF NO.	PART NUMBER	QTY	DESCRIPTION	REMARKS
1.	194-481	1	ENGINE - CUMMINS 60HP TIER II	OBSOLETE
2.	194-277	1	EXHAUST KIT	TORQUE CLAMPS TO 45-60 FT-LBS
3.	106-724	8	FL SCREW (M10-1.50 X 25MM)	TORQUE TO 30 FT-LBS
4.	194-446	1	EXHAUST GASKET	
5.	318-485	1	MUFFLER CLAMP	
6.	194-231	1	MUFFLER	
7.	323-618	2	MUFFLER BRACKET	
8.	105-822	4	FLANGE LOCK BOLT (5/16-NC X ")	
9.	178-922	1	FAN SPACER	
10.	106-267	4	SCREW (M8-1.25 X 35MM)	TORQUE TO 20 FT-LBS
11.	106-381	4	FL LK SCREW (M8-1.25 X 25MM)	TORQUE TO 20 FT-LBS
12.	194-821	1	COOLING FAN	
13.	106-700	2	SCREW (M12-1.75 X 80MM)	
14.	106-469	8	FL SCREW (M12-1.75 X 30MM)	TORQUE TO 55 FT-LBS
15.	314-764	2	REAR ENGINE MOUNT	
16.	116-217	2	SHOCK MOUNT (2-PIECE KIT)	
17.	106-685	2	LCKNUT (M12-1.75, PRV TRQ, 10.9)	
18.	105-271	4	SCREW (M10-1.5 X 40MM)	TORQUE TO 30 FT-LBS
19.	117-559	2	ISOLATOR	
20.	314-758	1	FRONT ENGINE MOUNT	
21.	194-704	1	FLYWHEEL COUPLING	TORQUE SET SCREW TO 50 FT-LBS
22.	106-383	8	FLG LK SCREW (M10-1.50 X 30MM)	TORQUE TO 33 FT-LBS LOCTITE RC271
23.	105-073	9	LOCK WASHER (7/16")	
24.	105-839	9	SCREW (M10-1.50 X 55MM)	TORQUE TO 30 FT-LBS
25.	106-397	6	WASHER (M12, HARDENED)	
26.	105-062	2	FLG BOLT (1/2-NC X 1-1/2", FER)	
27.	157-239	1	DUAL HYDROSTAT	
	190-805	-	SEAL REPAIR KIT	
	217-258	-	ELECTRIC DISPLACEMENT CONTROL	
	150-1017	-	HYD RELIEF VALVE	
	150-1018	-	HYD RELIEF VALVE	
	150-1019	-	HYD RELIEF VALVE	
	150-1020	-	SPRING, RELIEF	
	190-1015	-	SHIM KIT	
	152-173	-	HYD RELIEF VALVE	
	152-174	-	HYD RELIEF VALVE	
	157-568	-	SHAFT SEAL	
	499-448	-	SERVO COVER	WITH NEUTRAL ADJUSTMENT
	499-447	-	SERVO COVER (FULL DISPL)	WITHOUT NEUTRAL ADJUSTMENT

FOOTNOTES:

NOTE:

1. REFER TO O-RING CHART 800-301 FOR REPLACEMENT O-RING

ENGINE

REF NO.	PART NUMBER	QTY	DESCRIPTION	REMARKS
28.	157-041	1	O-RING (152 D70)	
29.	157-860	1	DOUBLE GEAR PUMP	
30.	194-763	1	MOUNT PLATE	
31.	105-003	4	FLG LOCKNUT (5/16-NC)	
32.	105-052	2	BOLT (3/8-NC X 1-1/4")	
33.	105-117	2	WASHER (5/16")	
34.	105-091	4	LOCK WASHER (5/16")	
35.	115-834	AR	EXHAUST WRAP (2", SOLD PER FT)	USE 1 @ 30'
36.	110-332	1	BOLT-ON CLAMP (1-5/8")	
37.	214-256	1	DIODE CONNECTOR	
38.	110-333	1	BOLT-ON CLAMP (1")	
39.	106-810	2	SCREW (M16-2.00 X 90MM, 10.9)	
40.	106-545	2	LOCKNUT (M16-2.0, PRV TRQ, 10.9)	

FOOTNOTES:

NOTE:

1. REFER TO O-RING CHART 800-301 FOR REPLACEMENT O-RING

CUMMINS B3.3 ENGINE SERVICE

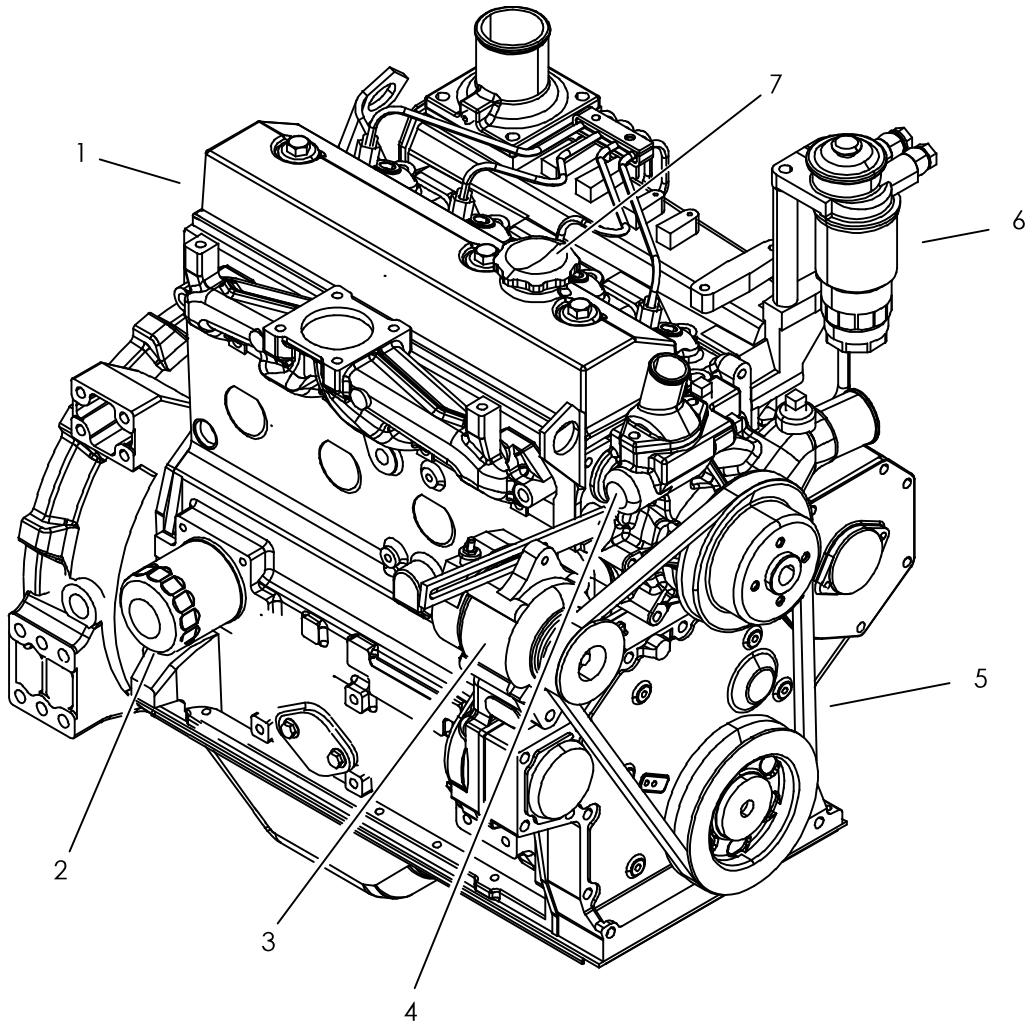

CUMMINS B3.3 ENGINE SERVICE

REF NO.	PART NUMBER	QTY	DESCRIPTION	REMARKS
1.	194-481	1	ENGINE - CUMMINS 60HP TIER 2	OBSOLETE
2.	194-454	1	ENGINE OIL FILTER	
3.	194-462	1	ALTERNATOR 12V/60A (B3.3)	
4.	194-459	1	WATER PUMP (CUMMINS B3.3)	
5.	170-397	1	BELT	
6.	194-461	1	FUEL FILTER ELEMENT (B3.3)	
7.	499-598	1	OIL FILL CAP (VALVE COVER)	

NOT SHOWN

053-103	1	CUMMINS B3.3 PARTS MANUAL
055-069	1	CUMMINS B3.3 OPERATION MANUAL
055-070	1	CUMMINS B3.3 REPAIR MANUAL
194-458	1	STARTING MOTOR 12V (B3.3)
499-602	1	THERMOSTAT (B3.3)
157-945	1	THERMOSTAT GASKET
157-944	1	WATER PUMP GASKET (B3.3)
499-603	1	ENGINE KILL SOLENOID
499-599	1	ENGINE OIL DIP STICK (B3.3)
194-696	1	INTAKE MANIFOLD
500-2084	1	FLUID LEVEL SENSOR

FOOTNOTES:

NOTE:

AIR FILTER SYSTEM

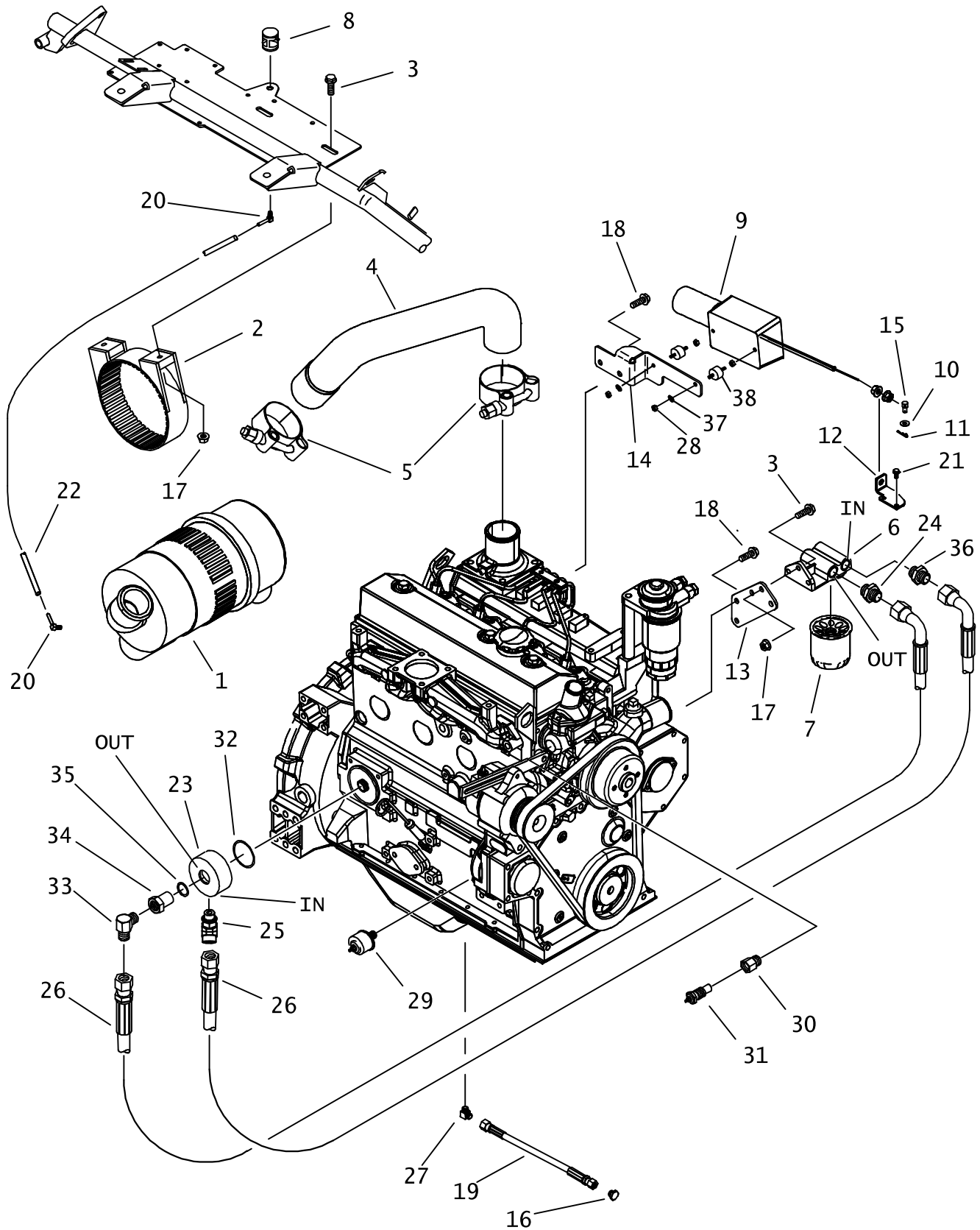

AIR FILTER SYSTEM

REF NO.	PART NUMBER	QTY	DESCRIPTION	REMARKS
1.	194-297	1	AIR FILTER	
	194-758	-	ELEMENT (SAFETY)	
	194-759	-	ELEMENT (PRIMARY)	
	194-760	-	COVER	
	194-761	-	DISCHARGE VALVE	
2.	149-165	1	MOUNTING CLAMP	
3.	106-381	5	FLG LK SCREW (M8-1.25 X 25MM)	
4.	117-851	1	AIR INTAKE HOSE	
5.	157-908	2	T-BOLT CLAMP (2.812-3.187)	
6.	194-514	1	REMOTE FILTER HEAD	
7.	194-454	-	OIL FILTER	
8.	194-788	1	RESTRICTION INDICATOR (25"H2O)	
9.	213-116	1	LINEAR ACTUATOR	SEE FOOTNOTE I.
10.	105-284	1	WASHER (3/16")	
11.	105-530	1	COTTER PIN (1/16 X 3/4 ")	
12.	315-573	1	THROTTLE BRACKET	
13.	318-542	1	MOUNT PLATE	
14.	300-5765	1	MOUNT BRACKET	
15.	105-603	-	CABLE PIVOT	
16.	154-331	1	PLUG (Ø80)	
17.	106-386	5	FLG LK NUT (M8-1.25)	
18.	106-382	4	FLG LK SCREW (M10-1.50 X 20 MM)	
19.	154-711	1	HOSE (Ø80FX-30-3000)	
20.	155-241	2	S/O COUPLER (Ø2N-Ø5H90)	
21.	106-224	2	FLG SCREW (M6-1.00 X 10MM)	
22.	116-108	AR	BULK HOSE (5/16", SOLD PER 1")	USE 1 @ 16"
23.	158-108	1	FILTER MOUNT FLANGE	
24.	157-756	1	CONNECTOR (Ø8N-100)	
25.	154-313	1	CONNECTOR (Ø8S-10045)	
26.	515-720	2	HOSE (100FX90S-32"-3000)	
27.	157-445	1	BANJO FITTING (M22-1.5)	
28.	105-078	4	NUT (1/4-NC)	
29.	215-183	1	SENDER, OIL PRESSURE HD	
30.	217-247	1	WATER TEMPERATURE ADAPTER	
31.	217-565	1	TEMPERATURE SENDER 100 - 280 F	
32.	157-020	1	O-RING (120 D90)	
33.	154-323	1	CONNECTOR (Ø8S-10090)	
34.	158-109	1	FILTER MOUNT BOLT	
35.	158-110	1	O-RING (230 D90)	
36.	150-2080	1	EXTENTION FITTING (Ø8N-100)	
37.	150-079	2	LOCK WASHER (1/4)	
38.	300-5701	2	MOUNT, RUBBER STOCK	

FOOTNOTES:

I. 196-366 CABLE (LINEAR ACTUATOR)

NOTE:

RADIATOR

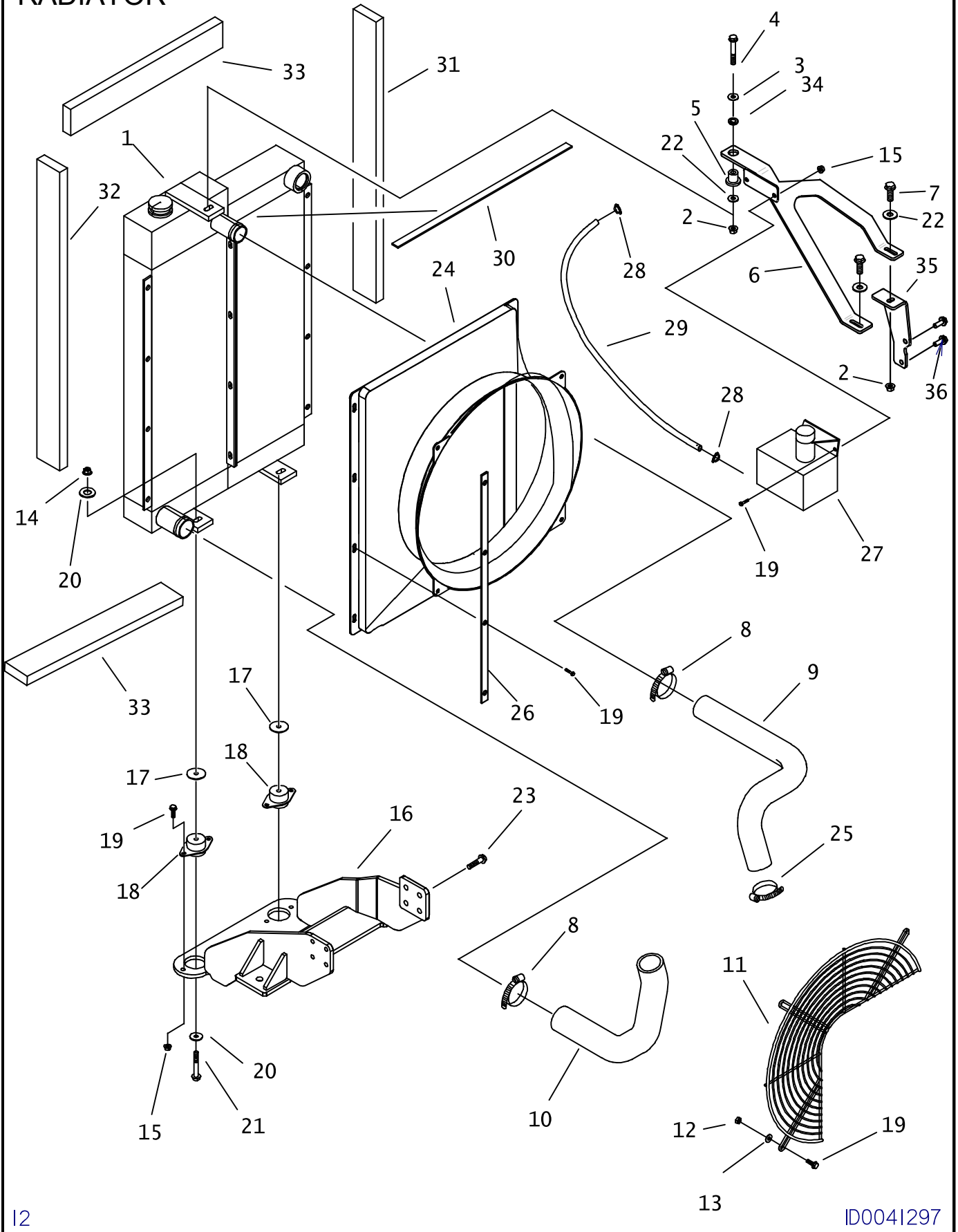

RADIATOR

REF NO.	PART NUMBER	QTY	DESCRIPTION	REMARKS
1.	194-229	1	RADIATOR/OIL COOLER	
	500-1325	1	RADIATOR CAP (7PSI)	
2.	106-387	2	FLG LOCKNUT (M10-1.50)	
3.	105-059	1	WASHER (7/16")	
4.	106-142	1	SCREW (M10-1.50 X 65MM)	
5.	116-727	1	SHOCK MOUNT	
6.	325-943	1	RADIATOR BRACKET	
7.	106-383	2	FLG LK SCREW (M10-1.50 X 30MM)	USE LOCTITE 242 OR EQUIVALENT
8.	110-134	3	WORM CLAMP (2.062" TO 2.750")	
9.	117-553	1	UPPER RADIATOR HOSE	
10.	117-554	1	LOWER RADIATOR HOSE	
11.	310-613	1	FAN GUARD	
12.	107-096	4	LOCKNUT (M8-1.25 , NYLOK)	
13.	106-389	3	WASHER (M8)	
14.	105-894	2	LOCKNUT(M10-1.50,PRV TRQ,10.9)	
15.	106-386	6	FLG LOCKNUT (M8-1.25)	
16.	314-758	-	FRONT ENGINE MOUNT	
17.	105-071	2	WASHER (1/2")	
18.	116-539	2	ISOLATOR	
19.	106-381	17	FLG LK SCREW (M8-1.25 X 25MM)	
20.	106-396	4	WASHER (M10, HARDENED)	
21.	106-332	2	SCREW (M10-1.50 X 70MM)	
22.	106-397	2	WASHER (M12, HARDENED)	
23.	105-274	8	BOLT (M10-1.5 X 20MM)	
24.	362-970	1	FAN SHROUD	
25.	110-133	1	WORM CLAMP(1-1/16"TO 1-15/16")	
26.	300-4721	2	SHROUD BAR	
27.	364-432	1	COOLANT OVERFLOW RESERVOIR	
28.	110-249	2	WORM CLAMP (1/4: TO 5/8")	
29.	116-108	AR	BULK HOSE (5/16", SOLD PER 1")	USE 1 @ 11"
30.	115-380	AR	BULK STRIP (3/4", SOLD PER 1")	USE 2 @ 20"
31.	118-166	1	SOUND INSULATION	
32.	118-168	1	SOUND INSULATION	
33.	118-167	2	SOUND INSULATION	
34.	105-363	1	WASHER (7/8")	
35.	325-945	1	BRACKET	
36.	105-799	2	FLG LK SCREW (M10-1.50 X 25MM)	

NOT SHOWN:

FOOTNOTES:

NOTE:

ENGINE SKID

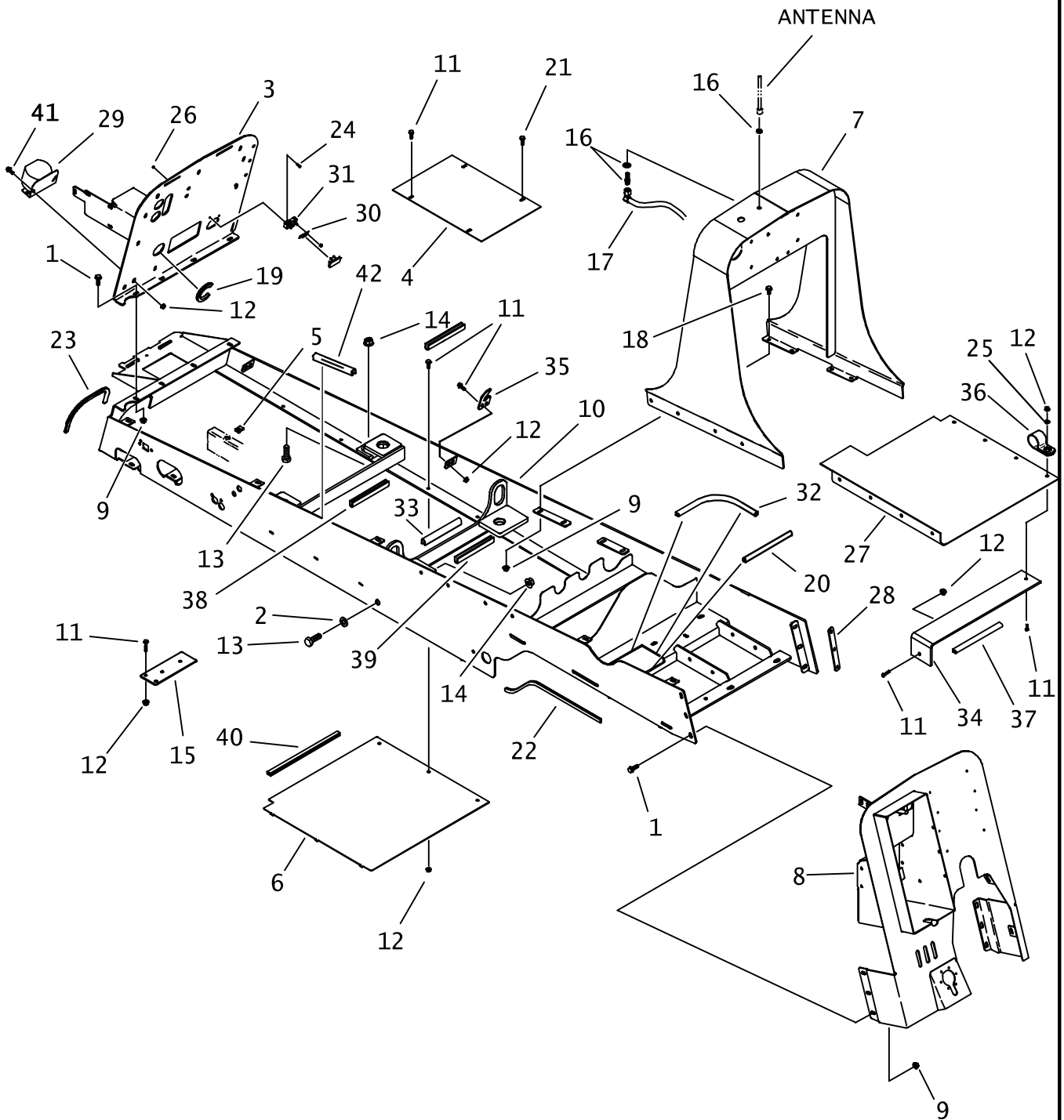

ENGINE SKID

REF NO.	PART NUMBER	QTY	DESCRIPTION	REMARKS
1.	106-724	10	FLG LK SCREW (M10-1.50 X 25MM)	
2.	106-398	4	WASHER (M16 HARDENED)	
3.	318-998	1	FRONT MOUNT	
4.	320-405	1	COVER PLATE	
5.	106-551	2	CLIP NUT (M8-1.25)	
6.	318-762	1	FLOOR PLATE	
7.	315-414	1	CENTER MOUNT WELDMENT	
8.	318-656	1	BACK PLATE WELDMENT	
9.	106-387	18	FLG LKNUT (M10-1.50)	
10.	315-422	1	ENGINE SKID	
11.	106-162	24	FLG SCREW (M8-1.25 X 20 MM)	
12.	106-386	24	FLG LKNUT (M8-1.25)	
13.	106-616	4	SCREW (M16-2.00 X 55MM, 10.9)	
14.	106-355	4	FLG LOCKNUT (M16-2.00)	
15.	318-763	2	BRACKET	
16.	211-055	1	ANTENNA BULKHEAD CONNECTOR	
17.	211-072	1	CABLE	
18.	106-382	8	FLG LK SCREW (M10-1.50 X 20MM)	
19.	115-686	AR	BULK EDGE (5/32", SOLD PER 1")	USE 1 @ 5"
20.	115-704	AR	BULK EDGE (1/4", SOLD PER 1")	USE 1 @ 9"
21.	106-381	1	FLG LK SCREW (M8-1.25 X 25MM)	
22.	115-704	AR	BULK EDGE (1/4", SOLD PER 1")	USE 1 @ 19"
23.	115-704	AR	BULK EDGE (1/4", SOLD PER 1")	USE 1 @ 12"
24.	106-367	2	SCREW (#6-32 X1/2")	
25.	105-117	7	WASHER (5/16")	
26.	105-215	2	NUT (#6-32)	
27.	323-680	1	BOTTOM COVER	
28.	318-985	1	SPACER	
29.	306-602	1	ALARM	
	214-103	1	(2-WAY) MALE CONNECTOR	
	214-104	2	PACKARD MALE TERMINAL	
	157-645	2	WEATHER-PAC SEAL (2.80MM)	
30.	211-305	1	BK/AMI 125 AMP FUSE	
31.	363-714	1	FB/HVAMI FUSE HOLDER	BEGINS WITH S/N:
	211-307	1	AMI FUSE COVER	
	105-215	2	NUT (#6-32)	
32.	115-704	AR	BULK EDGE (1/4", SOLD PER 1")	USE 1 @ 17"
33.	116-259	AR	BULK EDGE (1/2", SOLD PER FT)	USE 1 @ 12"
34.	325-188	1	BRACKET	
35.	318-984	2	LATCH CATCH	
36.	110-333	1	BOLT ON CLAMP (1")	
37.	115-704	AR	BULK EDGE (1/4", SOLD PER 1")	USE 1 @ 12"
38.	116-259	AR	BULK EDGE (1/2", SOLD PER FOOT)	USE 1 @ 11"
39.	116-259	AR	BULK EDGE (1/2", SOLD PER FOOT)	USE 1 @ 12"
40.	115-686	AR	BULK EDGE (5/32", SOLD PER 1")	USE 1 @ 12"
41.	106-380	2	FLG SCREW (M8-1.25 X 16 MM)	
42.	116-259	AR	BULK EDGE (1/2", SOLD PER FOOT)	USE 1 @ 4"

FOOTNOTES

31. 211-306 1 FB/HVAMI FUSE HOLDER ENDS WITH S/N:

NOTE:

FRONT HOOD SUPPORT

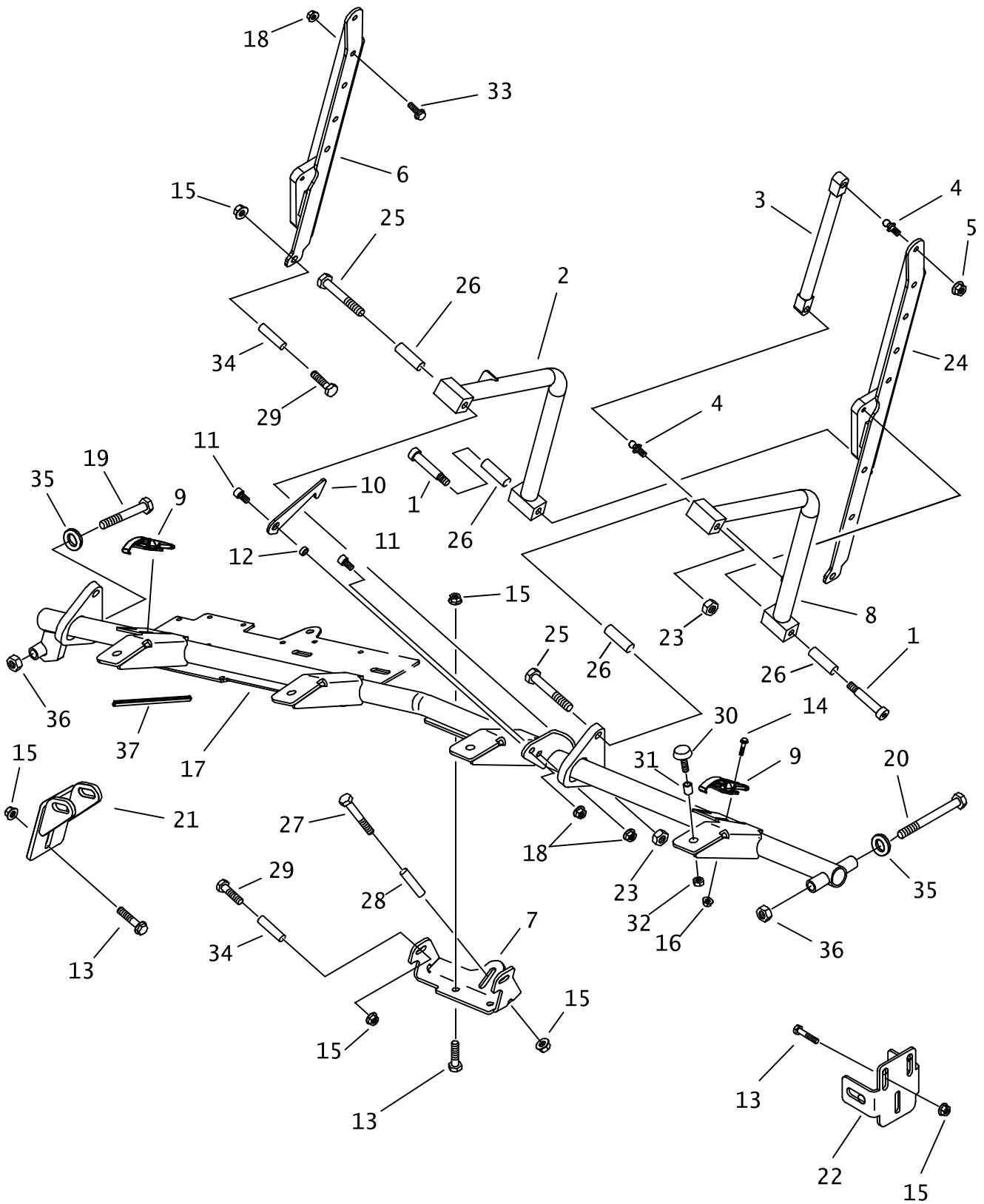

FRONT HOOD SUPPORT

REF NO.	PART NUMBER	QTY	DESCRIPTION	REMARKS
1.	106-971	4	SHLD BLT (M12 X 50MM, M10-1.50)	
2.	319-706	2	ARM	
3.	151-227	2	GAS STRUT	
4.	110-655	4	BALL SCREW (5/16-NC X 1/2")	
5.	105-089	2	LOCKNUT (5/16-NC)	
6.	319-708	1	HOOD SUPPORT	
7.	118-185	1	LATCH BRACKET	
8.	319-707	2	ARM	
9.	110-014	2	LATCH	
10.	117-932	1	HOOK	
11.	105-842	4	SCREW (M8-1.25 X 20MM, SOC)	
12.	179-593	1	BUSHING	
13.	106-724	7	FLG SCREW (M10-1.50 X 25MM)	
14.	105-185	4	BOLT (#10-24 X 1/2", RD SLT HD)	
15.	106-387	12	FLG LOCKNUT (M10-1.50)	
16.	106-048	4	LOCKNUT (#10-24)	
17.	319-529	1	SUPPORT	
18.	106-386	12	FLG LOCKNUT (M8-1.25)	
19.	106-578	1	SCREW (M12-1.75 X 80MM)	
20.	106-579	1	SCREW (M12-1.75 X 120MM)	
21.	319-531	1	FRONT BRACKET	
22.	319-178	1	BRACKET	
23.	106-031	4	LOCKNUT (M12-1.75, NLK)	
24.	318-486	1	REAR HOOD BRACKET	
25.	106-700	4	SCREW (M12-1.75 X 80MM)	
26.	179-832	8	SLEEVE	
27.	106-142	1	SCREW (M10-1.50 X 65MM)	
28.	179-877	1	BUSHING	
29.	105-271	4	SCREW (M10-1.5 X 40MM)	
30.	110-044	4	BUMPER (5/16-NC X 1-1/4")	
31.	106-038	4	NUTSERT (5/16-NC)	
32.	106-252	4	JAM NUT (5/16-NC)	
33.	106-381	10	FLG LK SCREW (M8-1.25 X 25MM)	
34.	178-151	4	BOSS	
35.	106-397	2	WASHER (M12, HARDENED)	
36.	106-709	2	FLG LK NUT (M12-1.75)	
37.	115-686	AR	BULK EDGE (5/32", SOLD PER 1")	USE 1 @ 4"

FOOTNOTES

NOTE:

REAR HOOD SUPPORT AND GRILLE

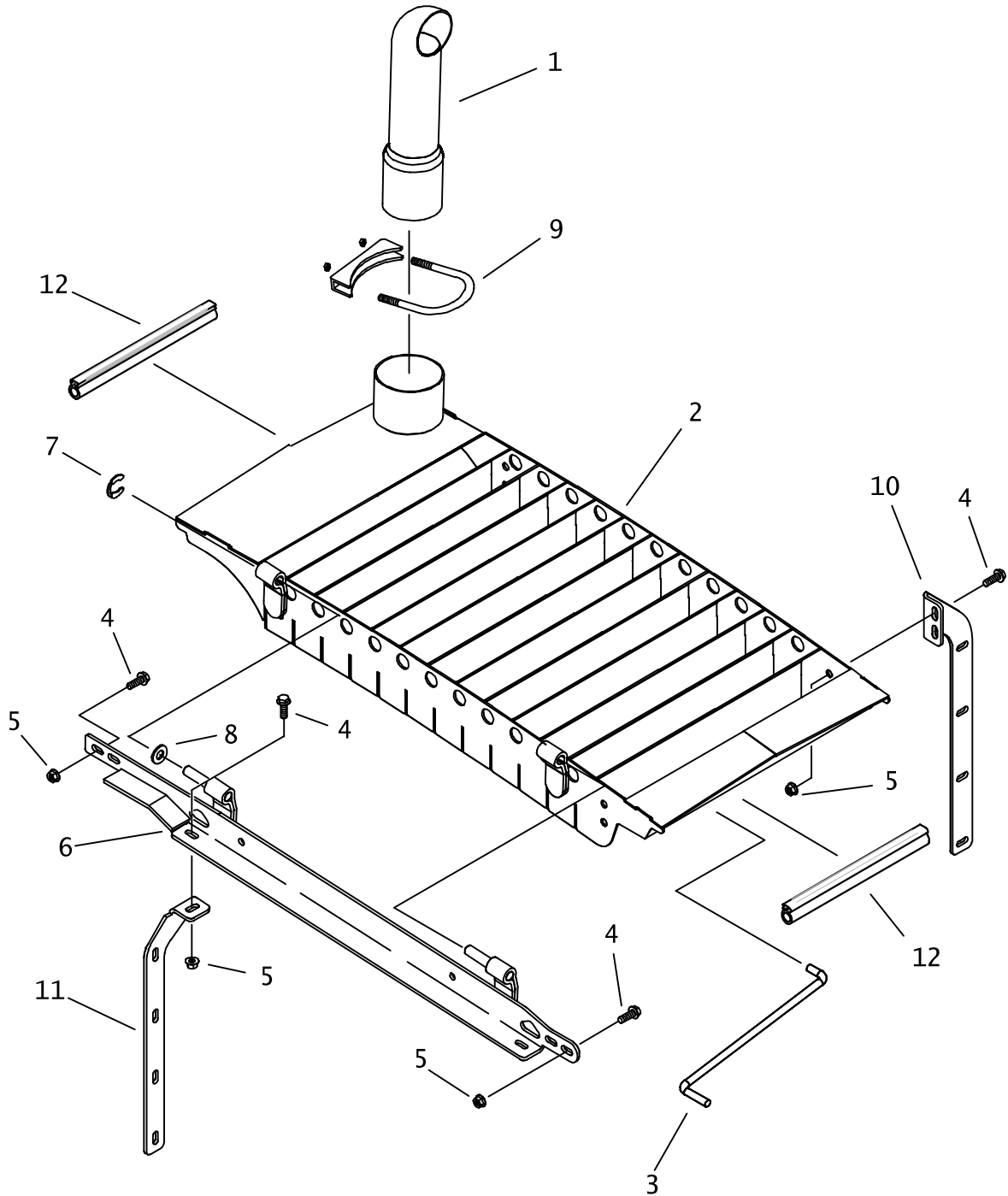

REAR HOOD SUPPORT AND GRILLE

REF NO.	PART NUMBER	QTY	DESCRIPTION	REMARKS
1.	194-266	1	EXHAUST PIPE	
2.	319-794	1	GRILLE	
3.	179-583	1	PROP ROD	
4.	106-162	10	FLG SCREW (M8-1.25 X 20MM)	
5.	106-386	10	FLG LOCKKNUT (M8-1.25)	
6.	319-801	1	REAR HOOD SUPPORT	
7.	115-482	2	GRIP RING (.500")	
8.	106-397	2	WASHER (M12, HARDENED)	
9.	195-993	1	U-BOLT CLAMP (3.50")	
10.	319-799	2	HOOD BRACE	
11.	319-804	2	PANEL SUPPORT	
12.	116-489	AR	EDGING (SOLD PER FT)	USE 2 @ 16"

NOT SHOWN:

FOOTNOTES:

NOTE:

FRONT HOOD ASSEMBLY

JT12M1 / JT20M1

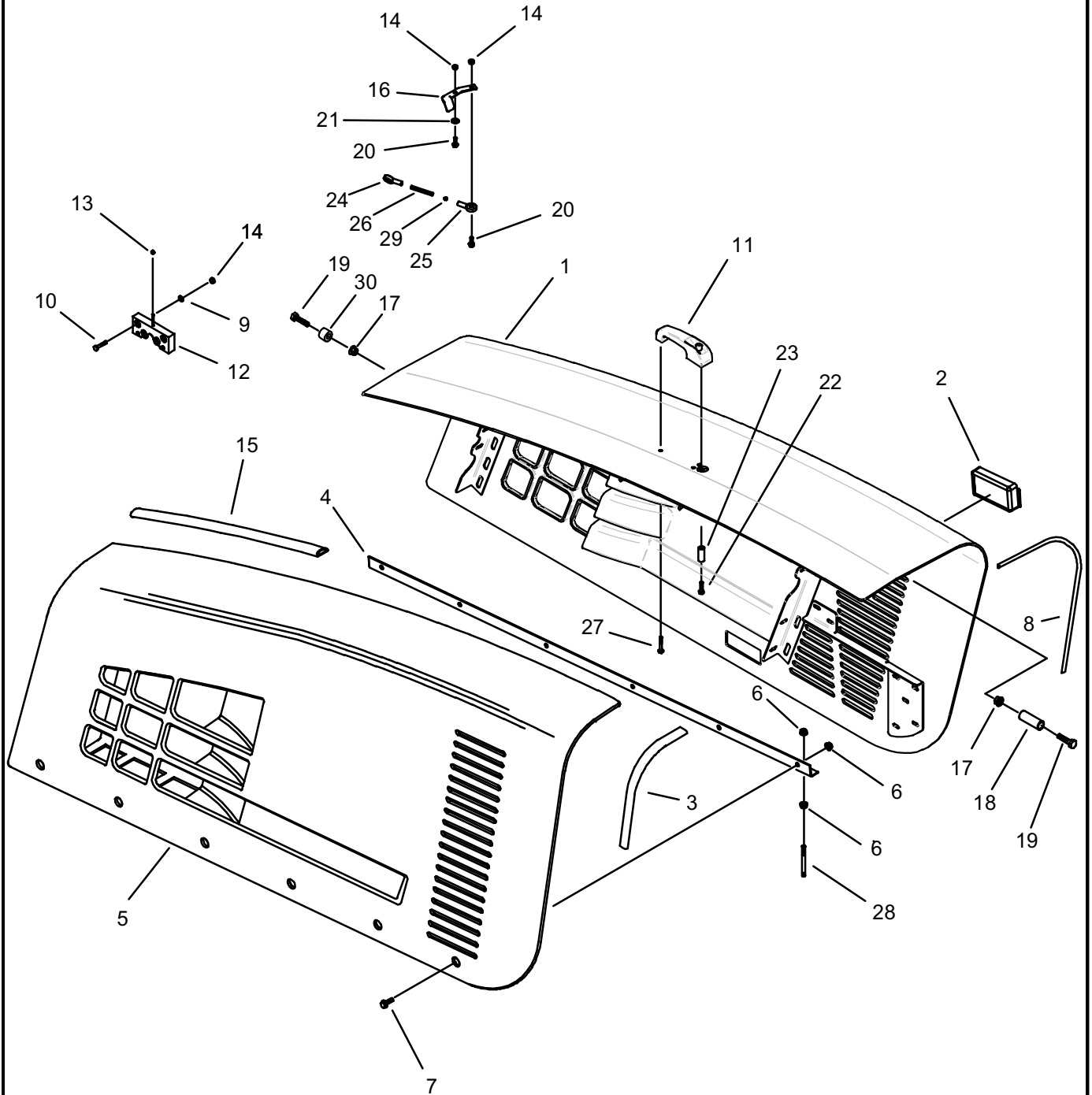

FRONT HOOD ASSEMBLY

JT12M1 / JT20M1

REF NO.	PART NUMBER	QTY	DESCRIPTION	REMARKS
1.	325-956	1	FRONT HOOD	SERVICE PART 191-503
2.	117-427	1	POCKET PULL	
3.	118-183	AR	BULK EDGE (SOLD BY FOOT)	USE 1 @ 125"
4.	319-393	1	BRACKET	
5.	325-955	1	FRONT FIXED HOOD	SERVICE PART 191-504
6.	106-386	12	FLG LOCKNUT (M8-1.25)	
7.	106-381	6	FLG LK SCREW (M8-1.25 X 25MM)	
8.	118-183	AR	BULK EDGE (SOLD BY FOOT)	USE 1 @ 146"
9.	106-388	2	WASHER (M6)	
10.	105-688	2	SCREW (M6-1.00 X 35MM)	
11.	118-199	1	PUSH BUTTON HANDLE	
12.	110-564	1	HOOD LATCH	
13.	105-085	1	LOCKNUT (1/4-NC)	
14.	106-237	4	LOCKNUT (M6-1.00,PRV TRQ,NLK)	
15.	118-183	AR	BULK EDGE (SOLD BY FOOT)	USE 1 @ 63"
16.	323-731	1	LATCH ARM	
17.	106-387	2	FLG LOCKNUT (M10-1.50)	
18.	178-151	1	BOSS	
19.	105-271	2	SCREW (M10-1.5 X 40MM)	
20.	105-797	2	FLG SCREW (M6-1.00 X 20MM, BX)	
21.	105-805	1	BELLEVILLE WASHER (3/8")	
22.	106-093	1	SCREW (M6-1.00 X 45MM)	USE LOCKTITE 242
23.	179-926	1	SPACER	
24.	110-281	1	ROD END (1/4-NF, FM, RH)	
25.	110-282	1	ROD END (1/4-NF, FM, LH)	
26.	361-676	1	THREADED ROD	
27.	502-651	3	SCREW (M6-1.00 X 35MM)	
28.	108-112	3	STUD BOLT (M8-1.25 X 70MM)	
29.	105-152	1	NUT (1/4-NF)	
30.	300-6589	1	BOSS	

NOT SHOWN:

FOOTNOTES:

NOTE:

REAR HOODS

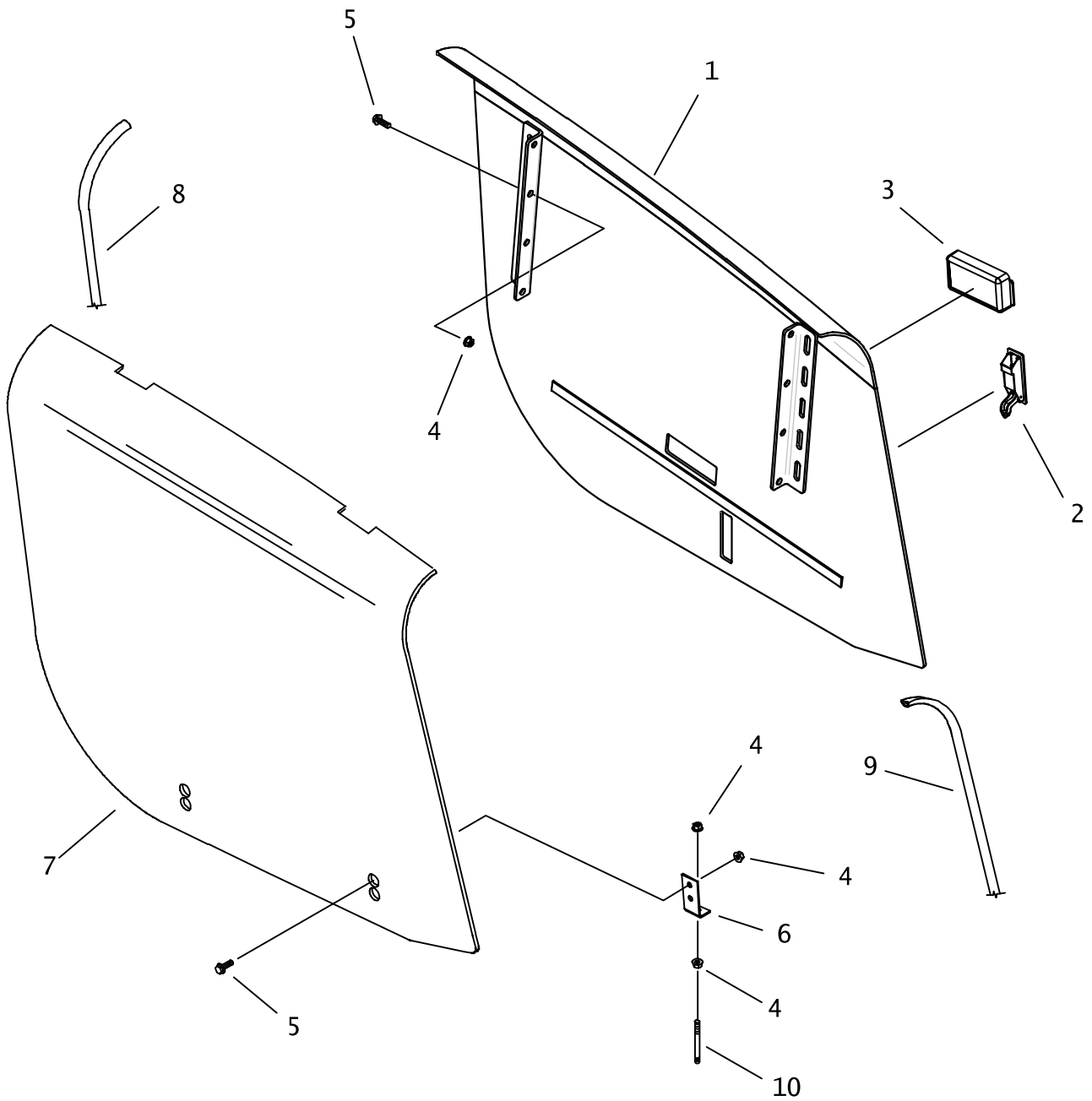

REAR HOODS

REF NO.	PART NUMBER	QTY	DESCRIPTION	REMARKS
1.	327-716	1	REAR HOOD	SERVICE PART I9I-505
2.	117-558	1	ADJ LEVER LATCH (LOCKING)	
3.	117-427	1	POCKET PULL	
4.	106-386	22	FLG LOCKNUT (M8-1.25)	
5.	106-162	18	FLG SCREW (M8-1.25 X 20MM)	
6.	319-394	2	BRACKET	
7.	327-718	1	REAR FIXED HOOD	SERVICE PART I9I-506
8.	118-183	AR	BULK EDGE (SOLD BY INCH)	USE 1 @ 92"
9.	118-183	AR	BULK EDGE (SOLD BY INCH)	USE 1 @ 92"
10.	108-112	2	STUD BOLT (M8-1.25 X 70MM)	

NOT SHOWN:

FOOTNOTES:

NOTE:

SOUND INSULATION - ENGINE ENCLOSURE

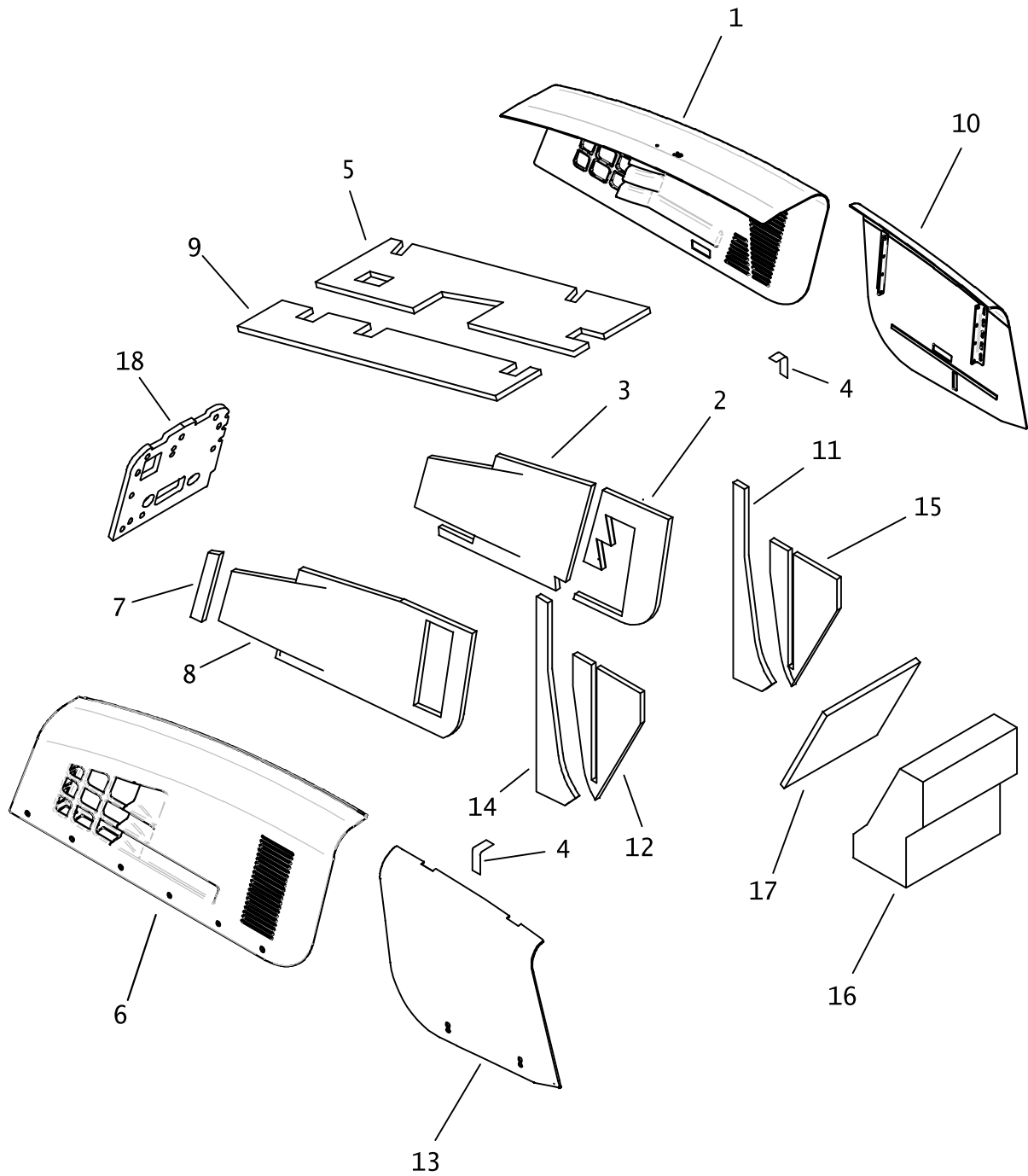

SOUND INSULATION - ENGINE ENCLOSURE

REF NO.	PART NUMBER	QTY	DESCRIPTION	REMARKS
1.	325-956	-	FRONT HOOD	
2.	118-099	1	SOUND INSULATION	
3.	118-100	1	SOUND INSULATION	
4.	118-187	AR	FOIL TAPE(HI-TEMP ALUM)2"WD	USE 12 @ 14"
5.	118-098	1	SOUND INSULATION	
6.	325-955	-	FRONT FIXED HOOD	
7.	118-102	1	SOUND INSULATION	
8.	118-103	1	SOUND INSULATION	
9.	118-104	1	SOUND INSULATION	
10.	327-716	-	REAR HOOD	
11.	118-106	1	SOUND INSULATION	
12.	118-108	1	SOUND INSULATION	
13.	327-718	-	REAR FIXED HOOD	
14.	118-105	1	SOUND INSULATION	
15.	118-107	1	SOUND INSULATION	
16.	364-641	-	HYDRAULIC RESERVOIR	
17.	118-109	1	SOUND INSULATION	
18.	118-165	1	SOUND INSULATION	

NOT SHOWN:

FOOTNOTES:

NOTE:

REAR CONTROLS

JT12M1

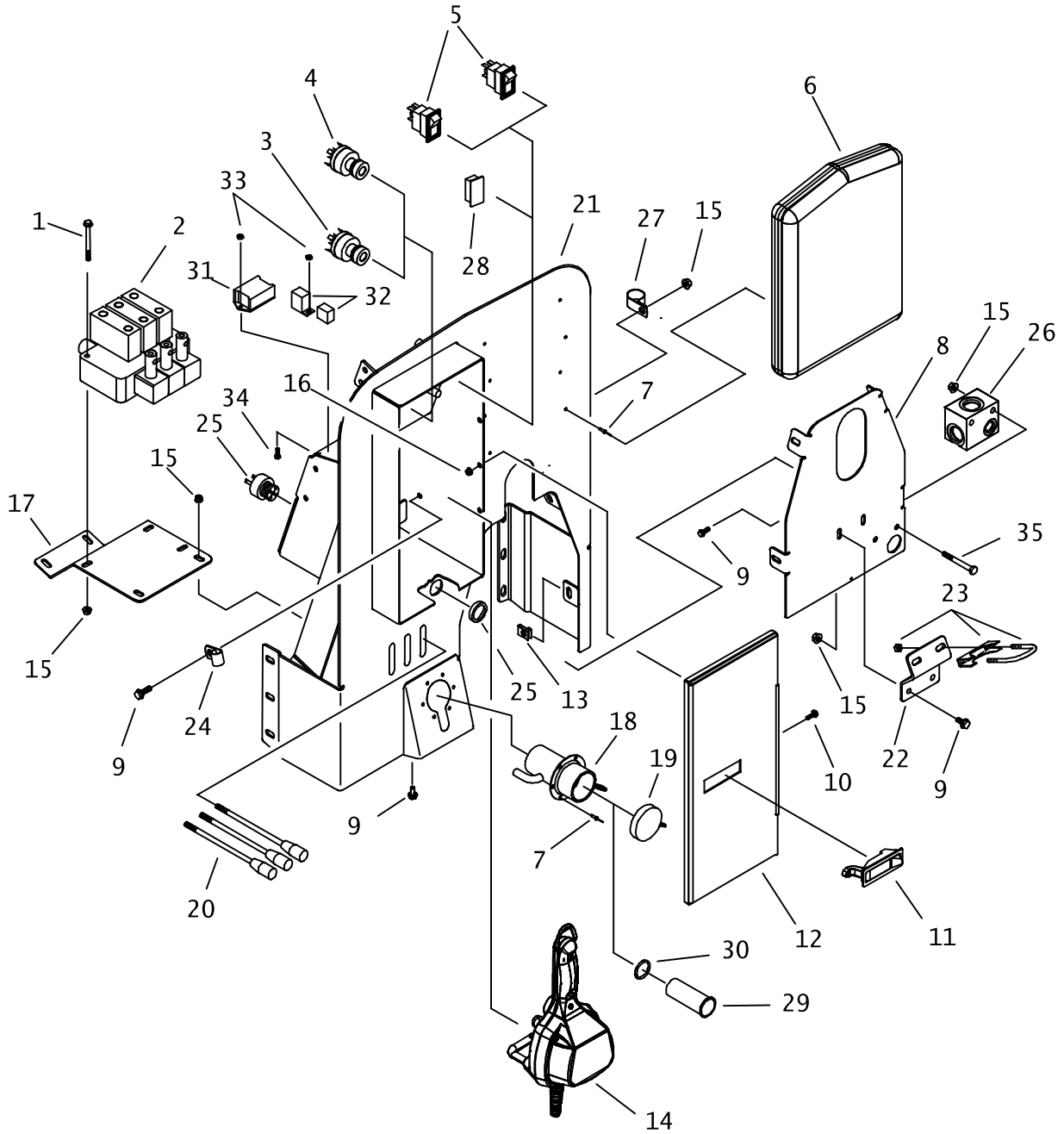

REAR CONTROLS

JT12M1

REF NO.	PART NUMBER	QTY	DESCRIPTION	REMARKS
1.	106-570	3	SCREW (M8-1.25 X 60MM)	
2.	157-240	1	SET UP VALVE	
3.	214-908	1	ON-OFF KEY SWITCH	
4.	214-852	1	IGNITION SWITCH	
5.	214-489	2	ROCKER SW (DPDT) (ON)-OFF-(ON)	
6.	318-588	1	MANUAL COMPARTMENT	
7.	110-560	10	POP RIVET (3/16" X 1/2", ALUM)	
8.	318-696	1	COVER PLATE	
9.	106-162	11	FLG SCREW (M8-1.25 X 20MM, GD8)	
10.	107-193	3	SCREW (M6-1.00 X 16MM BUT SOC)	
11.	117-558	1	LEVER LATCH (LOCKING)	
12.	318-736	1	DOOR	
13.	106-551	4	CLIP NUT (M8-1.25)	
14.	214-589	1	GROUND DRIVE CONTROL	
15.	106-386	12	FLG LOCKNUT (M8-1.25)	
16.	106-385	3	FLG LOCKNUT (M6-1.00)	
17.	318-476	1	VALVE MOUNT	
18.	364-661	1	FILLER NECK	INCLUDES REF NO. 19
19.	153-760	-	CAP	
20.	365-426	3	LEVER (M8-1.25 X 200MM)	
21.	318-656	-	BACK PLATE	
22.	322-614	1	CLAMP BRACKET	
23.	196-071	1	U-BOLT CLAMP (1-5/8")	
24.	110-126	1	BOLT-ON CLAMP (1/2")	
25.	306-603	1	AUDIO ALARM	
26.	159-791	-	HYDRAULIC MANIFOLD BLOCK	
27.	110-333	1	BOLT-ON CLAMP (1")	
28.	110-962	1	FILLER PLUG	
29.	364-663	1	FILLER NECK SCREEN	
30.	155-708	1	O-RING (906 D90)	
31.	217-184	1	DELAY TIMER (2-SECOND)	
32.	217-710	1	MICRO RELAY (SPDT)	
33.	106-048	3	LOCKNUT (#10-24)	
34.	105-185	3	BOLT (#10-24 X 1/2", RD SLT)	
35.	106-330	2	SCREW (M8-1.25 X 70MM)	

NOT SHOWN:

FOOTNOTES:

NOTE:

COMPONENT MOUNTING

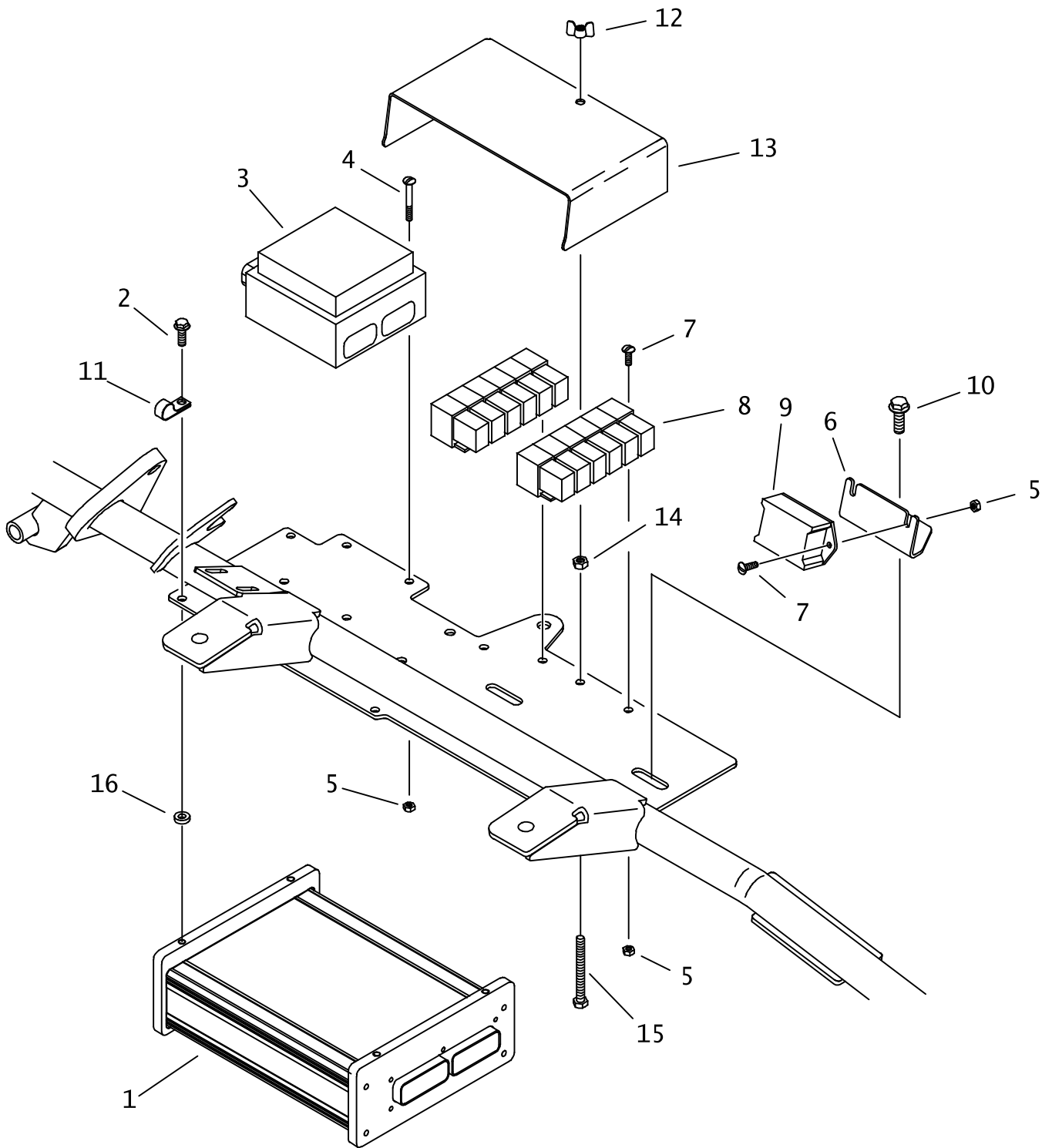

COMPONENT MOUNTING

REF NO.	PART NUMBER	QTY	DESCRIPTION	REMARKS
1.	220-1023	1	JT CONTROLLER 2	
2.	106-712	4	FLG SCREW (M6-1.00 X 16MM)	
3.	214-905	1	BUSSMAN V.E.C.	REPLACEMENT LID 500-I859
4.	105-816	4	SCREW (#10-24 X1-1/2", PAN SLT)	
5.	106-048	10	LOCKNUT (#10-24)	
6.	322-860	1	DIODE BRACKET	
7.	105-185	6	BOLT (#10-24 X 1/2 ", RD SLT)	
8.	217-710	13	MICRO RELAY (SPDT)	
9.	211-026	1	DIODE PACK (DEUTSCH)	
10.	106-381	-	FLG LK SCREW (M8-1.25 X 25MM)	
11.	110-332	2	BOLT-ON CLAMP (1-5/8")	
12.	195-339	1	WING NUT (1/4-NC)	
13.	324-567	1	RELAY COVER	SEE FOOTNOTE 1
14.	105-078	1	NUT (1/4-NC)	
15.	108-116	1	SCREW (1/4-NC X 2-1/2", GD5)	
16.	155-751	4	WASHER (1/4", NEOPRENE)	

NOT SHOWN:

FOOTNOTES:

1- IF ORIGINAL COVER HAS A CUT-OUT TO FIT AROUND THE AIR FILTER RESTRICTION INDICATOR A REPLACEMENT COVER WILL REQUIRE A SIMILAR CUT-OUT.

NOTE:

BATTERY

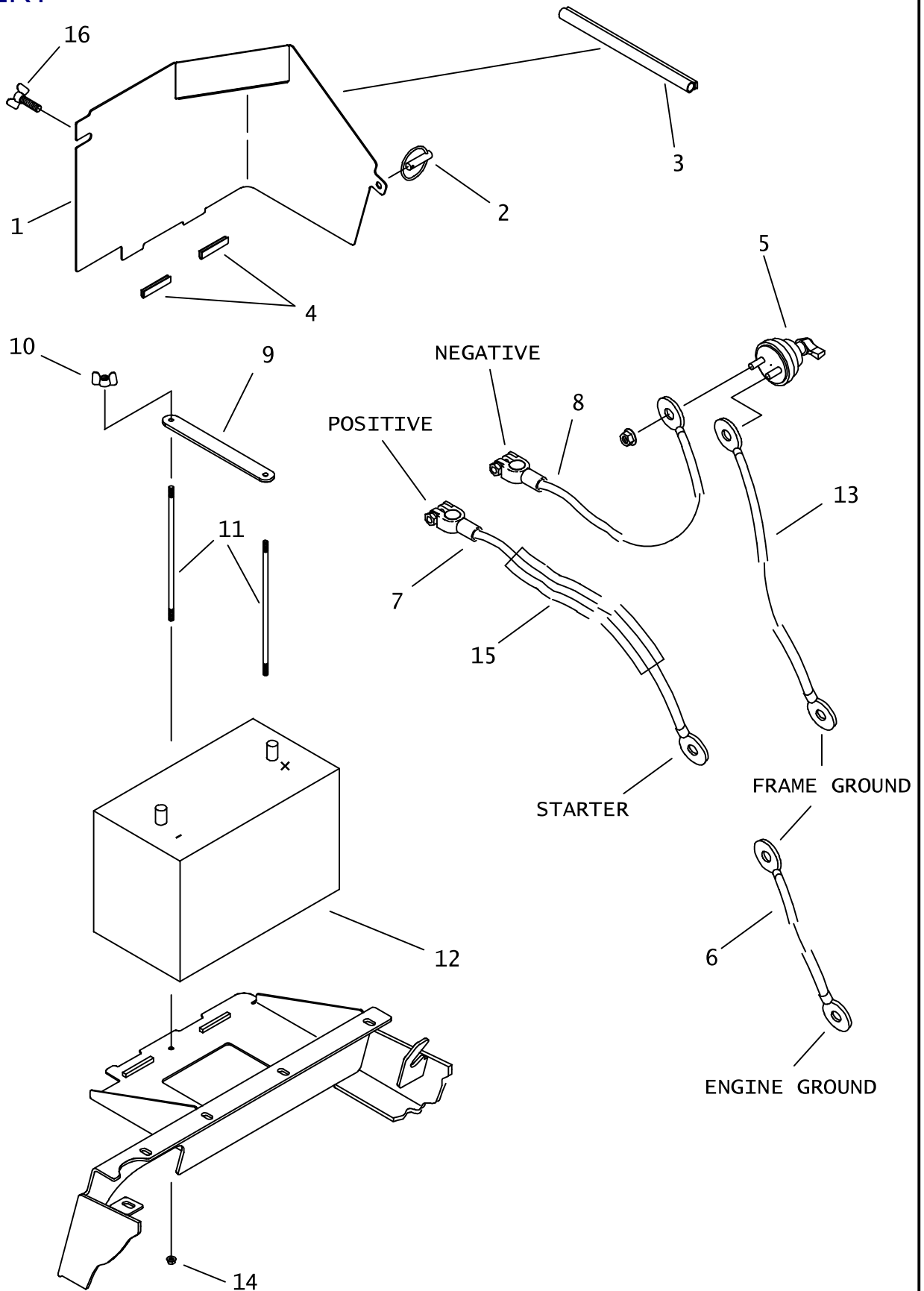

BATTERY

REF NO.	PART NUMBER	QTY	DESCRIPTION	REMARKS
1.	318-525	1	BATTERY COVER	
2.	110-737	1	PULL PIN (5/16" X 2")	
3.	116-421	AR	BULK EDGE (1/8",SOLD PER FT)	USE 1 @ 22"
4.	118-164	AR	BULK EDGE (1/16", SOLD PER FT)	USE 2 @ 3"
5.	217-819	1	BATTERY DISCONNECT SWITCH	
6.	215-355	1	BAT CABLE (2/0 GA X 36", BLK)	
7.	213-159	1	BAT CABLE (2/0 GA X 63", RED)	
8.	215-337	1	BAT CABLE (2/0 GA X 19", BLK)	
9.	108-189	1	BATTERY HOLD DOWN	
10.	195-339	2	WINGNUT (1/4-NC)	
11.	356-491	2	TIE DOWN ROD (1/4-NC X 9.3")	
12.	215-262	1	BATTERY (12V, 925 AMP)	
13.	213-160	1	BAT CABLE (2/0 GA X 24",BLACK)	
14.	105-832	2	FLG LOCKNUT (1/4-NC)	
15.	116-389	AR	BULK TUBING (3/4",SOLD PER FT)	INCLUDED WITH REF NO 7
16.	106-795	1	WING SCREW (M8-1.25 X 20MM)	

FOOTNOTES

NOTE:

H

808-412

FRAME COMPONENTS

ASSISTED MAKEUP SENSOR

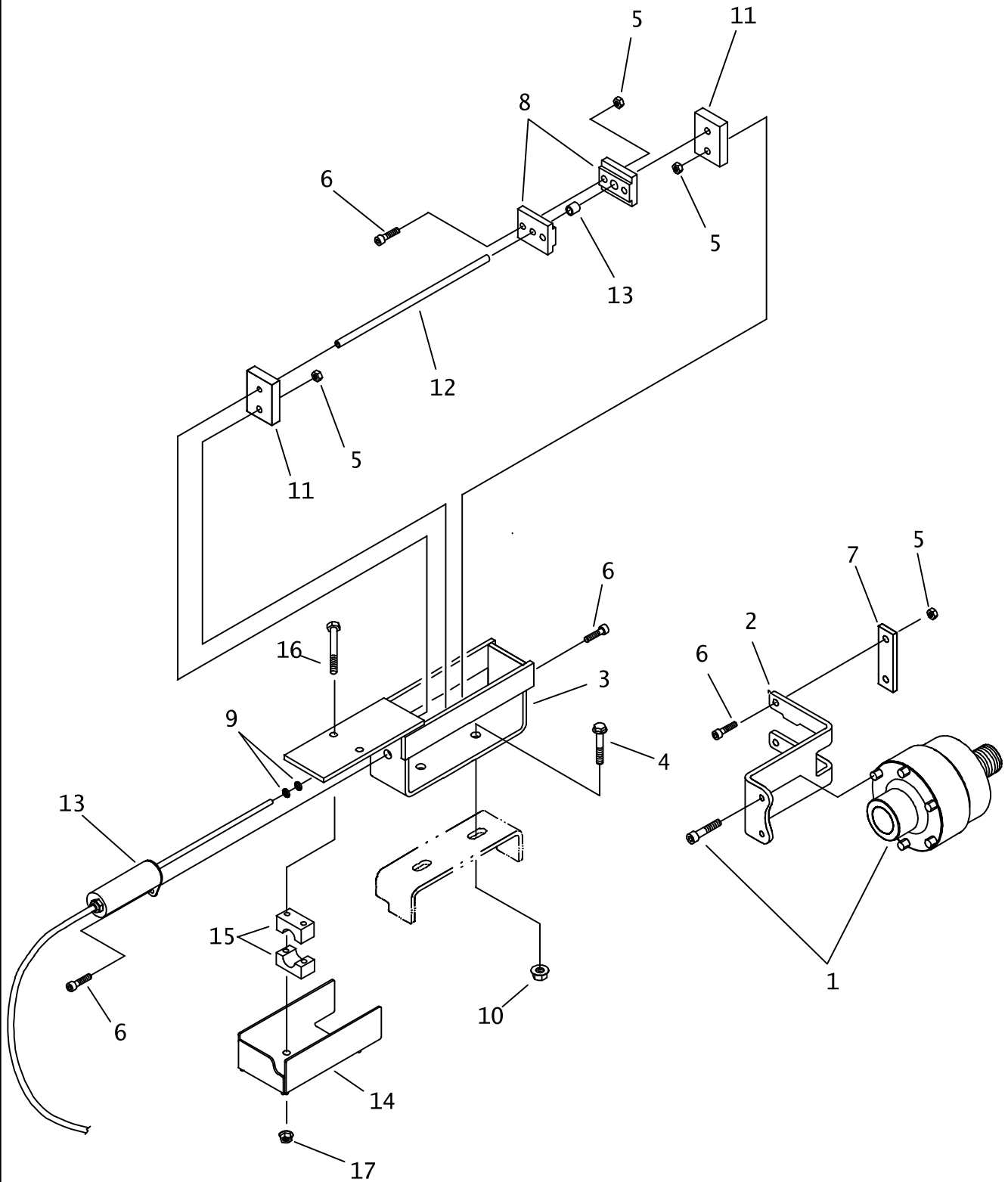

ASSISTED MAKEUP SENSOR

REF NO.	PART NUMBER	QTY	DESCRIPTION	REMARKS
1.	153-242	-	WATER SWIVEL (12NF-12NF)	
	191-248	-	SEAL KIT (153-242)	
2.	319-164	1	SENSOR GUIDE	
3.	319-160	1	SENSOR MOUNT	
4.	106-162	2	FLG SCREW (M8-1.25 X 20MM)	
5.	106-850	6	LOCKNUT (M5-0.80)	
6.	106-426	6	SCREW (M5-0.80 X 25MM SOC)	
7.	179-763	1	TIE BAR	
8.	319-165	2	MAGNET MOUNT	
9.	157-123	2	O-RING (008 D90)	
10.	106-386	2	FLG LOCKNUT (M8-1.25)	
11.	319-167	2	TUBING MOUNT	
12.	318-616	1	SENSOR TUBE	
13.	222-125	1	POSITION SENSOR	
	222-171	-	POSITION SENSOR MAGNET	
14.	323-904	1	SENSOR COVER	
15.	110-573	1	BOLT-ON CLAMP (1",SOLD PER SET)	
16.	107-025	2	SCREW (M6-1.00 X 50MM)	
17.	106-353	2	FLG NUT (M6-1.00)	

NOT SHOWN

FOOTNOTES

NOTE

H

808-388

CARRIAGE

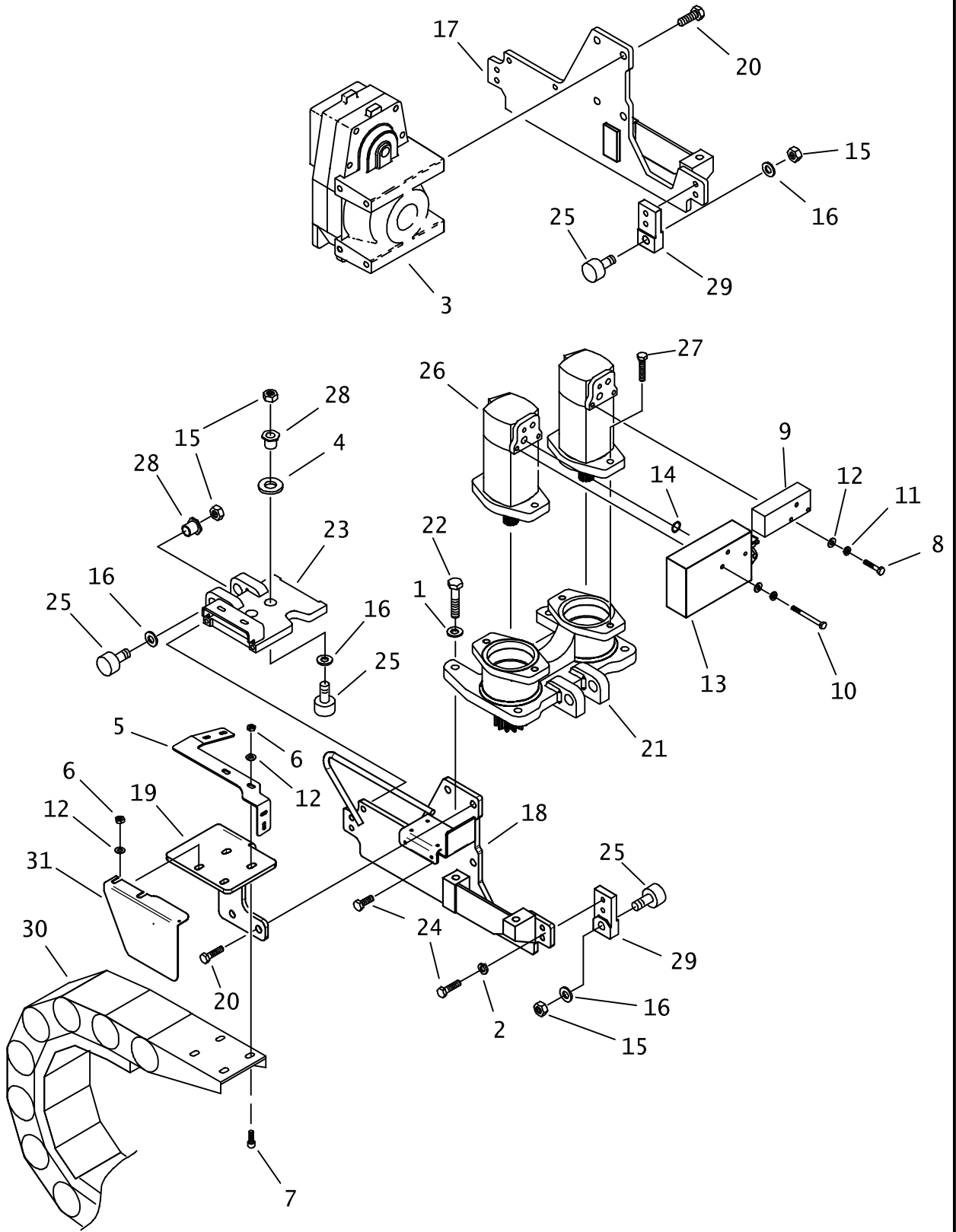

CARRIAGE

REF NO.	PART NUMBER	QTY	DESCRIPTION	REMARKS
1.	106-398	4	WASHER (M16, HARDENED)	
2.	106-030	8	LOCK WASHER (M12)	
3.	166-451	1	GEARBOX (1.78:1, ROTATION)	
4.	179-422	2	BOSS	
5.	318-873	1	BRACKET, TOP	
6.	105-047	8	LOCKNUT (3/8-NC)	
7.	105-249	8	CARRIAGE BOLT (3/8-NC X 1-1/4")	
8.	500-003	3	BOLT (3/8-NC X 2-3/4")	TORQUE TO 40 FT LBS, USE LOCKTITE 242
9.	150-2050	1	MANIFOLD	
	150-1327		HYDRAULIC CARTRIDGE	
	213-197		SOLENOID COIL	
	500-1310		10,12,16,20 SERIES SOLENOID NUT	
	500-1953		NUT, COIL RETAINING	
10.	105-258	3	BOLT (3/8-NC X 3-3/4")	TORQUE TO 40 FT LBS, USE LOCKTITE 242
11.	105-072	6	LOCK WASHER (3/8")	
12.	106-390	18	WASHER (M10)	
13.	150-2049	1	MANIFOLD	
	150-1328		HYDRAULIC CARTRIDGE	
	213-196		SOLENOID COIL	
	500-1308		SERIES 8 SOLENOID NUT	
	500-1953		NUT, COIL RETAINING	
14.	155-776	-	O-RING (117 D70)	
15.	105-388	10	NUT (3/4-NF)	TORQUE TO 62 FT LBS
16.	106-949	10	WASHER (3/4", HARDENED)	
17.	325-312	1	LEFT SIDE PLATE	
18.	300-2816	1	RIGHT SIDE PLATE	
19.	327-581	1	HOSE CARRIER MOUNT	
20.	105-998	8	SCREW (M16-2.00 X 40MM)	TORQUE TO 140 FT LBS, USE LOCKTITE 242
21.	166-448	1	PINION DRIVE	
22.	107-197	4	SCREW (M16-2.00 X 80MM,10.9)	TORQUE TO 200 FT LBS, USE LOCKTITE 242
23.	318-353	1	REAR PLATE	
24.	105-273	12	SCREW (M12-1.75 X 30MM)	TORQUE TO 55 FT LBS, USE LOCKTITE 242
25.	141-730	10	ROLLER	
26.	157-317	2	MOTOR	
	500-1269	-	SEAL REPAIR KIT	
27.	106-472	4	SCREW (M14-2.00 X 35MM)	TORQUE TO 88 FT LBS, USE LOCKTITE 242
28.	179-704	6	ECCENTRIC BUSHING	
29.	318-344	4	LOWER ROLLER MOUNT	
30.	318-561	1	HOSE TRACK (5" X 120")	
	118-254	-	INNER HOSE BAG	
	118-273	-	OUTER HOSE BAG	
	324-614	-	EZ OUT BAR (.50" X 3.17")	
	324-615	-	EZ OUT BAR (.50" X 4.28")	
31.	327-618	1	SHIELD	

FOOTNOTES:

NOTE:

CARRIAGE SPINDLE

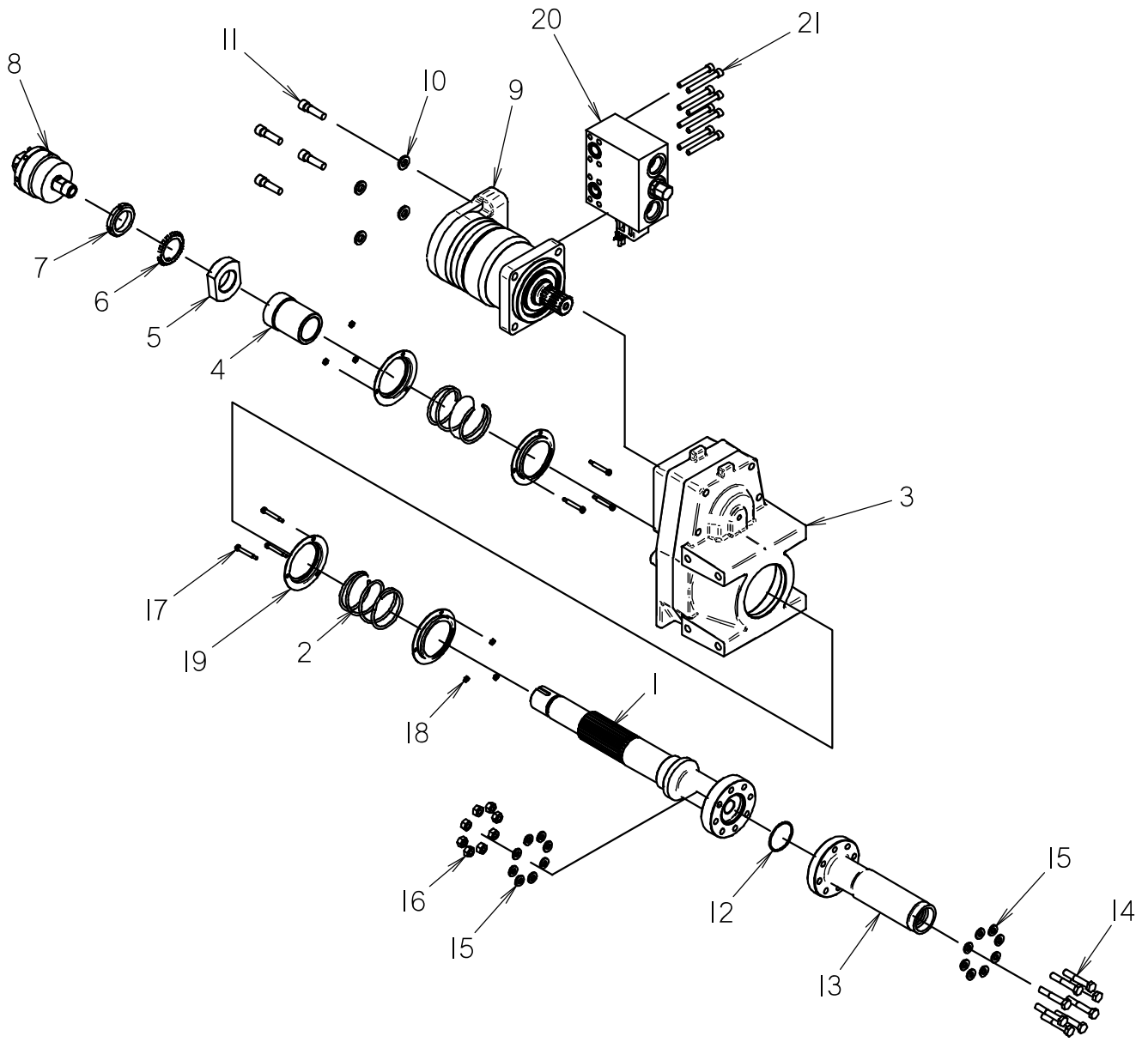

CARRIAGE SPINDLE

REF NO.	PART NUMBER	QTY	DESCRIPTION	REMARKS
1	166-426	1	SLIDING OUTPUT SHAFT	APPLY 256-666 GREASE TO SPLINES
2	118-292	2	COMPRESSION SPRING	SEE FOOTNOTE 1
3	166-451	1	GEAR BOX	
4	177-034	1	SHAFT SPACER	
5	106-865	1	NUT	
6	185-074	1	TANG LOCK WASHER (1.792")	
7	185-067	1	THRUST LOCKNUT (1.767-NF-18)	
8	153-242	1	WATER SWIVEL (12N-12NF)	SEE FOOTNOTE 2
9	150-1026	1	ROTATION MOTOR	
10	106-397	4	WASHER (M12, HARDENED)	
11	106-707	4	SCREW (M12-1.75 X 45MM, SOC)	USE LOCTITE 242
12	157-019	1	O-RING (139 D90)	
13	400-604	1	SAVER SUB (1.47-4 F DS)	
14	106-642	8	SCREW (M10-1.50 X 65MM)	TORQUE TO 47 FT LBS
15	106-396	16	WASHER (M10, HARDENED)	
16	105-894	8	LOCKNUT (M10-1.50, PRV TRQ, 10.9)	
17	108-120	6	SHLD BLT (1/4" X 1-1/2", #10-24)	
18	106-048	6	LOCKNUT (#10-24)	
19	159-898	4	SPRING CAP	
20	159-577	1	RELIEF MANIFOLD	SERVICE PARTS INCLUDE: 150-1326 HYDRAULIC VALVE
21	105-857	8	BOLT (3/8-NC X 3", SOC, GD8)	

NOT SHOWN:

FOOTNOTES:

1. SUPERSEDES 117-921 COMPRESSION SPRING, 117-921 DOES NOT USE SPRING CAPS (REF 19)
2. INSTALL USING NICKLE THREAD SEALING TAPE (117-555) ON MALE THREADS, 191-248 SEAL KIT

NOTE:

ROTATION GEAR BOX

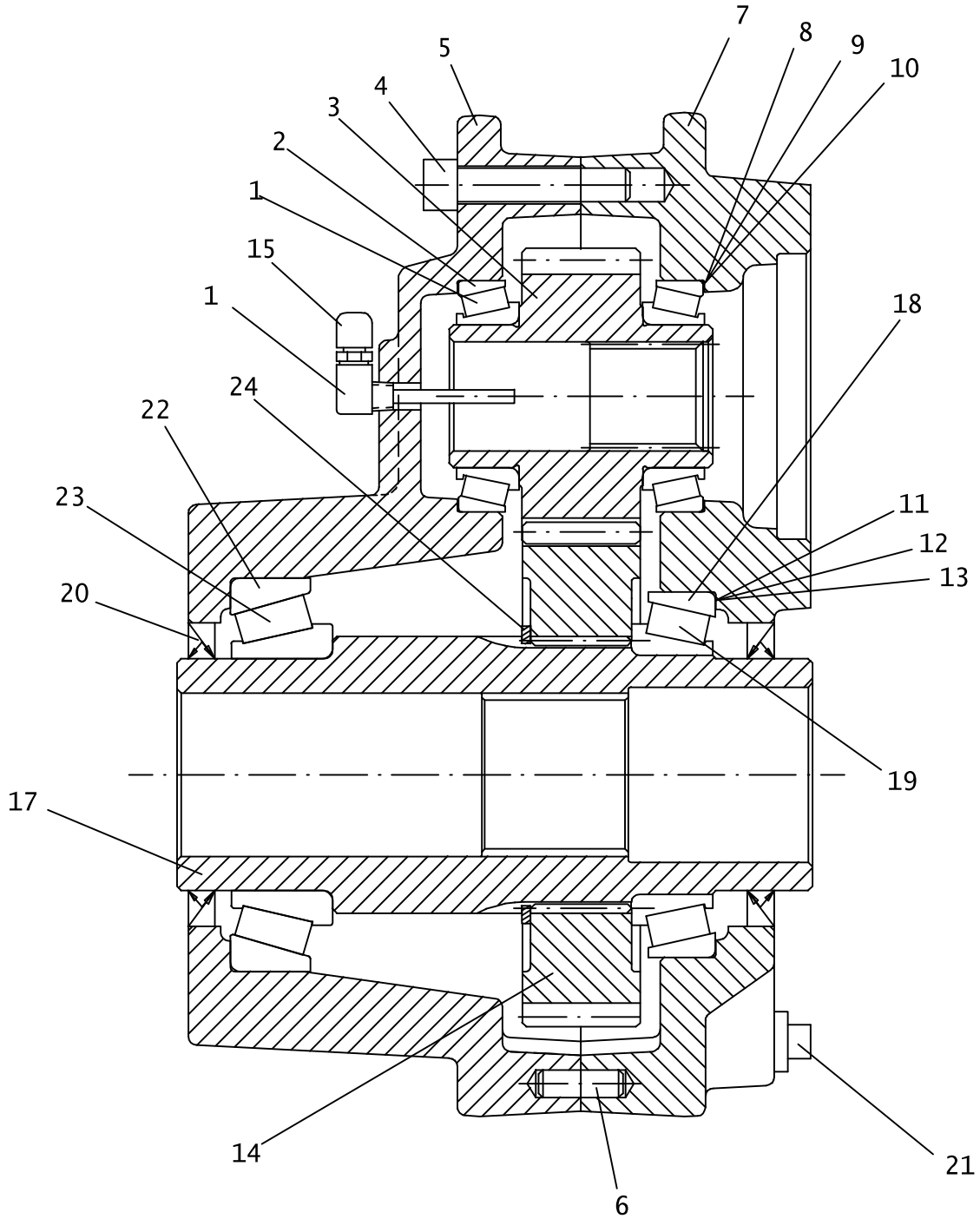

ROTATION GEAR BOX

REF NO.	PART NUMBER	QTY	DESCRIPTION	REMARKS
	166-451		GEAR BOX (1.78:1 ROTATION)	INCL REF NO.'S 1 - 24
1.	126-100	2	TAPERED BEARING (2")	
2.	126-099	2	TAPERED RACE (3.25")	
3.	166-528	1	INPUT PINION	
4.	106-771	10	SCREW (M12-1.75 X 60MM, SOC)	
5.	162-027	1	GEARBOX HOUSING	
6.	106-866	2	DOWEL PIN (10MM X 30MM)	
7.	162-004	1	GEARBOX COVER	
8.	165-800	5	SHIM (.002")	
9.	165-801	5	SHIM (.003")	
10.	165-802	5	SHIM (.007")	
11.	165-829	5	SHIM (.002")	
12.	165-830	5	SHIM (.003")	
13.	165-828	5	SHIM (.007")	
14.	160-1102	1	OUTPUT GEAR	
15.	159-003	1	AIR VENT (02N)	
16.	514-123	1	PICKUP TUBE (02N-02NF90-2")	
17.	166-434	1	OUTPUT SHAFT	
18.	126-076	1	TAPERED RACE (5.118")	
19.	126-075	1	TAPERED BEARING (3.346")	
20.	155-869	2	INTERNAL SEAL (3.250")	
21.	115-211	2	PLUG (08N,SQ, MAG)	
22.	126-157	1	TAPERED RACE	
23.	126-156	1	TAPERED BEARING	
24.	115-896	1	EXTERNAL SNAP RING (3.875")	

NOT SHOWN:

FOOTNOTES:

NOTE:

PINION DRIVE ASSEMBLY

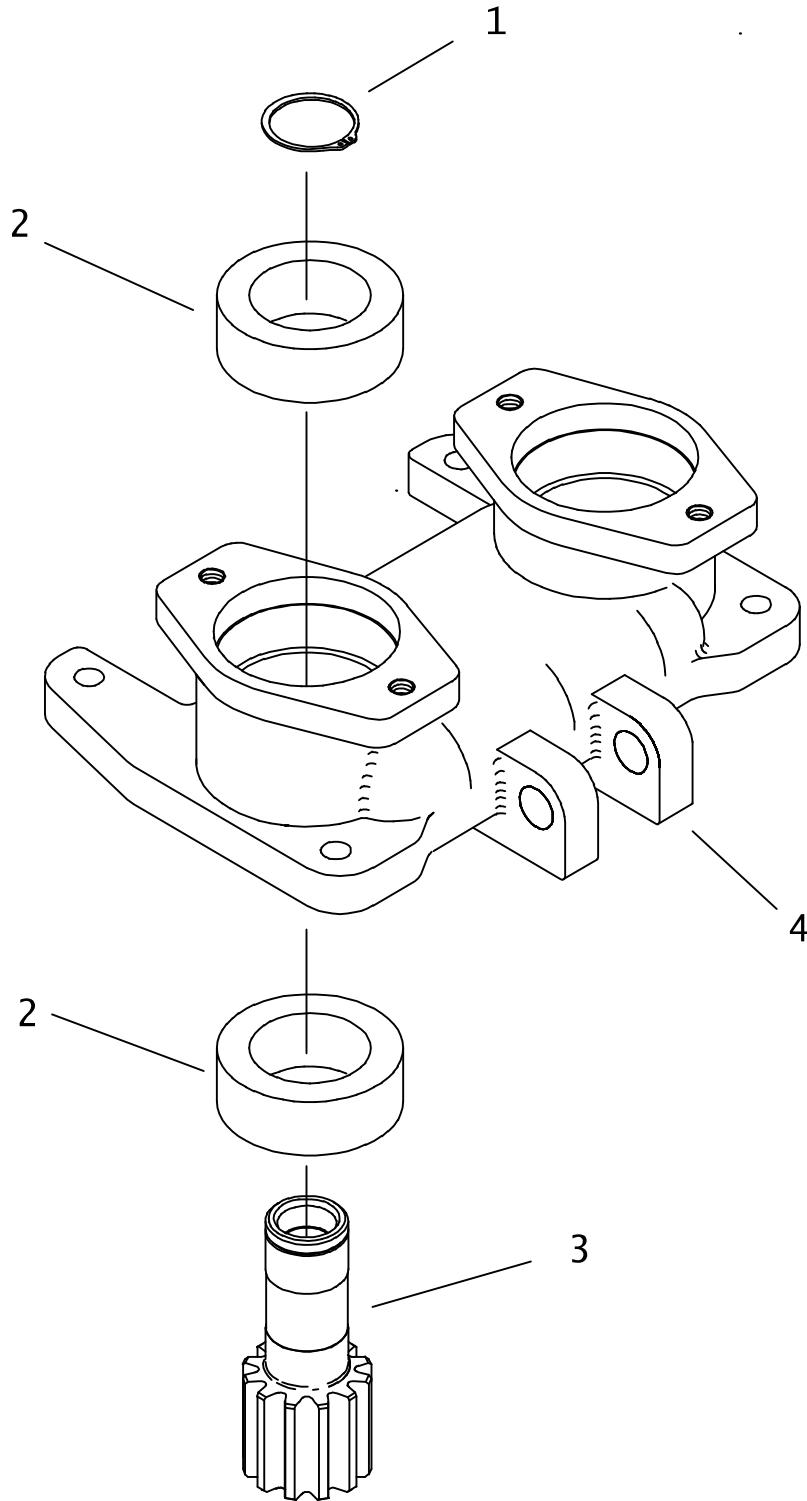

PINION DRIVE ASSEMBLY

REF NO.	PART NUMBER	QTY	DESCRIPTION	REMARKS
	166-448	-	PINION DRIVE	
1.	115-456	2	EXTERNAL SNAP RING	
2.	125-044	4	BALLBEARING (1.717")	
3.	160-1019	2	PINION	
4.	318-351	1	MOTOR PLATE	

NOT SHOWN:

FOOTNOTES:

NOTE:

PIPE GUIDE

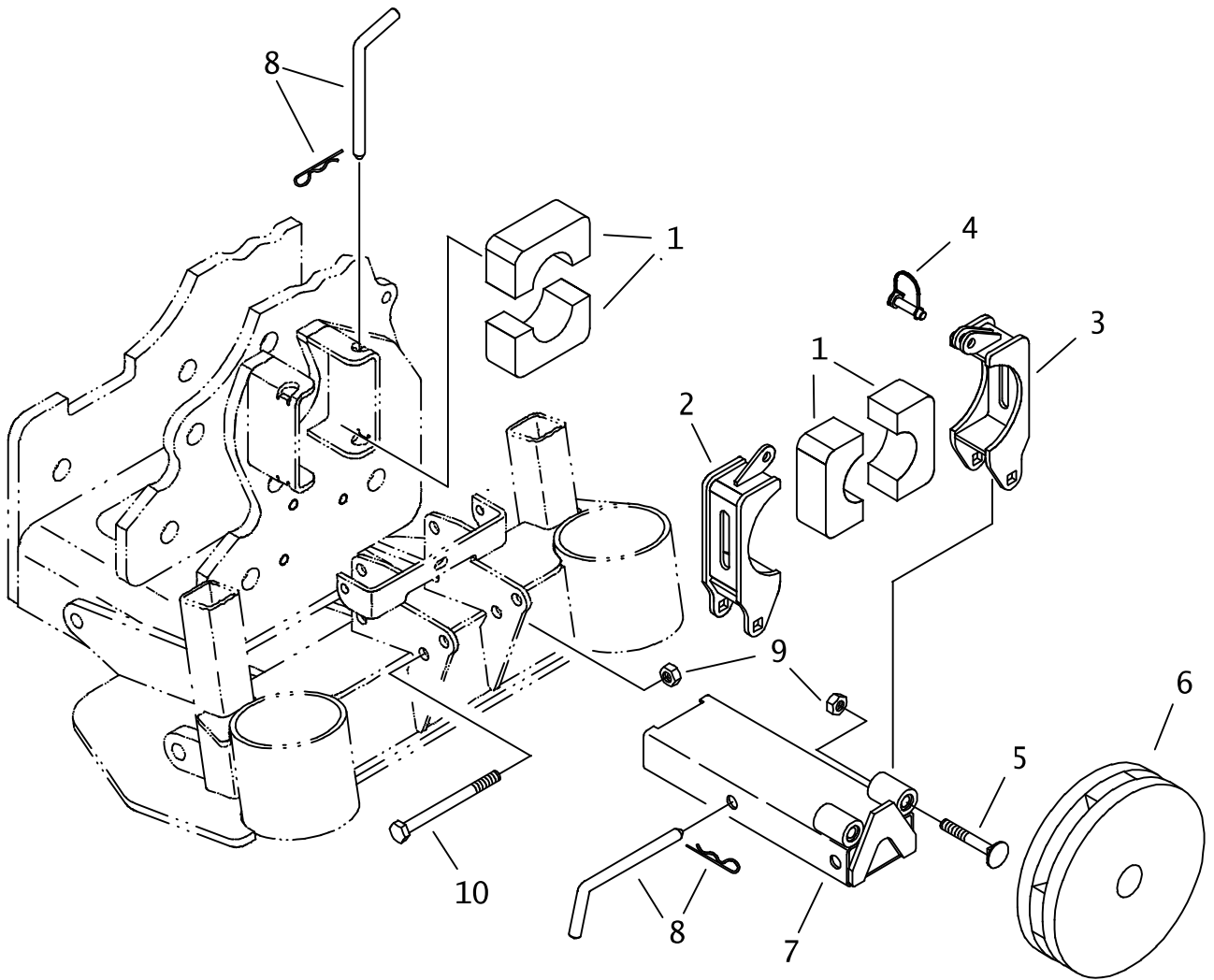

PIPE GUIDE

REF NO.	PART NUMBER	QTY	DESCRIPTION	REMARKS
1.	362-1060	4	PIPE GUIDE	
2.	320-814	1	RIGHT PIPE GUIDE RETAINER	
3.	320-802	1	LEFT PIPE GUIDE RETAINER	
4.	110-368	1	SNAPPER PIN (3/8" X 1-1/2")	
5.	107-590	2	CARRIAGE BOLT (M12-1.75 X 80MM)	
6.	149-974	1	SPLIT ROD WIPER (1.5" ID)	
7.	318-863	1	PIPE GUIDE MOUNT	
8.	107-870	3	PULL PIN (.5" X 5")	
	110-033	-	HAIR CLIP PIN (1/8" X 1/2")	
9.	106-685	5	LOCKNUT(M12-1.75,PRV TRQ,10.9)	
10.	106-855	3	SCREW (M12-1.75 X 140MM)	

NOT SHOWN:

FOOTNOTES:

NOTE:

ROTATING WRENCH

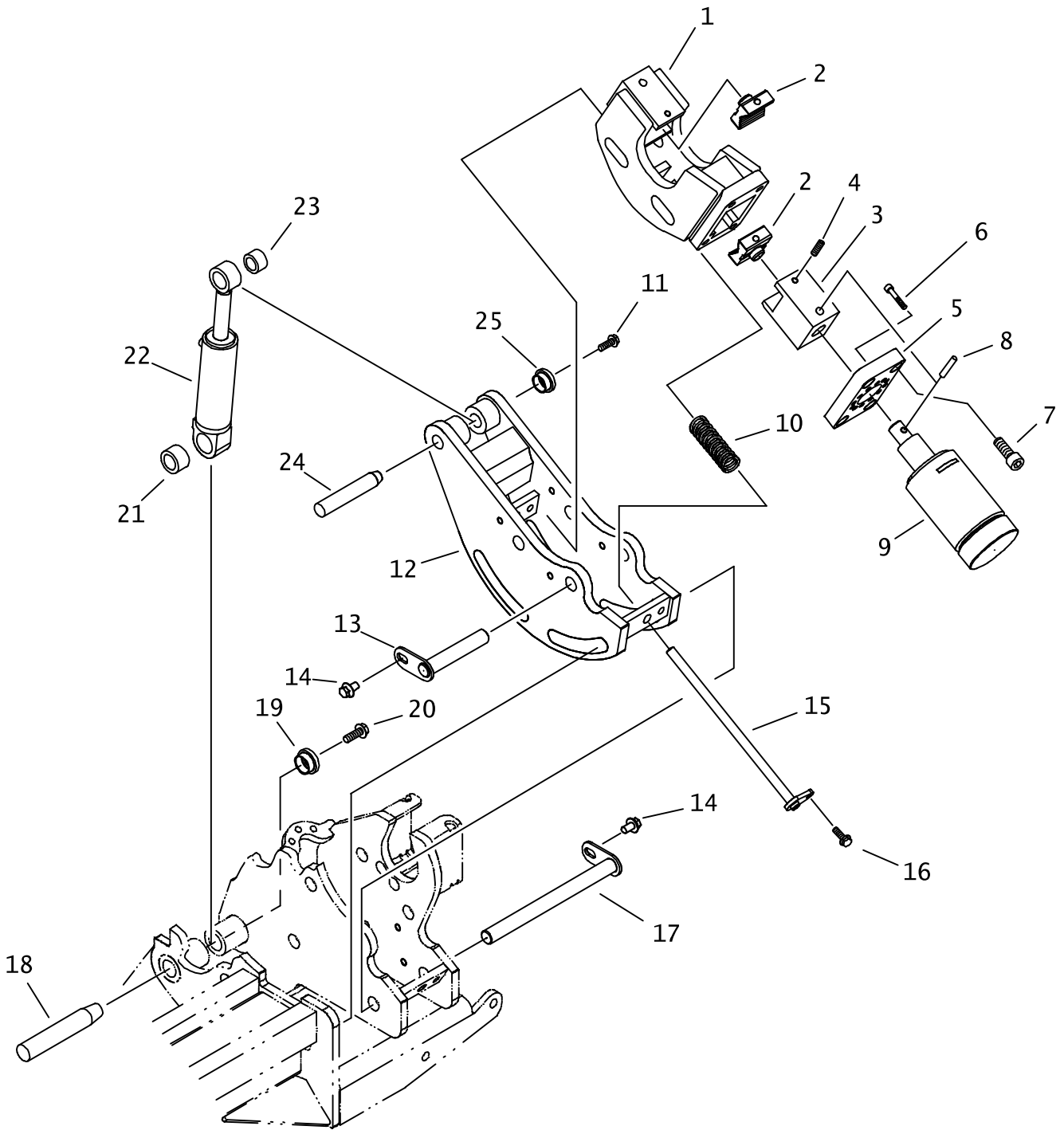

ROTATING WRENCH

REF NO.	PART NUMBER	QTY	DESCRIPTION	REMARKS
1.	316-460	1	REAR WRENCH	
2.	357-222	2	JAW INSERT	
3.	357-225	1	JAW	
4.	106-529	2	SET SCREW (M10-1.50 X 10MM)	LOCTITE 242
5.	316-545	1	CYL HEAD PLATE	
6.	107-894	10	SCREW (M8-1.25 X 45MM, SOC)	LOCTITE 242
7.	107-884	4	SCREW (M16-2.00 X 45MM, SOC)	LOCTITE 242
8.	105-561	1	ROLL PIN (3/8" X 2-3/4")	
9.	151-213	1	CYL (3.5 X 1.75 X 2.0)	
10.	118-115	1	COMPRESSION SPRING	
11.	106-724	1	FLG SCREW (M10-1.50 X 25MM)	
12.	324-918	1	ROTATING WRENCH	
13.	318-511	2	WRENCH PIN - SHORT	
14.	105-1012	4	FLG LK SCREW (M12-1.75 X 20MM)	
15.	316-462	1	CENTERING PIN	
16.	106-383	1	FLG LK SCREW (M10-1.50 X 30MM)	
17.	318-512	2	WRENCH PIN - LONG	
18.	178-225	1	TAPERED PIN (31.7MM X 181.6MM)	
19.	181-982	1	TAPERED INSERT (1.25")	
20.	106-469	1	FLG SCREW (M12-1.75 X 30MM)	
21.	125-771	1	COMPOSITION BUSHING (1.25")	
22.	151-038	1	CYL (2.0 X 1.0 X 4.0)	
23.	125-770	1	COMPOSITION BUSHING (1")	
24.	179-987	1	TAPERED PIN (1" X 5.50")	
25.	181-981	1	TAPERED INSERT (1")	

NOT SHOWN:

FOOTNOTES:

NOTE:

ROTATING WRENCH

BEGINS WITH S/N:

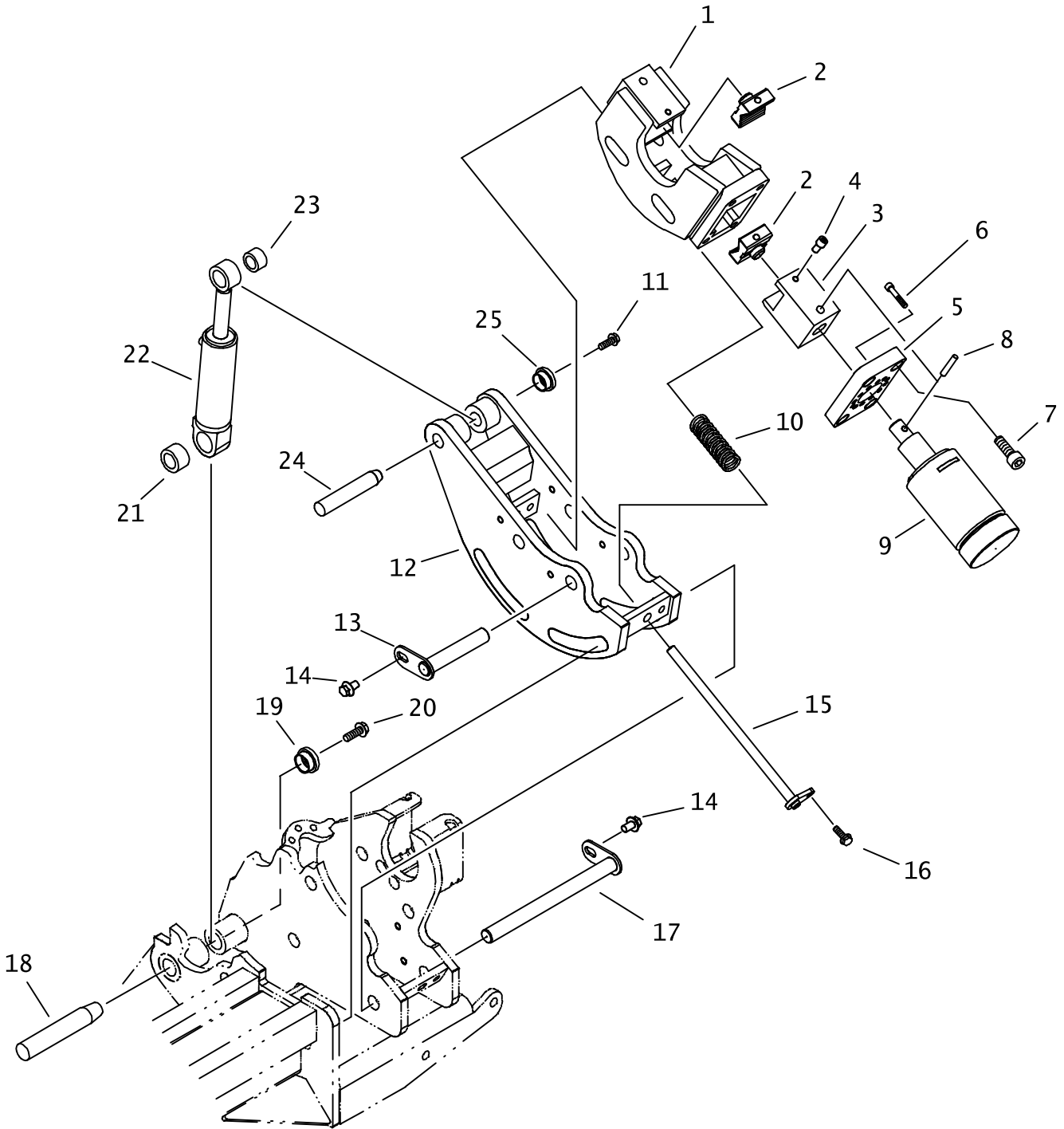

ROTATING WRENCH

BEGINS WITH S/N:

REF NO.	PART NUMBER	QTY	DESCRIPTION	REMARKS
1.	300-2509	1	REAR WRENCH	BEGINS WITH S/N: CMWJI220K60000126
2.	357-222	2	JAW INSERT	
3.	357-225	1	JAW	
4.	106-847	2	SCREW (M10-1.50 X 16MM, SOC)	LOCTITE 242
5.	316-545	1	CYL HEAD PLATE	
6.	107-894	10	SCREW (M8-1.25 X 45MM, SOC)	LOCTITE 242
7.	107-884	4	SCREW (M16-2.00 X 45MM, SOC)	LOCTITE 242
8.	105-561	1	ROLL PIN (3/8" X 2-3/4")	
9.	151-213	1	CYL (3.5 X 1.75 X 2.0)	
10.	118-115	1	COMPRESSION SPRING	
11.	106-724	1	FLG SCREW (M10-1.50 X 25MM)	
12.	324-918	1	ROTATING WRENCH	
13.	318-511	2	WRENCH PIN - SHORT	
14.	105-1012	4	FLG LK SCREW (M12-1.75 X 20MM)	
15.	316-462	1	CENTERING PIN	
16.	106-383	1	FLG LK SCREW (M10-1.50 X 30MM)	
17.	318-512	2	WRENCH PIN - LONG	
18.	178-225	1	TAPERED PIN (31.7MM X 181.6MM)	
19.	181-982	1	TAPERED INSERT (1.25")	
20.	106-469	1	FLG SCREW (M12-1.75 X 30MM)	
21.	125-771	1	COMPOSITION BUSHING (1.25")	
22.	151-038	1	CYL (2.0 X 1.0 X 4.0)	
23.	125-770	1	COMPOSITION BUSHING (1")	
24.	179-987	1	TAPERED PIN (1" X 5.50")	
25.	181-981	1	TAPERED INSERT (1")	

NOT SHOWN:

FOOTNOTES:

NOTE:

STATIONARY WRENCH

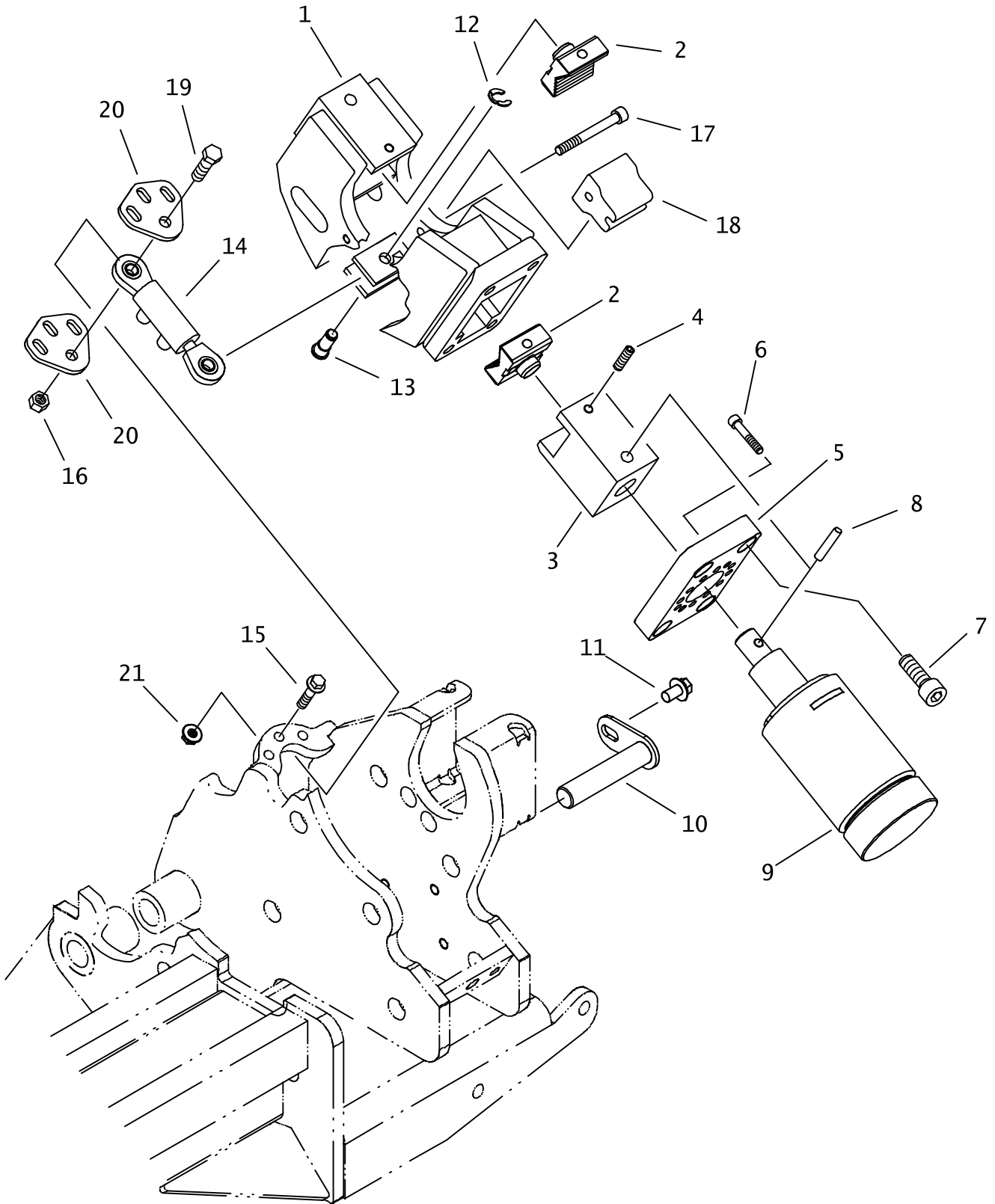

STATIONARY WRENCH

REF NO.	PART NUMBER	QTY	DESCRIPTION	REMARKS
1.	322-744	1	FRONT WRENCH	
2.	357-222	2	JAW INSERT	
3.	357-225	1	JAW	
4.	106-529	2	SET SCREW (M10-1.50 X 10MM)	LOCTITE 242
5.	316-545	1	CYL HEAD PLATE	
6.	107-894	10	SCREW (M8-1.25 X 45MM, SOC)	LOCTITE 242
7.	107-884	4	SCREW (M16-2.00 X 45MM, SOC)	LOCTITE 242
8.	105-561	1	ROLL PIN (3/8" X 2-3/4")	
9.	151-213	1	CYL (3.5 X 1.75 X 2.0)	
10.	318-511	2	WRENCH PIN - SHORT	
11.	105-1012	2	FLG LK SCREW (M12-1.75 X 20MM)	
12.	115-506	1	KLIP RING (.500")	
13.	179-528	1	PIN	
14.	151-220	1	CYLINDER (1.0 X .50 X .90)	
15.	106-995	3	FLG LK SCREW (M10-1.50 X 45MM)	
16.	106-685	1	LOCKNUT(M12-1.75,PRV TRQ,10.9)	
17.	108-061	2	SCREW (M10-1.50 X 90MM, SOC)	
18.	322-677	1	PIPE SUPPORT	
19.	106-477	1	SCREW (M12-1.75 X 45MM, 10.9)	
20.	323-061	2	MOUNT PLATE	
21.	106-387	3	FLG LOCKNUT (M10-1.50)	

NOT SHOWN:

FOOTNOTES:

NOTE:

STATIONARY WRENCH

BEGIN WITH S/N:

REF NO.	PART NUMBER	QTY	DESCRIPTION	REMARKS
1.	300-2510	1	FRONT WRENCH	BEGINS WITH S/N: CMWJ1220K60000126
2.	357-222	2	JAW INSERT	
3.	357-225	1	JAW	
4.	106-847	2	SCREW (M10-1.50 X 16MM, SOC)	LOCTITE 242
5.	316-545	1	CYL HEAD PLATE	
6.	107-894	10	SCREW (M8-1.25 X 45MM, SOC)	LOCTITE 242
7.	107-884	4	SCREW (M16-2.00 X 45MM, SOC)	LOCTITE 242
8.	105-561	1	ROLL PIN (3/8" X 2-3/4")	
9.	151-213	1	CYL (3.5 X 1.75 X 2.0)	
10.	318-511	2	WRENCH PIN - SHORT	
11.	105-1012	2	FLG LK SCREW (M12-1.75 X 20MM)	
12.	115-506	1	KLIP RING (.500")	
13.	179-528	1	PIN	
14.	151-220	1	CYLINDER (1.0 X .50 X .90)	
15.	106-995	3	FLG LK SCREW (M10-1.50 X 45MM)	
16.	106-685	1	LOCKNUT(M12-1.75, PRV TRQ, 10.9)	
17.	107-295	2	ROLL PIN (.375" X 3.750")	
18.	322-677	1	PIPE SUPPORT	
19.	106-477	1	SCREW (M12-1.75 X 45MM, 10.9)	
20.	323-061	2	MOUNT PLATE	
21.	106-387	3	FLG LOCKNUT (M10-1.50)	

NOT SHOWN:

FOOTNOTES:

NOTE:

FUEL TANK

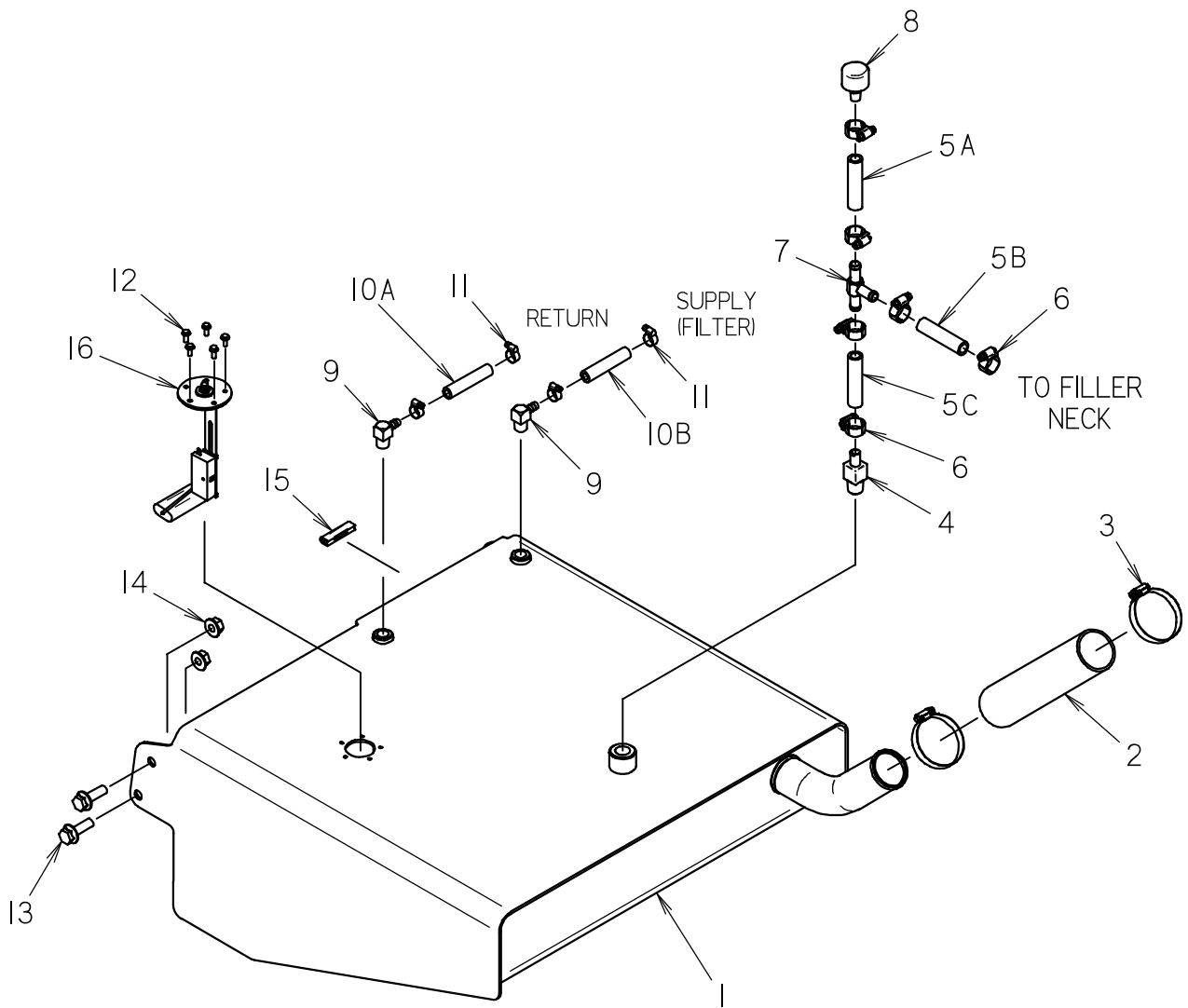

FUEL TANK

REF NO.	PART NUMBER	QTY	DESCRIPTION	REMARKS
1	300-7774	1	FUEL TANK	
2	116-1003	10	BULK HOSE (2", SOLD PER IN)	USE 1 @ 10"
3	110-134	2	WORM CLAMP (2.062" TO 2.750")	
4	514-312	1	S/O COUPLER (08N-08H)	
5	116-322	27	BULK HOSE (1/2",SOLD PER 1")	USE 1 @ 2" (5A), 1 @ 22" (5B) & 1 @ 3" (5C)
6	110-217	6	WORM CLAMP (7/16" TO 1")	
7	156-729	1	S/O TEE (08H-08H-08H)	
8	111-021	1	BREATHER CAP (TANK)	
9	153-871	2	S/O COUPLER (06N-06H90, BRS)	
10	116-881	163	BULK HOSE (3/8", SOLD PER FT)	USE 1 @ 90" (10A) & 1 @ 73" (10B)
11	110-249	4	WORM CLAMP (1/4" TO 5/8")	
12	105-214	5	FLG SCREW (#10-24 X .5")	
13	106-632	2	FLG LK SCR (M12-1.75X35MM,SER)	
14	106-709	2	FLG LK NUT (M12-1.75)	
15	115-686	12	BULK EDGE (5/32",SOLD PER 1")	USE 1 @ 12"
16	217-568	1	FUEL SENDER	INCLUDES 165-704 GASKET

NOT SHOWN:

FOOTNOTES:

NOTE:

GROUND DRIVE TRACKS

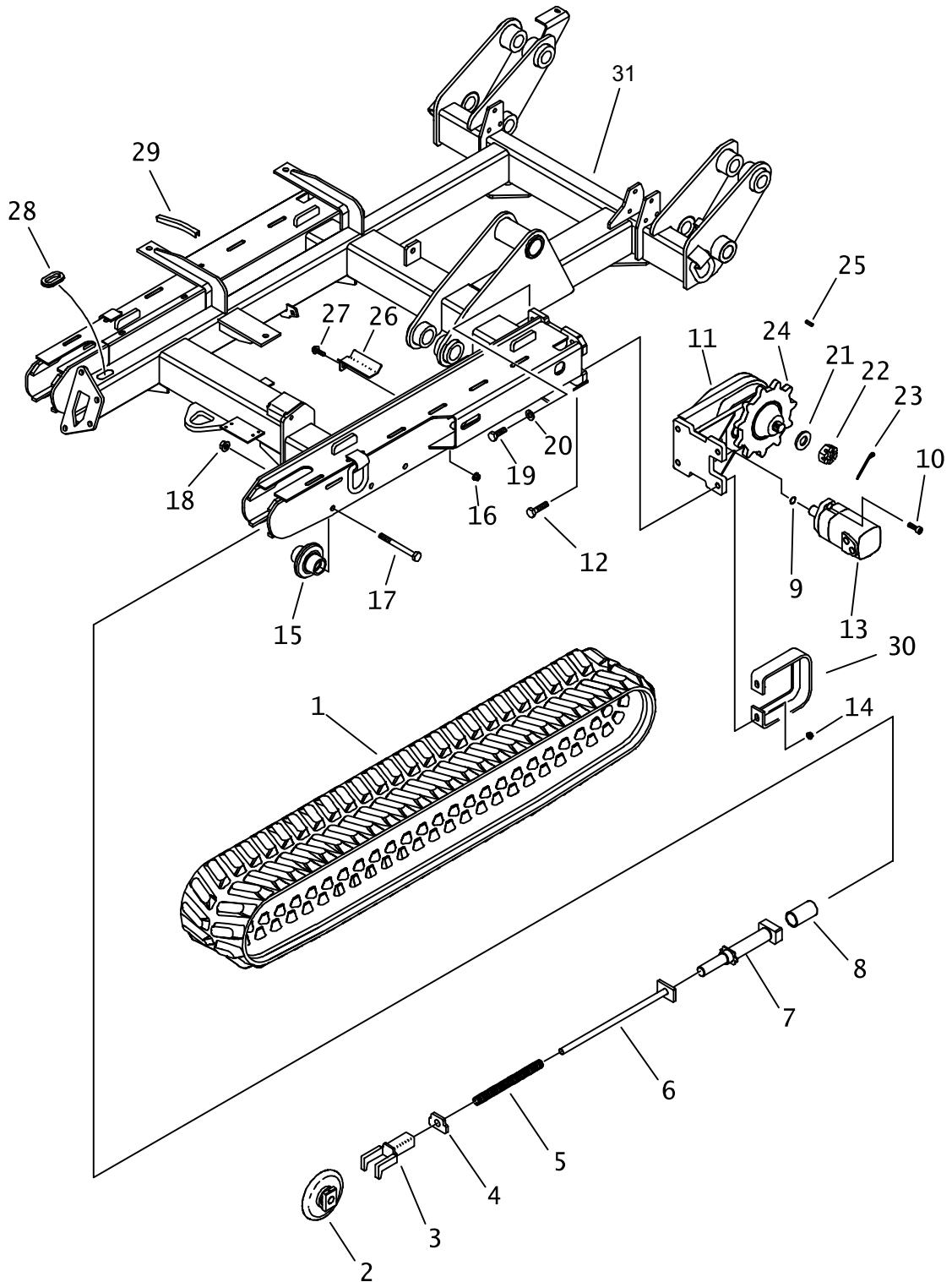

GROUND DRIVE TRACKS

REF NO.	PART NUMBER	QTY	DESCRIPTION	REMARKS
1.	315-175	2	GROUND DRIVE TRACK	
2.	170-336	2	FRONT IDLER ROLLER	
3.	353-403	2	YOKE	
4.	353-482	2	SPRING PLATE	
5.	117-122	2	COMPRESSION SPRING	
6.	353-402	2	SPACER TUBE	
7.	151-161	2	GREASE CYLINDER	
8.	353-473	2	STOP TUBE	
9.	157-099	-	O-RING (042 D70)	INCLUDED WITH 166-172
10.	106-204	4	BOLT (1/2-NC X 1-1/2", SOC)	TORQUE TO 100 FT-LB
11.	166-172	2	GEAR BOX (5.44:1)	GROUND DRIVE. Includes item 13
12.	106-341	4	SCREW (M16-2.00 X 70mm)	TORQUE TO 159 FT-LB
13.	155-581	-	HYD MOTOR	
	500-658		SEAL REPAIR KIT	
14.	106-355	4	FLG NUT (M16-2.00, 10.9)	
15.	170-335	14	IDLER ROLLER	
16.	106-709	2	FLG LOCKNUT (M12-1.75)	
17.	107-337	14	SCREW (M16-2.00 X 150mm, 10.9)	
18.	106-442	14	FLG LOCKNUT (M16-2.0, PRV TRQ)	
19.	106-340	4	SCREW (M16-2.00 x 50mm)	TORQUE TO 159 FT-LB
20.	106-392	4	WASHER (M16)	
21.	105-1352	2	WASHER (1.265)	
22.	105-917	2	CASTLE NUT (1-1/4-NF)	TORQUE TO 525-675 FT-LB
23.	105-501	2	COTTER PIN (.125" X 2.0")	
24.	174-008	2	SPROCKET (11T)	
	140-1084	2	SPROCKET (11T)	
25.	166-857	2	KEY (.437" X 1.950")	
26.	348-962	2	HOSE PROTECTOR	
27.	106-632	2	FLG LK SCREW (M12-1.75 X 35mm)	
28.	115-663	AR	GROMMET EDGE (1/4" X 12.7")	USE 6.35"
29.	116-259	AR	BULK EDGE (1/2", SOLD PER FT)	USE 7"
30.	324-456	2	TRACK SUPPORT	
31.	325-469	-	FRAME	

NOT SHOWN:

FOOTNOTES:

NOTE:

GEARBOX GROUND DRIVE

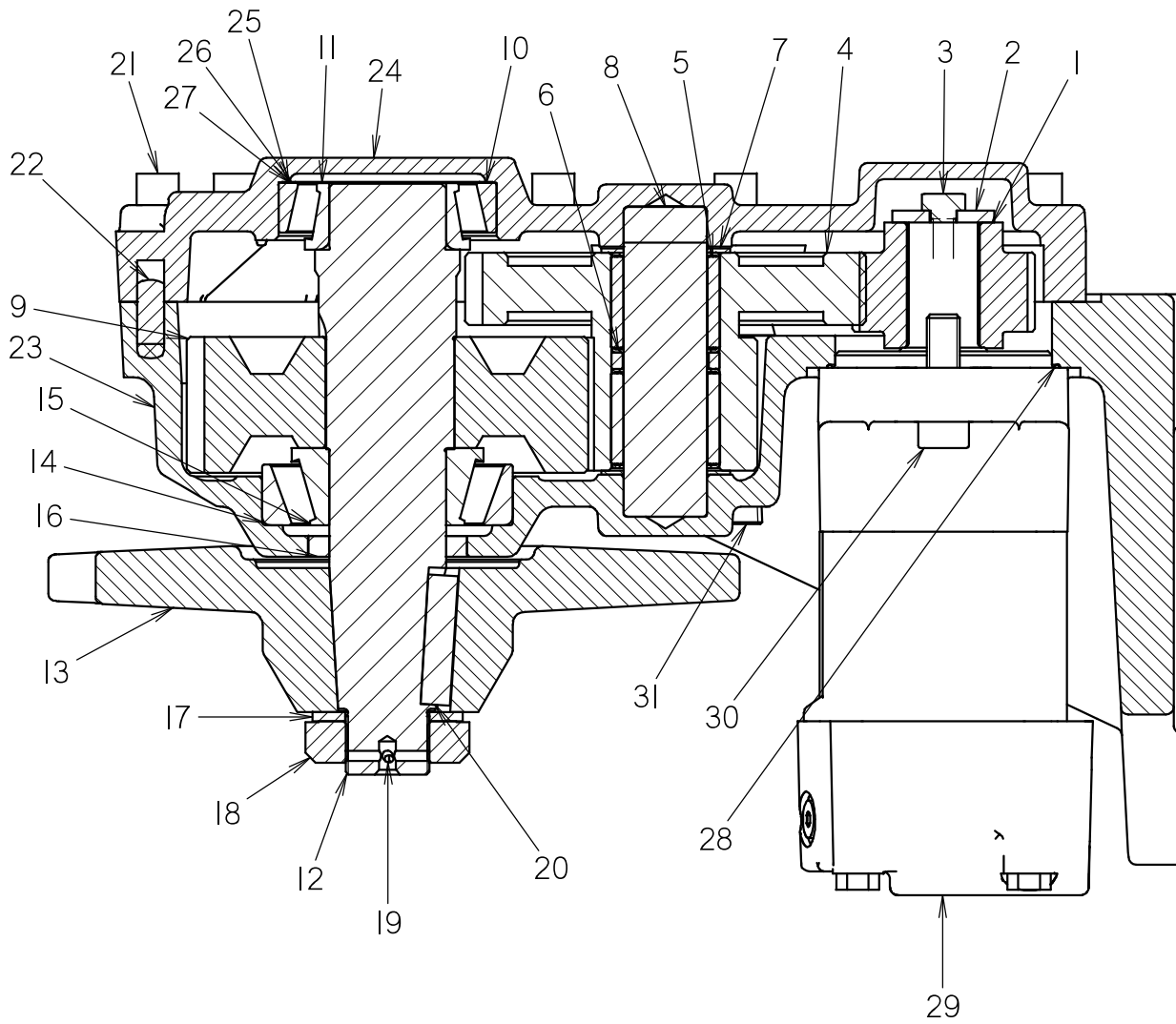

GEARBOX GROUND DRIVE

REF NO.	PART NUMBER	QTY	DESCRIPTION	REMARKS
	166-172		GEARBOX (5.44:1)	INCLUDES REF. NO'S 1-12, 14-16, 21-31
1	168-052	1	INPUT PINION	
2	105-069	1	WASHER (.406")	
3	105-024	1	LK BOLT (3/8-NC X 3/4", NLK)	TORQUE TO 45 FT-LBS
4	168-051	1	CLUSTER GEAR	
5	126-185	2	BEARING CAGE (1.50 WD)	
6	182-220	1	SPACER	
7	126-017	2	BEARING RACE (1.25")	
8	179-235	1	PIN	
9	168-053	1	OUTPUT GEAR	
10	125-270	1	TAPERED RACE (3.265")	
11	125-269	1	TAPERED BEARING (1.75")	
12	160-449	1	SHAFT	
13	140-1084	1	11 TOOTH SPROCKET	SUPERSEDES 174-008
14	125-326	1	TAPERED RACE (3.75")	
15	125-327	1	TAPERED BEARING (1.750")	
16	155-881	1	INTERNAL SEAL (1.750")	
17	105-1352	1	WASHER (1.265)	
18	105-917	1	CASTLE NUT (1-1/4-NF)	TORQUE TO 525-675 FT-LBS
19	105-501	1	COTTER PIN (1/25" X 2.0")	
20	166-857	1	KEY (.437" X 1.95")	
21	106-857	14	SCREW (M10-1.50 X 55MM, SOC)	TORQUE TO 45 FT-LBS
22	106-866	1	DOWEL PIN (M10 X 30MM)	
23	348-749	1	HOUSING (MACHINED)	
24	348-254	1	CAST COVER, MACHINED	
25	165-800	1	SHIM (.002")	AS REQUIRED
26	165-801	1	SHIM (.003")	AS REQUIRED
27	165-802	1	SHIM (.007")	AS REQUIRED
28	157-099	1	O-RING (O42 D70)	
29	155-581	1	HYD MOTOR	
30	106-204	2	BOLT (1/2 - NC X 1.50", SOC)	USE LOCTITE 271 OR EQUIVALENT, TORQUE TO 100 FT-LBS
31	115-025	4	PLUG (O8N, SQ FM, MAG)	

NOT SHOWN:

FOOTNOTES:

NOTE:

FRONT IDLER

ENDS WITH S/N: CMWSK350P60000600
ENDS WITH S/N: CMWSK650A60000427

ENDS WITH S/N: CMWSK500H60000254
ENDS WITH S/N: CMWXT850C60000125

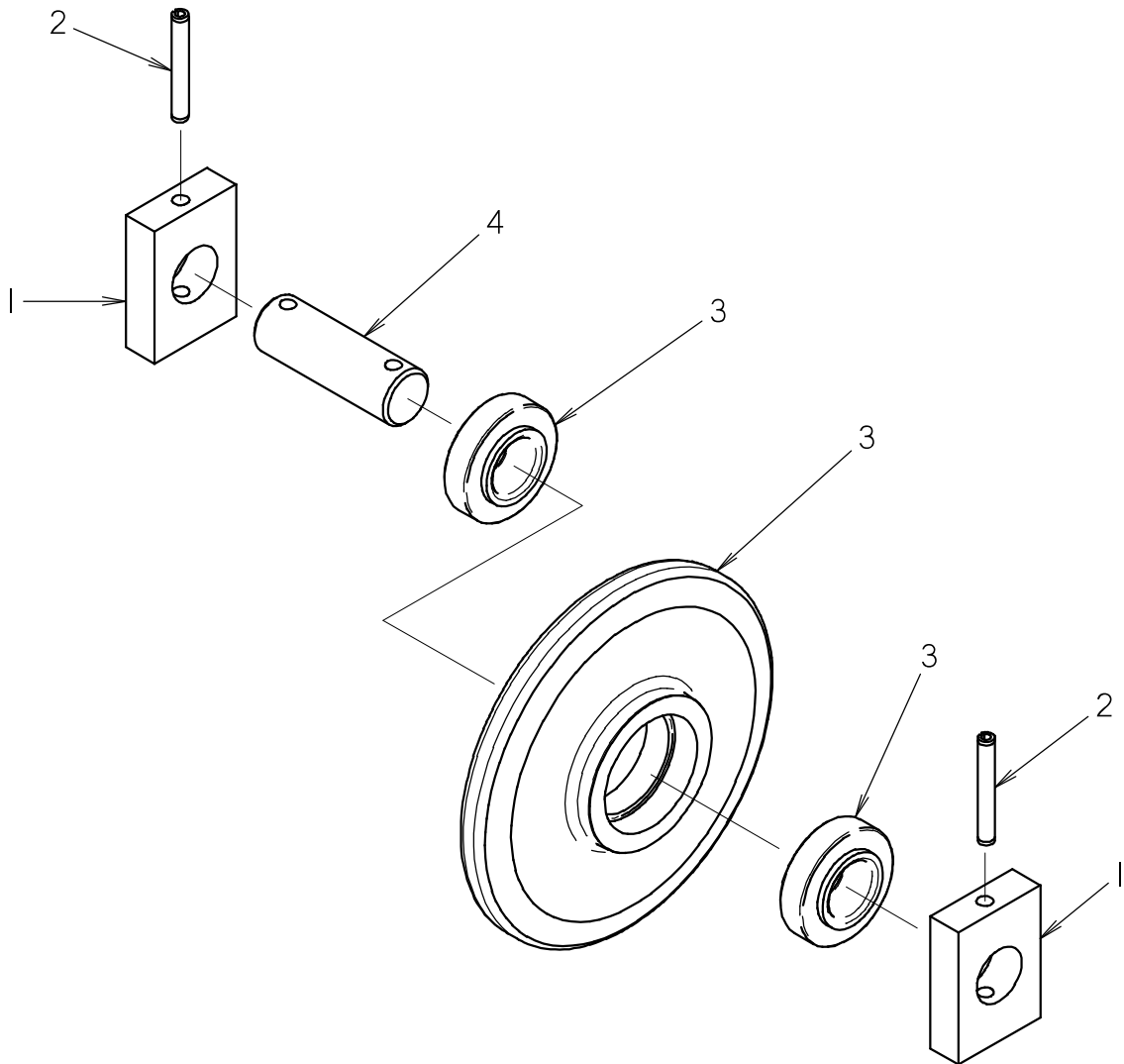

FRONT IDLER

ENDS WITH S/N: CMWSK350P60000600

ENDS WITH S/N: CMWSK500H60000254

ENDS WITH S/N: CMWSK650A60000427

ENDS WITH S/N: CMWXT850C60000125

REF NO.	PART NUMBER	QTY	DESCRIPTION	REMARKS
	I70-336	-	FRONT IDLER ROLLER	INCLUDES REF NO.'S I-4
I	353-477	2	BLOCK, PUSH	
2	I05-561	2	ROLL PIN (3/8" X 2-3/4")	
3	I70-342	1	IDLER ROLLER SUB	SEE FOOTNOTE I
4	I67-307	1	SHAFT, IDLER	

NOT SHOWN:

FOOTNOTES:

I. FOR REPLACEMENT BEARINGS, USE PART NUMBER I25-005.

NOTE:

GREASE CYLINDER

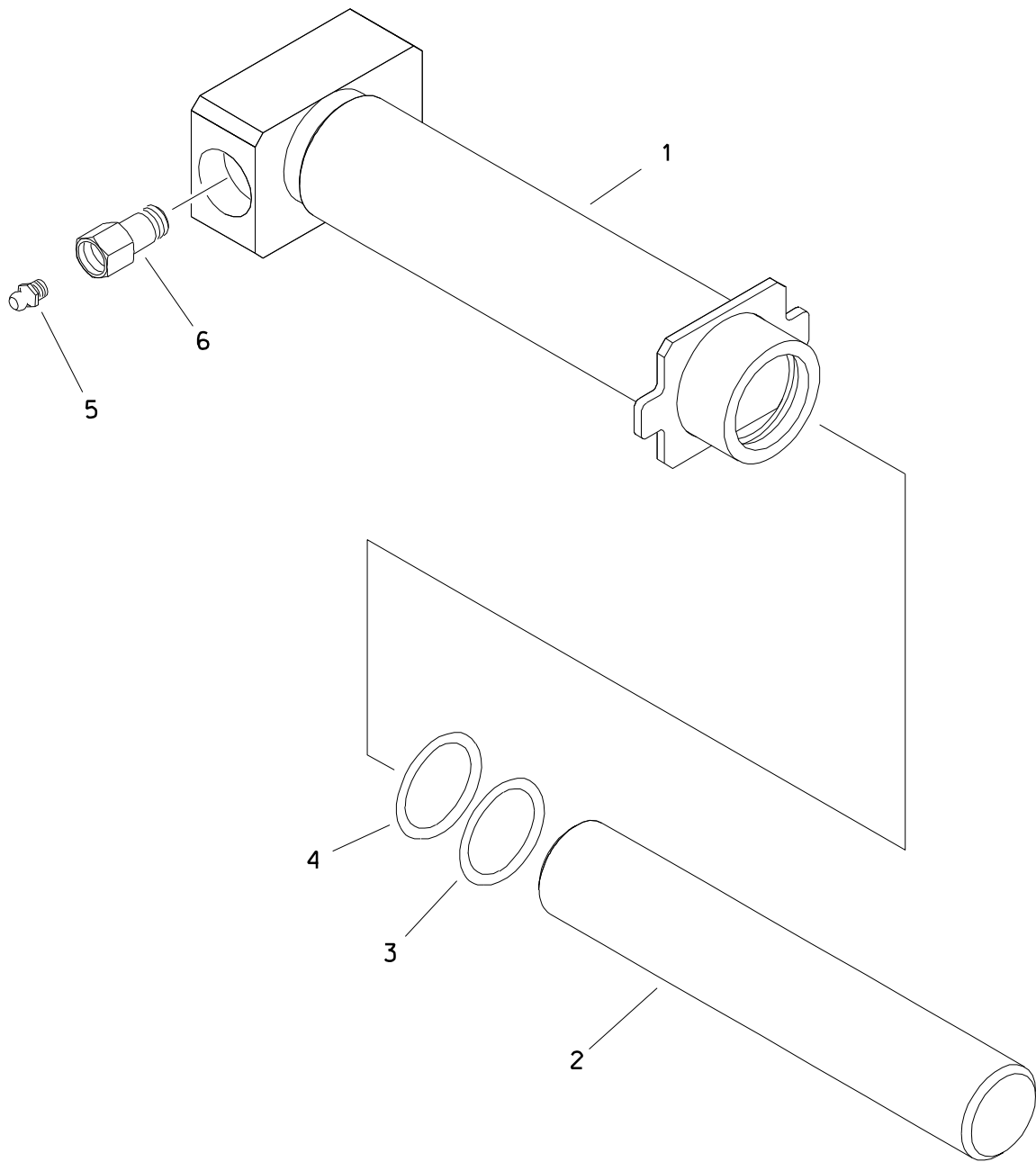

GREASE CYLINDER

REF NO.	PART NUMBER	QTY	DESCRIPTION	REMARKS
	151-161		GREASE CYLINDER	INCL REF NO.'S 1 - 4
1.	353-404	1	GREASE CYLINDER	
2.	153-501	1	CYLINDER ROD	
3.	155-732	1	BACKUP RING (224 D90)	
4.	155-704	1	O-RING (224 D70)	
5.	115-019	1	ZERK (Q2N)	
6.	159-093	1	RELIEF VALVE (5/8-NF, Q2N)	

FOOTNOTES

STABILIZER

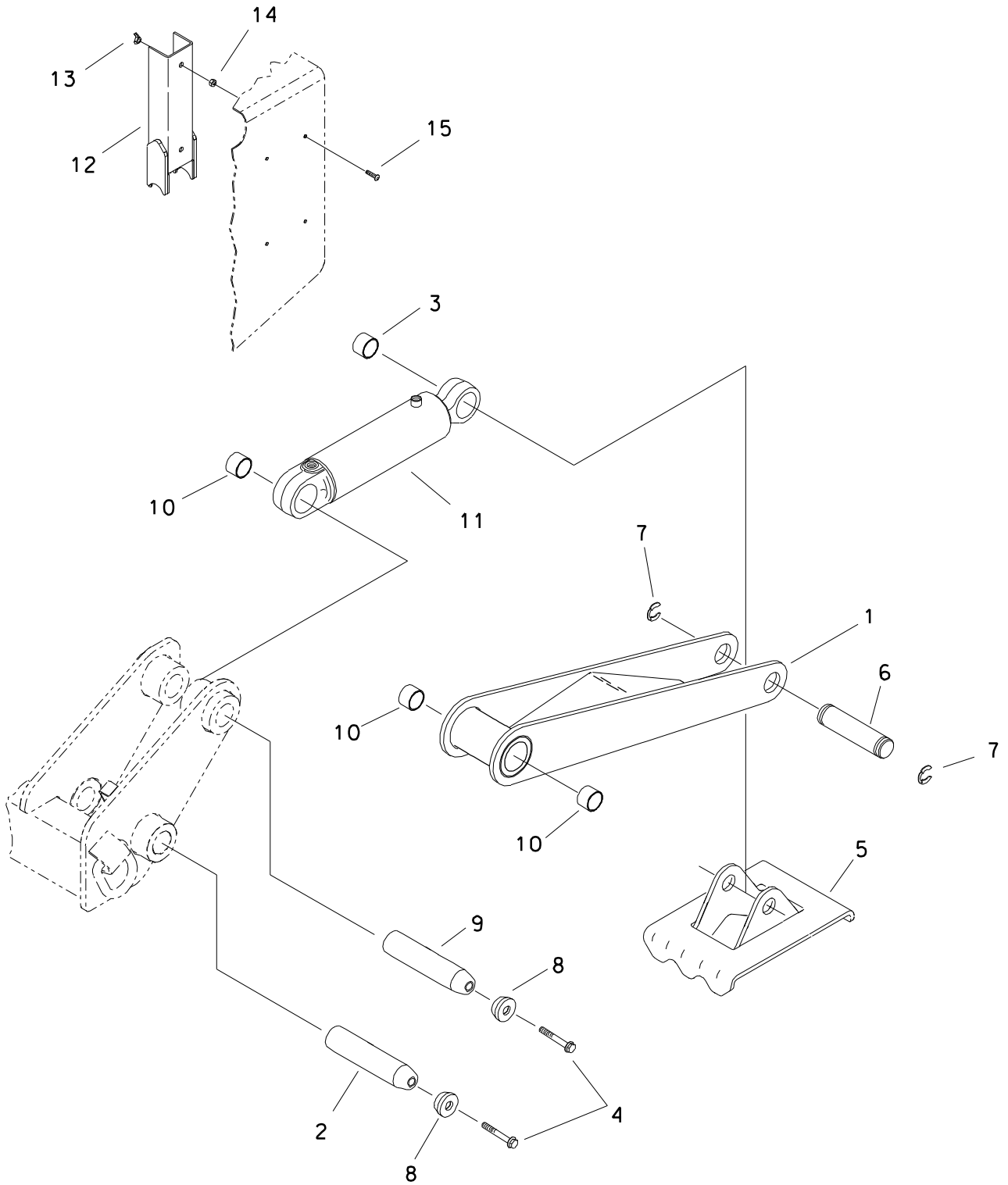

STABILIZER

REF NO.	PART NUMBER	QTY	DESCRIPTION	REMARKS
1.	316-819	2	STABILIZER ARM	
2.	183-882	2	TAPERED PIN (44.4MM X 228.6MM)	
3.	178-884	2	TENSION BUSHING (1.5")	
4.	106-470	4	FLG SCREW (M16-2.00 X 40MM)	
5.	316-880	2	STABILIZER PAD	
6.	183-209	2	BARREL PIN	
7.	115-511	4	KLIP RING (1-1/2")	
8.	181-975	4	TAPERED INSERT (1.75")	
9.	179-242	2	TAPERED PIN (44.45MM X 196MM)	
10.	125-773	6	COMPOSITION BUSHING (1.75")	
11.	151-029	2	CYL (3" X 1.5" X 10")	
12.	323-706	2	CYLINDER LOCK	
13.	195-339	4	WING NUT (1/4-NC)	
14.	105-078	4	NUT (1/4-NC)	
15.	107-304	4	SCREW (1/4-NC X 1", BUT SQC)	

FOOTNOTES

FRAME TILT

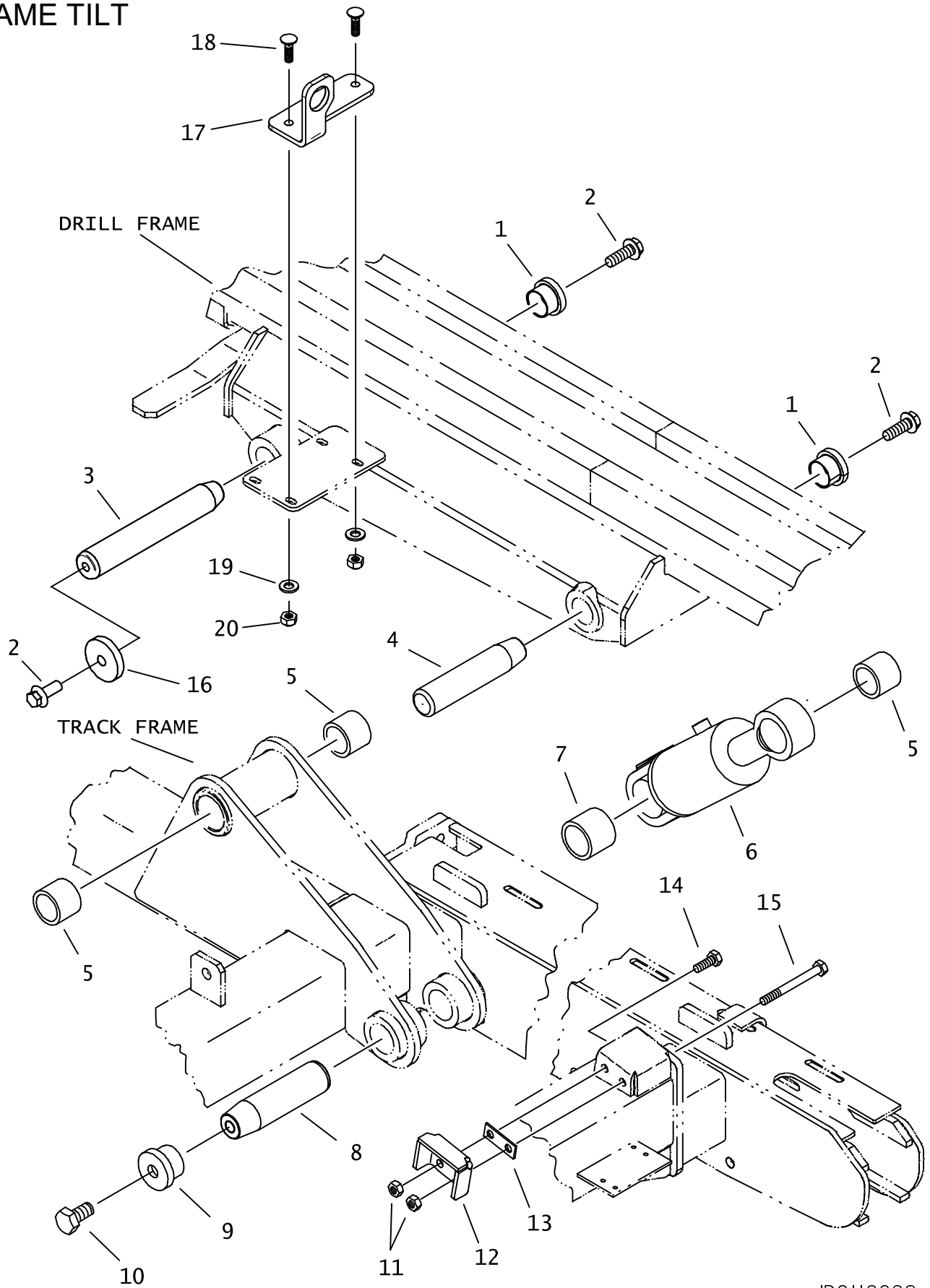

FRAME TILT

REF NO.	PART NUMBER	QTY	DESCRIPTION	REMARKS
1.	181-975	2	TAPERED INSERT (1.75")	
2.	106-470	3	FLG SCREW (M16-2.0 X 40MM)	USE #242 LOCTITE OR EQUIVALENT
3.	179-503	1	TAPERED PIN (1.75" X 10.75")	
4.	183-768	1	TAPERED PIN (44.4MM X 205MM)	
5.	125-773	3	COMPOSITION BUSHING (1.75")	
6.	151-089	1	CYL (3.5 X 1.75 X 3.0)	
7.	125-754	1	COMPOSITION BUSHING (2")	
8.	183-919	1	TAPERED PIN (50.8MM X 190MM)	
9.	184-064	1	TAPERED INSERT (2")	
10.	106-344	1	SCREW (M20-2.5 X 40MM)	
11.	106-685	2	LOCKNUT(M12-1.75, PRV TRQ,10.9)	
12.	320-169	1	FRAME STOP	
13.	320-170	AR	SHIM PLATE	
14.	105-247	1	SCREW (M12-1.75 X 35MM)	
15.	106-579	1	SCREW (M12-1.75 X 120MM)	DO NOT USE
16.	107-660	1	WASHER	
17.	327-579	1	BULKHEAD BRACKET	
18.	105-249	2	CARRIAGE BOLT	
19.	106-390	2	WASHER (M10)	
20.	105-047	2	LOCK NUT	

NOT SHOWN:

FOOTNOTES:

NOTE:

PROXIMITY SWITCHES

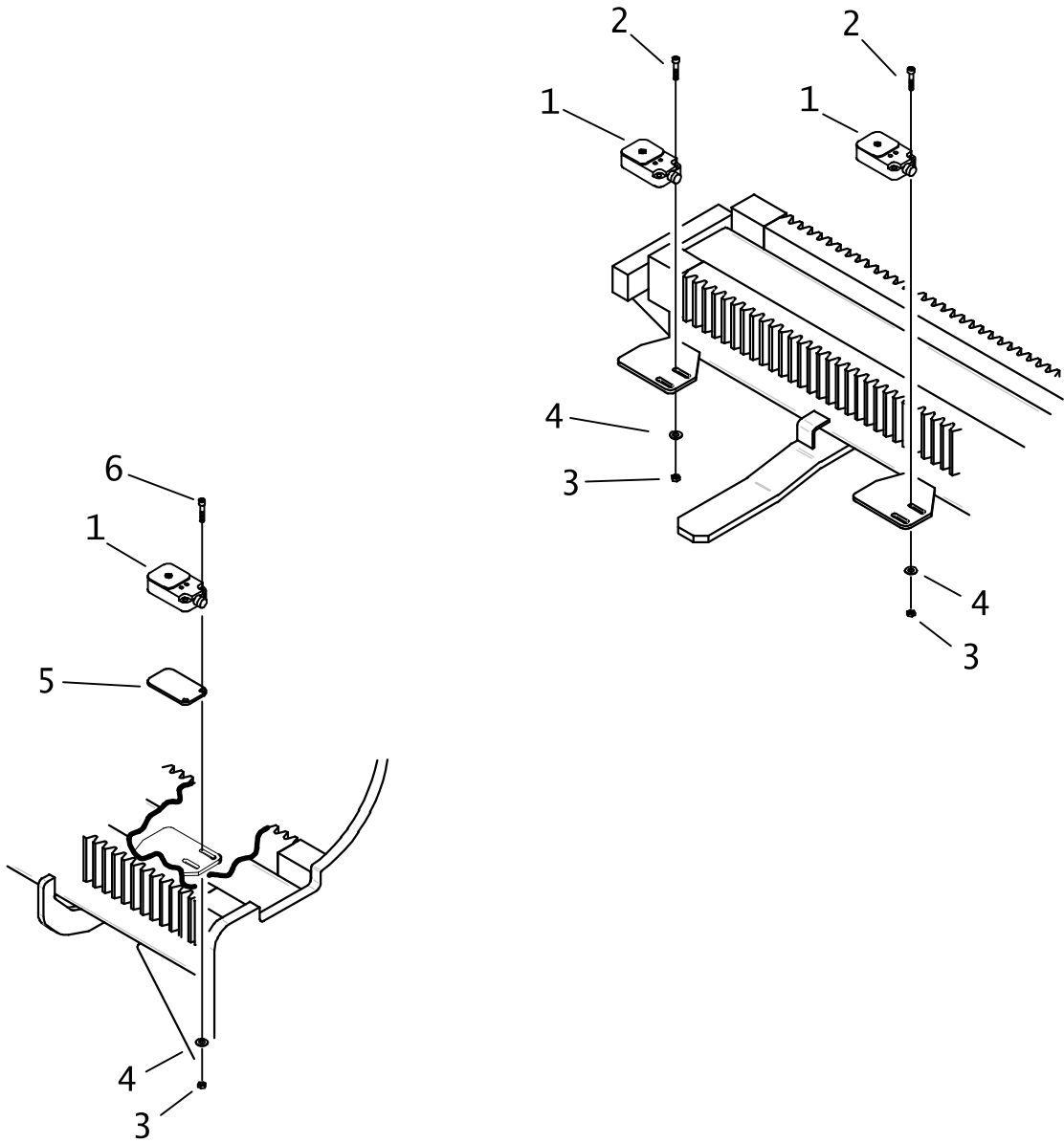

PROXIMITY SWITCHES

REF NO.	PART NUMBER	QTY	DESCRIPTION	REMARKS
1.	215-1175	3	PROXIMITY SWITCH	
2.	106-426	4	SCREW (M5-0.80 X 25MM, SOC	
3.	106-850	6	LOCKNUT (M5-0.80)	
4.	105-284	6	WASHER (3/16")	
5.	107-451	1	SHIM	
6.	107-465	2	SCREW (M5-0.80 X 30MM, SOC	

NOT SHOWN:

FOOTNOTES:

NOTE:

PROXIMITY SWITCHES DRILL PIPE

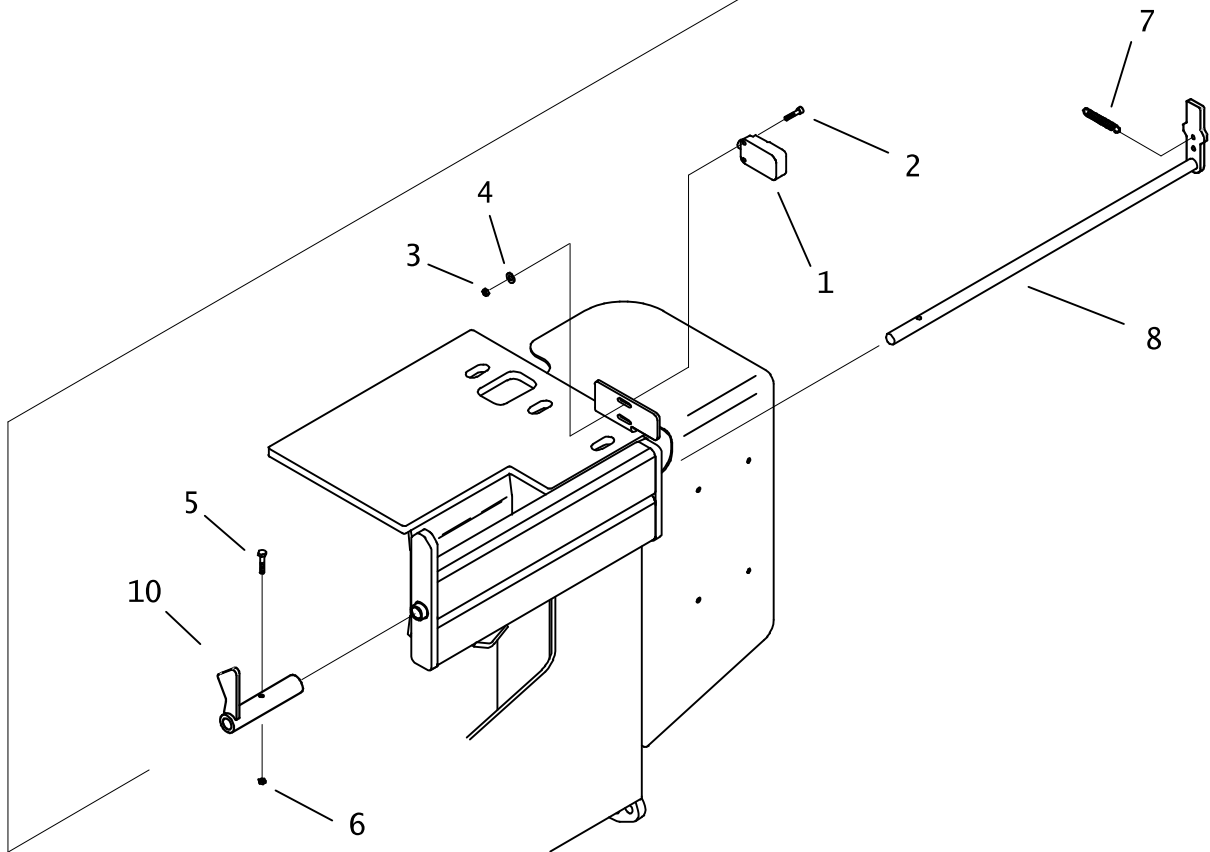
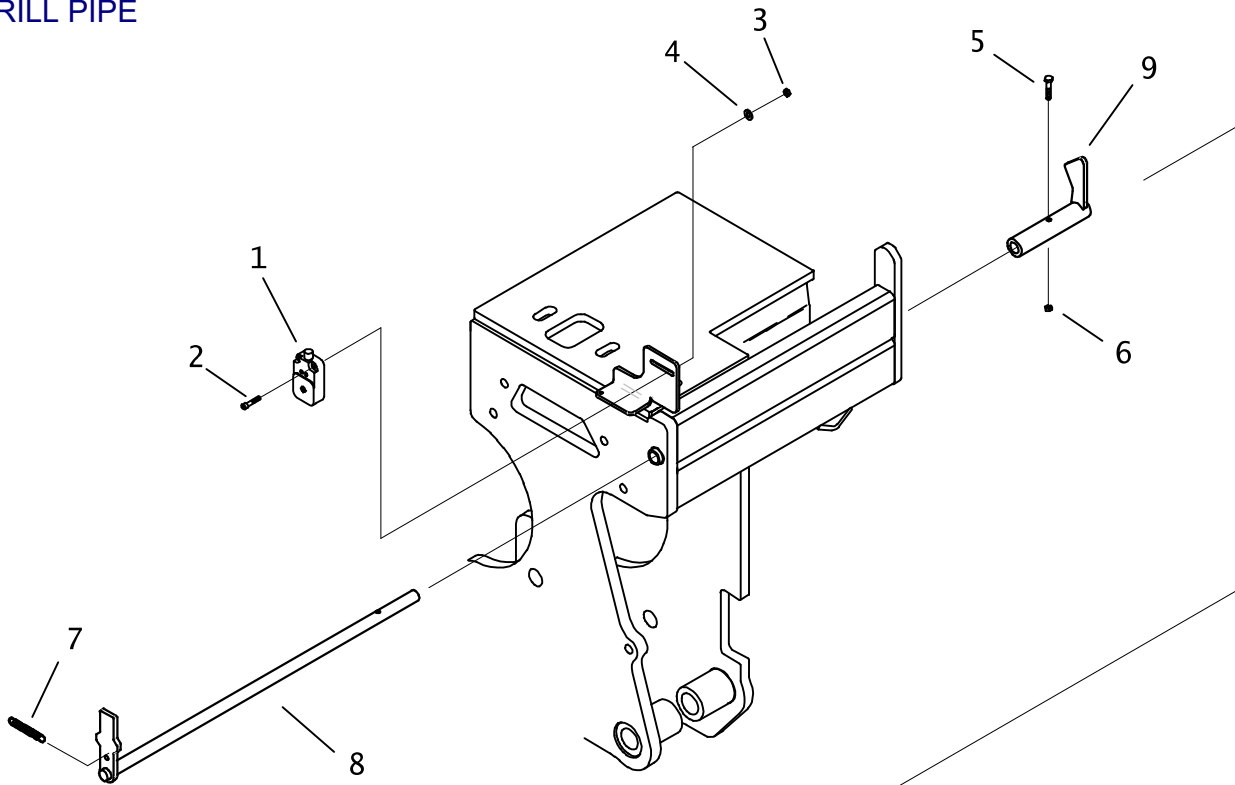

PROXIMITY SWITCHES DRILL PIPE

REF NO.	PART NUMBER	QTY	DESCRIPTION	REMARKS
1.	215-1175	2	PROXIMITY SWITCH	
2.	106-426	4	SCREW (M5-0.80 X 25MM, SOC	
3.	106-850	4	LOCKNUT (M5-0.80)	
4.	105-284	4	WASHER (3/16")	
5.	105-818	2	BOLT (1/4-NC X 1-1/2)	
6.	105-085	2	LOCKNUT (1/4-NC)	
7.	115-601	2	EXTENSION SPRING (4.062")	
8.	300-1890	2	TARGET ARM	
9.	300-1889	1	FOLLOWER ARM, FRONT	
10.	300-1888	1	FOLLOWER ARM, REAR	

NOT SHOWN:

FOOTNOTES:

NOTE:

OPERATOR'S STATION

OPERATOR SEAT

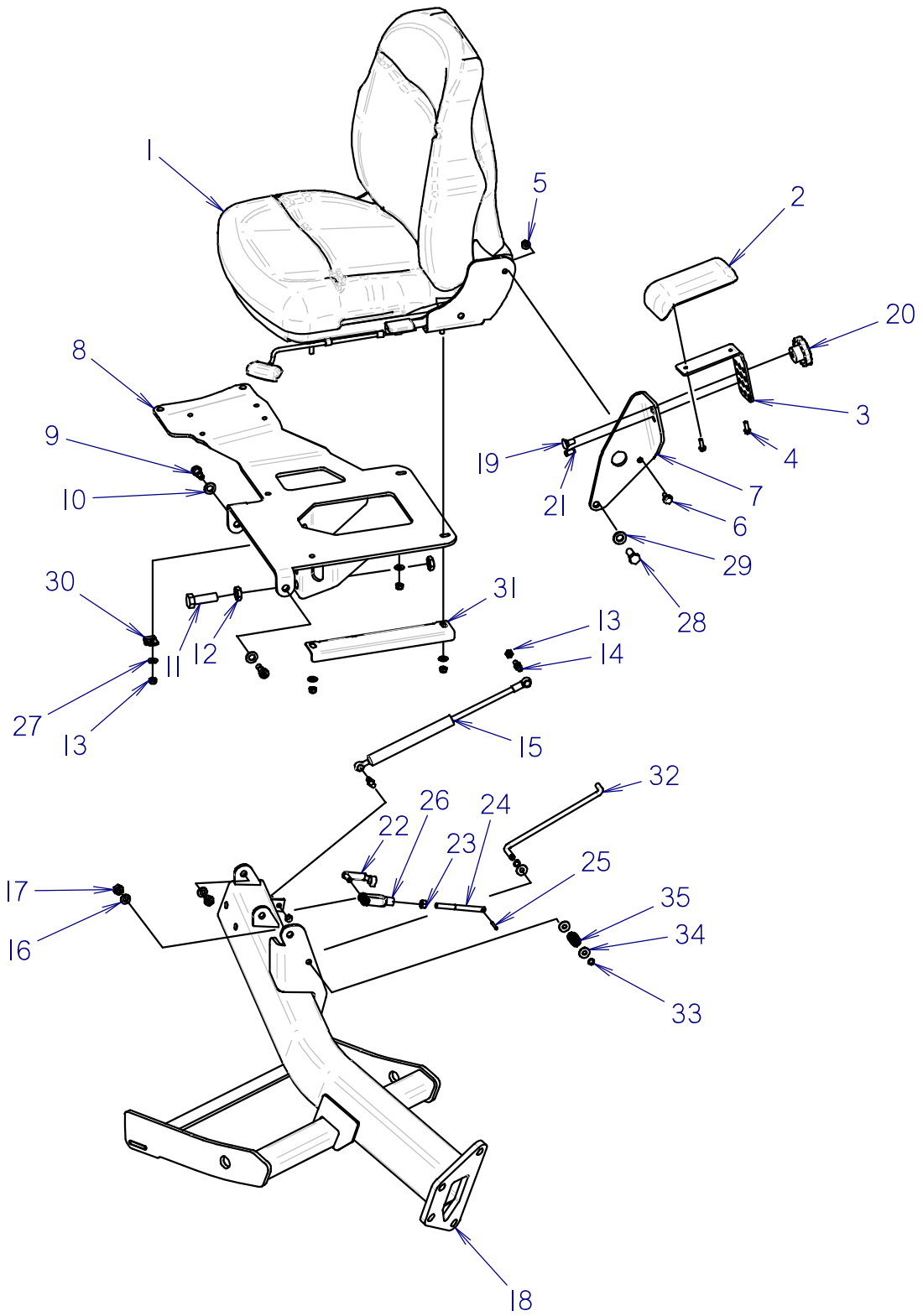

OPERATOR SEAT

REF NO.	PART NUMBER	QTY	DESCRIPTION	REMARKS
1	117-631	1	SEAT ASSEMBLY	SEE FOOTNOTE 1
2	117-314	1	ARM REST	
3	318-611	1	UPPER ARM BRACKET	
4	106-159	2	FLG SCREW (1/4-NC X 3/4")	
5	106-386	1	FLG LOCKNUT (M8-1.25)	
6	106-162	1	FLG SCREW (M8-1.25 X 20MM, GD8)	
7	324-426	1	ARMREST LOWER BRACKET	
8	316-197	1	SEAT MOUNT	
9	107-802	2	SHLD BLT (M12 X 16MM, M10-1.50)	
10	106-391	2	WASHER (M12)	
11	106-340	1	SCREW (M16-2.00 X 50MM)	
12	106-775	2	JAM NUT (M16-2.00)	
13	105-089	6	LOCKNUT (5/16-NC)	
14	110-655	2	BALL SCREW (5/16-NC X 1/2")	
15	105-694	1	STRUT (90 LB.)	
16	106-390	2	WASHER (M10)	
17	105-894	2	LOCKNUT (M10-1.50, PRV TRQ, 10.9)	
18	316-198	1	SEAT SUPPORT	
19	107-702	1	CARRIAGE BOLT (3/8-NC X 3/4")	
20	110-383	1	KNOB (3/8-NC, BLACK)	
21	108-174	1	ROLL PIN (3/8" X .750")	
22	110-286	1	SPG CLEVIS PIN (3/8" X 15/16")	
23	105-093	1	NUT (3/8-NF)	
24	179-782	1	STOP ROD	
25	105-557	1	ROLL PIN (3/16" X 1-1/8")	
26	110-027	1	CLEVIS (3/8-NF)	
27	105-095	4	WASHER (1/4")	
28	105-273	1	SCREW (M12-1.75 X 30MM)	
29	106-397	1	WASHER (M12, HARDENED)	
30	110-126	1	BOLT-ON CLAMP (1/2")	
31	179-980	1	ROD GUIDE	
32	329-049	1	PROP BAR	
33	115-477	2	GRIP RING (.375")	
34	105-117	3	WASHER (5/16")	
35	115-563	1	COMPRESSION SPRING	

FOOTNOTES

1. 117-573 BACK CUSHION; 117-912 SEAT CUSHION ASSMY W/SWITCH; 214-964 SEAT SWITCH W/BOOT; 214-965 SEAT SWITCH HARNESS

NOTE:

OPERATOR FLOOR

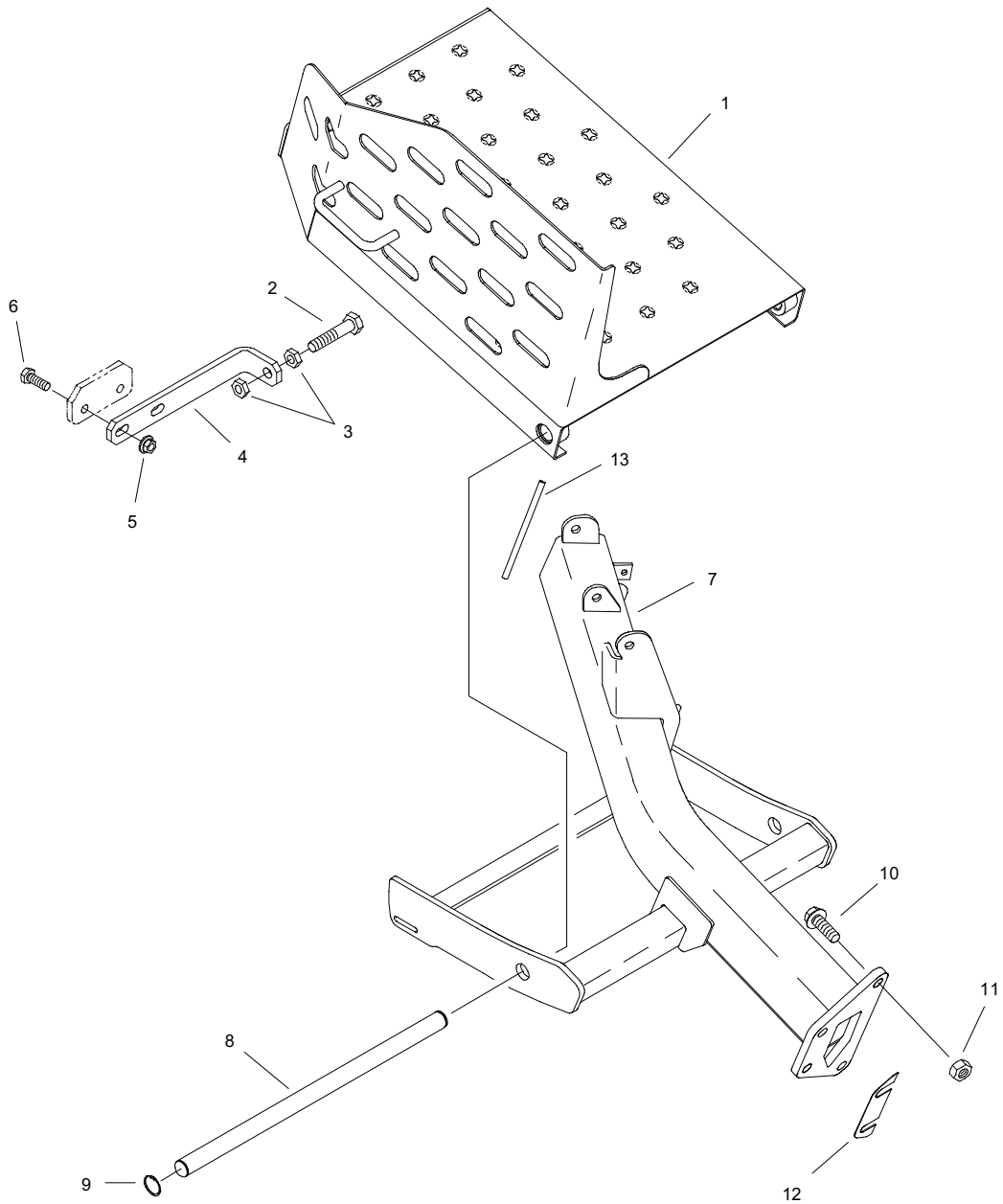

OPERATOR FLOOR

REF NO.	PART NUMBER	QTY	DESCRIPTION	REMARKS
1.	316-592	1	FLOOR	
2.	107-197	1	SCREW (M16-2.00 X 80MM,10.9)	
3.	106-775	2	JAM NUT (M16-2.00)	
4.	179-564	1	STOW BAR	
5.	106-709	2	FLG LK NUT (M12-1.75)	
6.	105-247	2	SCREW (M12-1.75 X 35MM)	
7.	316-198	1	SEAT SUPPORT	
8.	179-383	1	PIN, GROOVED	
9.	115-484	2	EXTERNAL SNAP RING (1.000")	
10.	107-336	4	FLG SCREW (M16-2.00X45MM,10.9)	
11.	106-545	4	LOCKNUT (M16-2.0,PRV TRQ,10.9)	
12.	119-008	AR	SHIM	
13.	115-704	AR	BULK EDGE (1/4", SOLD PER 1")	USE 3.5"

NOT SHOWN:

FOOTNOTES:

NOTE:

LEFT CONSOLE AND DISPLAYS

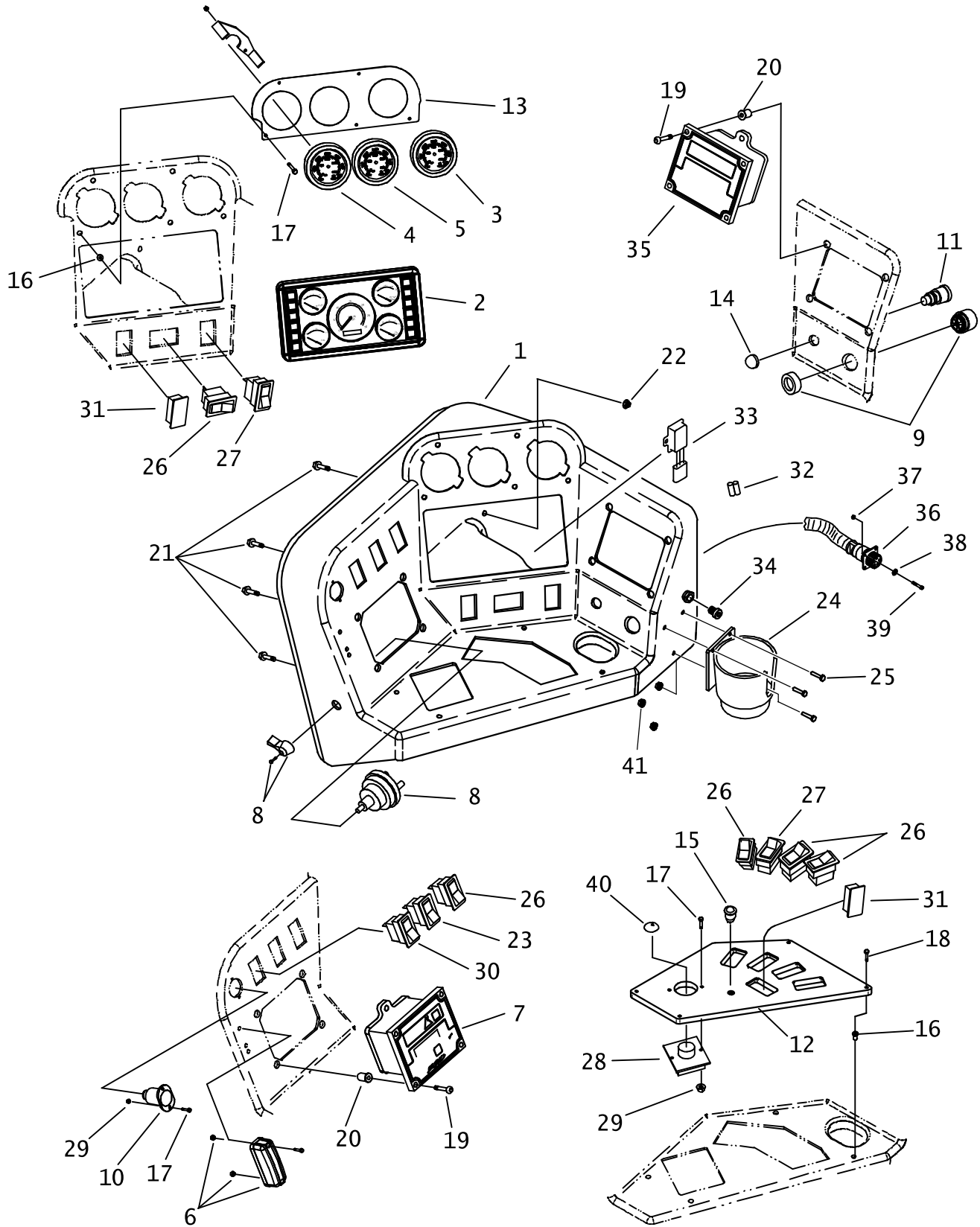

LEFT CONSOLE AND DISPLAYS

REF NO.	PART NUMBER	QTY	DESCRIPTION	REMARKS
1.	318-388	1	LEFT CONSOLE	
2.	211-096	1	GAUGE CLUSTER	
3.	258-045	1	GAUGE (4000 PSI)	
4.	150-1444	1	GAUGE (2000 PSI)	
5.	217-294	1	GAUGE (3000 PSI)	
6.	217-275	1	CONSOLE LIGHT	
7.	220-1024	1	ESID MODULE ASSEMBLY	
8.	217-819	-	BATTERY DISCONNECT SW	
9.	306-603	1	AUDIO ALARM	
10.	214-253	1	ACCESSORY SOCKET	
	214-103	1	(2-WAY) MALE CONNECTOR	
	214-104	2	PACKARD MALE TERMINAL	
	157-645	2	WEATHER-PAC SEAL (2.80MM)	
11.	306-607	1	HORN BUTTON	
12.	318-953	1	VALVE COVER PANEL	
13.	318-954	1	GAUGE PANEL	
14.	306-608	1	BUTTON COVER	
15.	214-563	1	RED LED 12V	
	211-077	-	CONNECTOR (DEUTSCH DTM04-2P)	
	211-079	-	WEDGE LOCK	
16.	107-358	9	WELLNUT (M4-0.7)	
17.	107-580	9	SCREW (M4-0.70 X 16MM, BUT SOC)	
18.	107-414	4	SCREW (M4-0.70 X 30MM, BUT SOC)	
19.	108-184	8	SCREW (M6-1.00 X 30MM, BUT SOC)	
20.	107-871	8	WELLNUT (M6-1.00 X 20.35MM LG)	
21.	106-381	7	FLG LOCK SCREW (M8-1.25 X 25MM LG)	
22.	106-386	7	FLG LOCK NUT (M8-1.25)	
23.	217-916	1	ROCKER SWITCH (DPDT) ON-OFF-ON	
24.	117-889	1	CUP HOLDER	
25.	106-556	3	SCREW (M4-0.70 X 20MM)	
26.	222-145	5	ROCKER SWITCH DPDT (ON)-ON-(ON)	
27.	217-907	2	ROCKER SWITCH (DPDT) ON-ON	
28.	214-566	1	FLUID FLOW POTENTIOMETER	
29.	105-680	4	NUT (M4, W/LK WSHR)	
30.	217-908	1	ROCKER SWITCH DPDT ON-ON-(ON)	
31.	110-962	2	FILLER PLUG	
32.	350-275	1	ALUMINUM SLEEVE (1/16")	
33.	211-277	1	1.0V-2.0V RESISTOR DIVIDER	
34.	211-078	1	CONNECTOR CAP (TURCK RS-CC)	
35.	N/A	1	90D REMOTE DISPLAY	
36.	214-415	1	90D MODULE TO RIG CABLE	
37.	105-662	4	NUT (#4-40)	
38.	106-013	3	WASHER (3/16")	
39.	107-269	4	SCREW (#4-40 X 3/4", PAN)	
40.	274-940	1	INDICATOR	
41.	105-680	3	NUT (M4, W/LK WSHR)	

FOOTNOTES:

NOTE:

VANDAL COVER

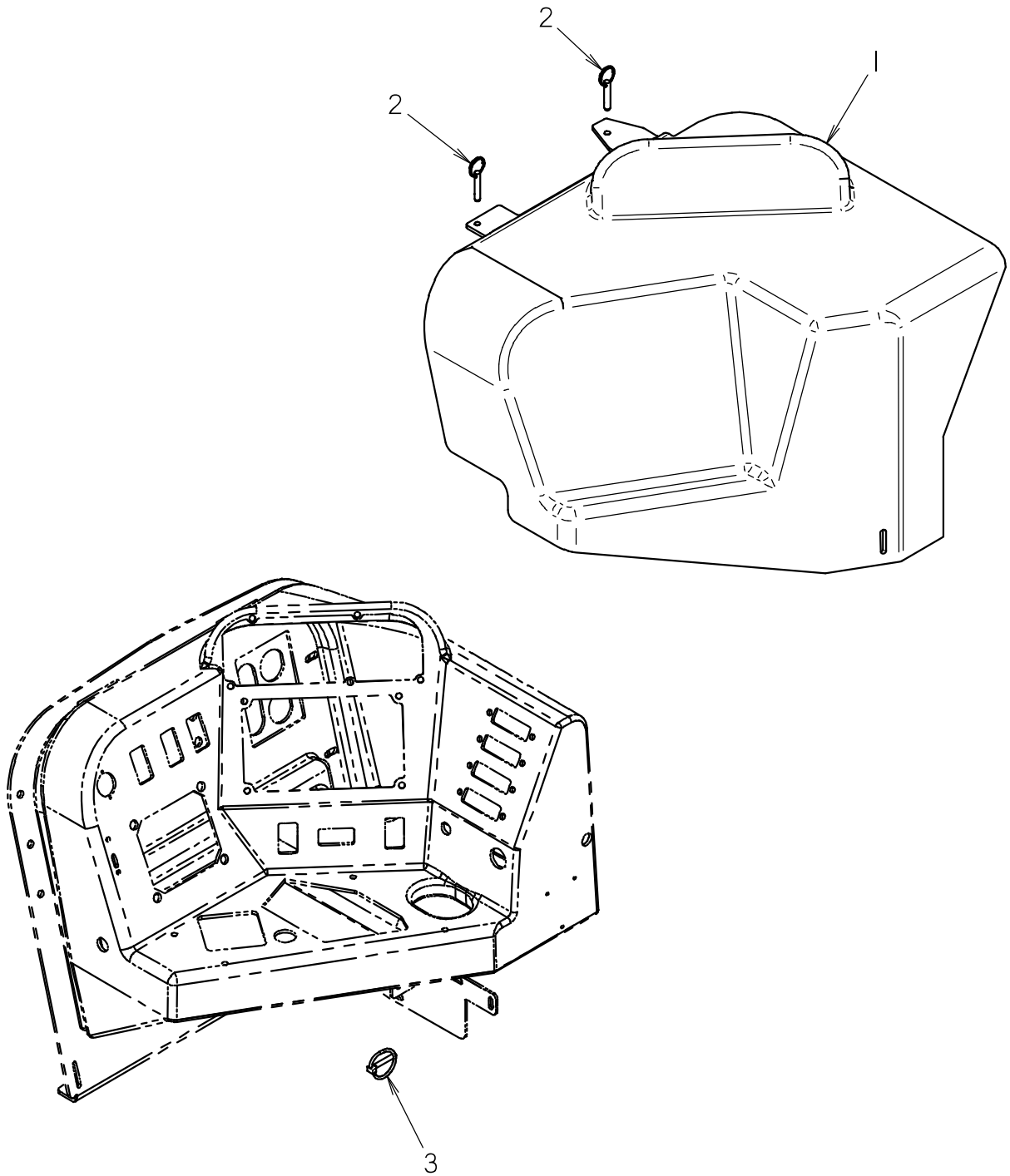

VANDAL COVER

REF NO.	PART NUMBER	QTY	DESCRIPTION	REMARKS
1	362-999	1	VANDAL COVER	
2	110-737	2	PULL PIN (5/16" X 2")	
3	105-1428	1	LYNCH PIN (1/4 X 1-9/16)	

NOT SHOWN:

FOOTNOTES:

- I. WHEN REMOVING VANDEL COVER, PLACE PINS IN MOUNT PLATE WELDED TO OUTSIDE FRAME RAIL OF ENGINE SKID, FOR SAFE STORAGE.

NOTE:

RIGHT CONSOLE AND JOYSTICK

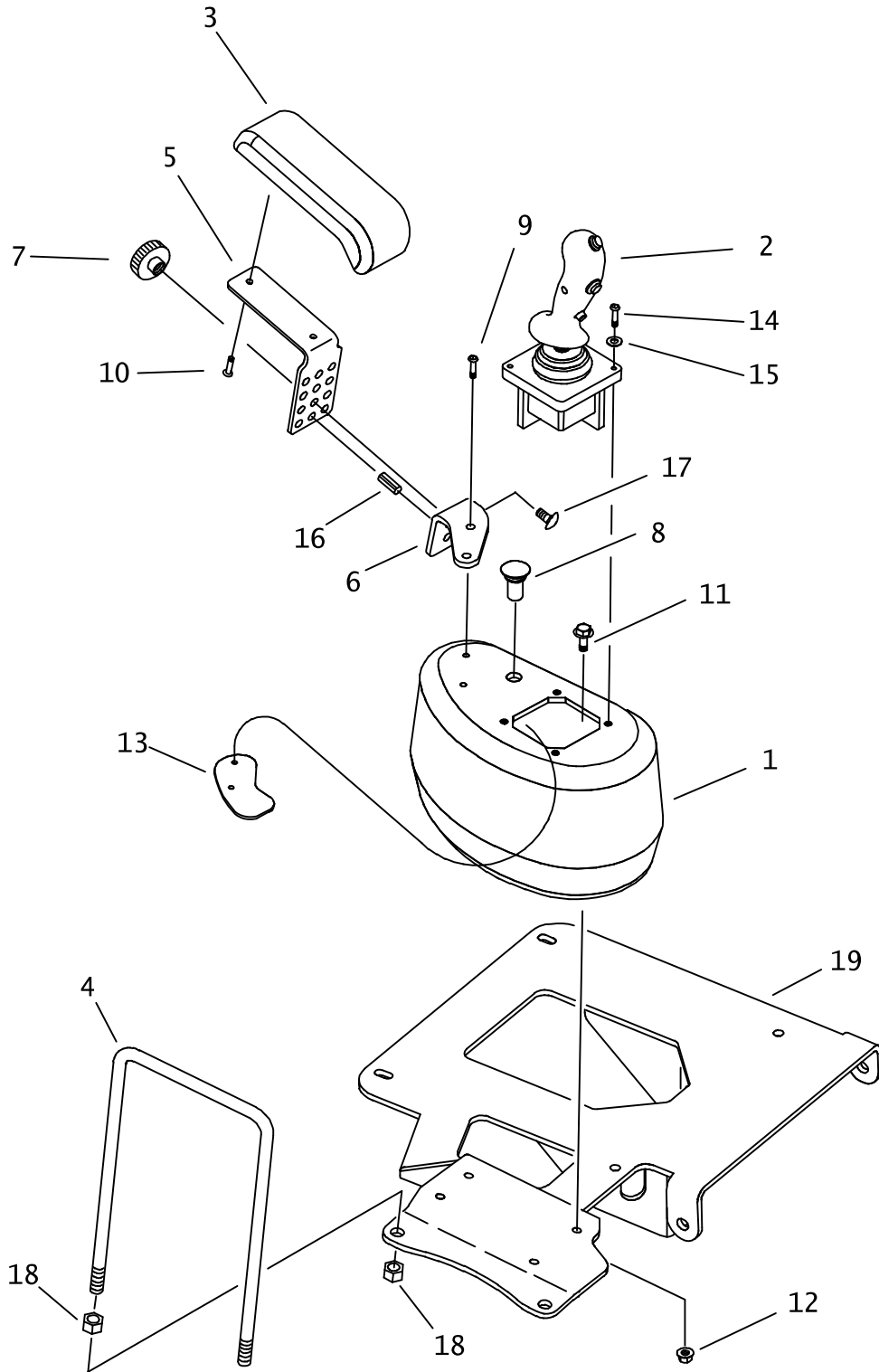

RIGHT CONSOLE AND JOYSTICK

REF NO.	PART NUMBER	QTY	DESCRIPTION	REMARKS
1.	318-389	1	RIGHT CONSOLE	
2.	215-1224	1	DUAL AXIS HALL EFFECT JOYSTICK	
3.	117-314	1	ARMREST	
4.	322-763	1	CONTROL GUARD	
5.	318-611	1	UPPER ARM BRACKET	
6.	324-425	1	LOWER ARM BRACKET	
7.	110-383	1	KNOB, 3/8 NC BLACK	
8.	217-206	1	BUTTON SWITCH (SPST)	
	214-103	1	(2-WAY) MALE CONNECTOR	
9.	107-032	2	SCREW (M8-1.25 X 20MM, BUT SOC)	
10.	106-159	2	FLG. SCREW (1/4 NC X 3/4 ")	
11.	106-162	4	FLG SCREW(M8-1.25 X 20MM, GD8)	
12.	106-386	4	FLG. LK. NUT (M8-1.25)	
13.	322-776	1	SUPPORT PLATE	
14.	106-556	4	SCREW M4-0.70 X 20MM)	
15.	106-205	4	WASHER (.191)	
16.	108-174	1	ROLL PIN (3/8" X .75")	
17.	107-702	1	CARRIAGE BOLT (3/8-NC X .75")	
18.	106-089	4	HEX NUT (M12-1.75, 10.9) ZP	
19.	316-197	-	SEAT MOUNT	

NOT SHOWN:

FOOTNOTES:

NOTE:

ELECTRICAL STRIKE SYSTEM

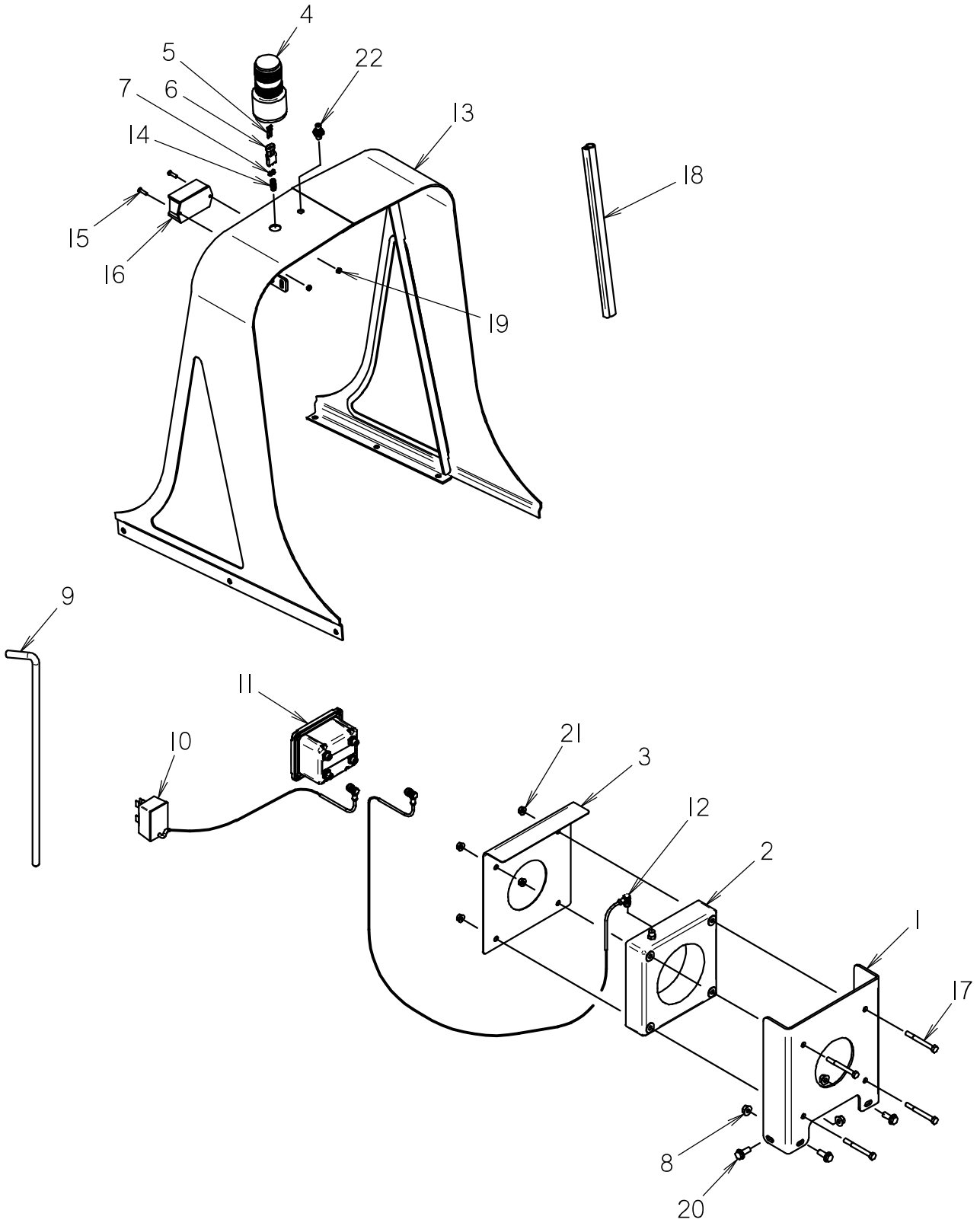

ELECTRICAL STRIKE SYSTEM

REF NO.	PART NUMBER	QTY	DESCRIPTION	REMARKS
1	300-2131	1	TRANSFORMER COVER	BEGINS WITH S/N: CMWJI220J60000130, & CMWJ2020E60000333
2	215-1081	1	CURRENT TRANSFORMER	BEGINS WITH S/N: CMWJI220J60000130, & CMWJ2020E60000333
3	300-2168	1	COVER	BEGINS WITH S/N: CMWJI220J60000130, & CMWJ2020E60000333
4	217-296	1	STROBE LIGHT (AMBER)	INCLUDES REF NO.'S 5, 6 & 7
5	214-104	2	PACKARD MALE TERMINAL	
6	214-103	1	(2-WAY) MALE CONNECTOR	
7	157-645	2	WEATHER-PAC SEAL (2.80MM)	
8	106-266	4	FLG NUT (M10-1.50)	
9	215-799	1	VOLTAGE STAKE	
10	211-042	1	VOLTAGE LIMITER CABLE	
11	220-1222	1	ESID MODULE	
12	214-554	1	CURRENT COIL CABLE	
13	300-4434	1	CENTER MOUNT	
14	216-026	1	FLEX-GUARD (25")	USE 1 @ 13"
15	106-049	2	BOLT (#10-24 X 3/4", PLPS)	
16	220-1120	1	ENGINE SENSOR AMPLIFIER MODULE	
17	106-602	4	SCREW (M8-1.25 X 80MM)	
18	116-489	1	BULK EDGE (1/8",SOLD PER FT)	USE 1 @ 22"
19	106-048	2	LOCKNUT (#10-24)	
20	106-724	4	FLG SCREW (M10-1.50 X 25MM)	
21	106-386	4	FLG LOCKNUT (M8-1.25)	
22	211-055	1	ANTENNA BULKHEAD CONNECTOR	

NOT SHOWN:

318-993 | TRANSFORMER COVER
 211-083 | CURRENT TRANSFORMER
 309-758 | COVER

ENDS WITH S/N: CMWJI220V60000129, & CMWJ2020L60000331
 ENDS WITH S/N: CMWJI220V60000129, & CMWJ2020L60000331
 ENDS WITH S/N: CMWJI220V60000129, & CMWJ2020L60000331

FOOTNOTES:

NOTE:

GROUND DRIVE CONTROL

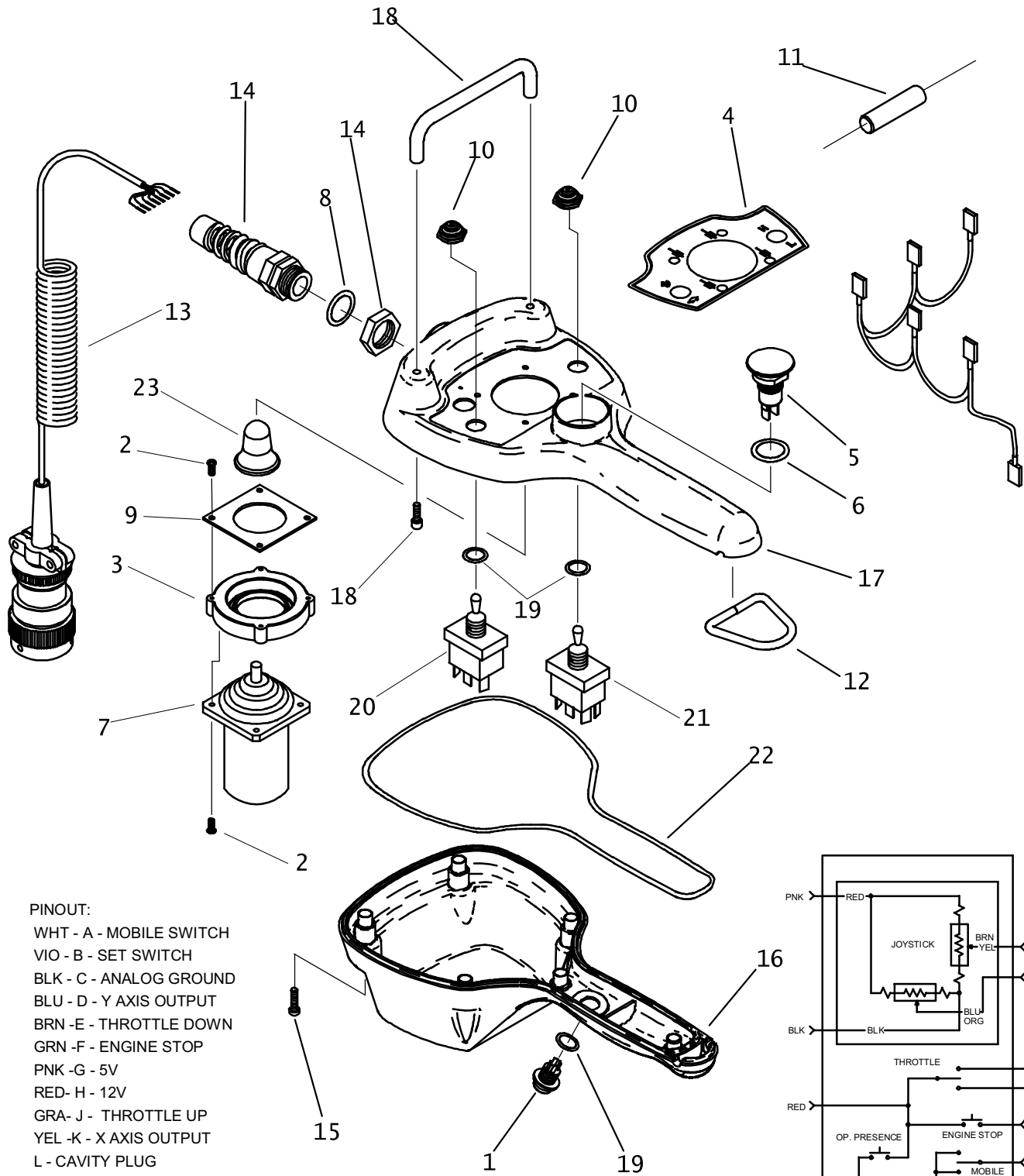

PINOUT:

- WHT - A - MOBILE SWITCH
- VIO - B - SET SWITCH
- BLK - C - ANALOG GROUND
- BLU - D - Y AXIS OUTPUT
- BRN - E - THROTTLE DOWN
- GRN - F - ENGINE STOP
- PNK - G - 5V
- RED - H - 12V
- GRA - J - THROTTLE UP
- YEL - K - X AXIS OUTPUT
- L - CAVITY PLUG
- M - CAVITY PLUG
- N - CAVITY PLUG
- P - CAVITY PLUG

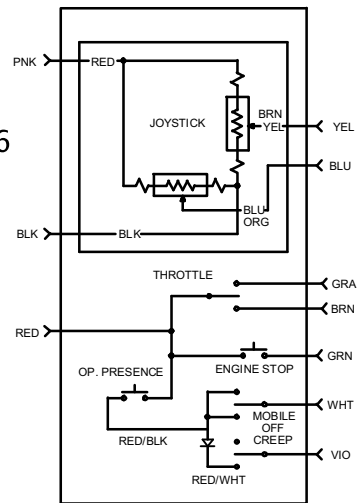

GROUND DRIVE CONTROL

REF NO.	PART NUMBER	QTY	DESCRIPTION	REMARKS
	214-589		GROUND DRIVE CONTROL	
1.	214-614	1	PUSH BUTTON SWITCH (SPST) OFF-ON	
2.	106-820	8	SCREW, SELF TAPPING (3.0 X 12MM)	
3.	305-664	1	JOY STICK ADAPTER	
4.	274-998	1	DECAL	
5.	214-615	1	KILL SWITCH	
6.	157-040	1	O-RING (-016 D90)	
7.	214-613	1	JOYSTI K ASSEMBLY	SEE FOOTNOTE 1
	215-1394	1	JOYSTICK ASSEMBLY	SEE FOOTNOTE 1
8.	157-017	1	O-RING (.018 D90)	
9.	149-558	1	JOYSTICK GASKET	
10.	214-728	2	TOGGLE SWITCH HALF BOOT (SEAL)	
11.	215-1720	1	DIODE IN5402	
12.	105-775	1	D-RING	
13.	211-020	1	COILED CORD-MALE	
14.	211-021	1	STRAIN RELIEF	
15.	106-876	6	SCREW	
16.	214-497	1	LOWER HOUSING	
17.	214-498	1	UPPER HOUSING	
18.	116-933	1	HANDLE	
	106-894	2	SCREW (#8-32 X 1" PLPS SSI)	SEE FOOTNOTE 2
19.	157-039	2	O-RING (-014 D90)	
20.	217-896	1	TOGGLE SWITCH	
21.	214-570	1	TOGGLE SWITCH (DPDT) ON-OFF-ON	
22.	116-549	AR	ROPE GASKET (USE 27")	
23.	116-932	1	JOYSTICK KNOB	

NOT SHOWN:

FOOTNOTES:

- I. JOYSTICK SHOULD BE ORIENTED WITH LABEL POINTING TOWARDS CABLE END. (REV G)
- I. JOYSTICK SHOULD BE ORIENTED WITH X+ ON LABEL POINTING TOWARDS CABLE END. (REV H)
Y-AXIS OUTPUT: 3.75V FORWARD 1.25V BACK
X-AXIS OUTPUT: 3.75V LEFT 1.25V RIGHT

2. APPLY THREAD LOCKING COMPOUND TO BOTH HANDLE SCREWS.

NOTE:

NOTES:

HYDRAULICS

FILTER AND RESERVOIR HYDRAULICS

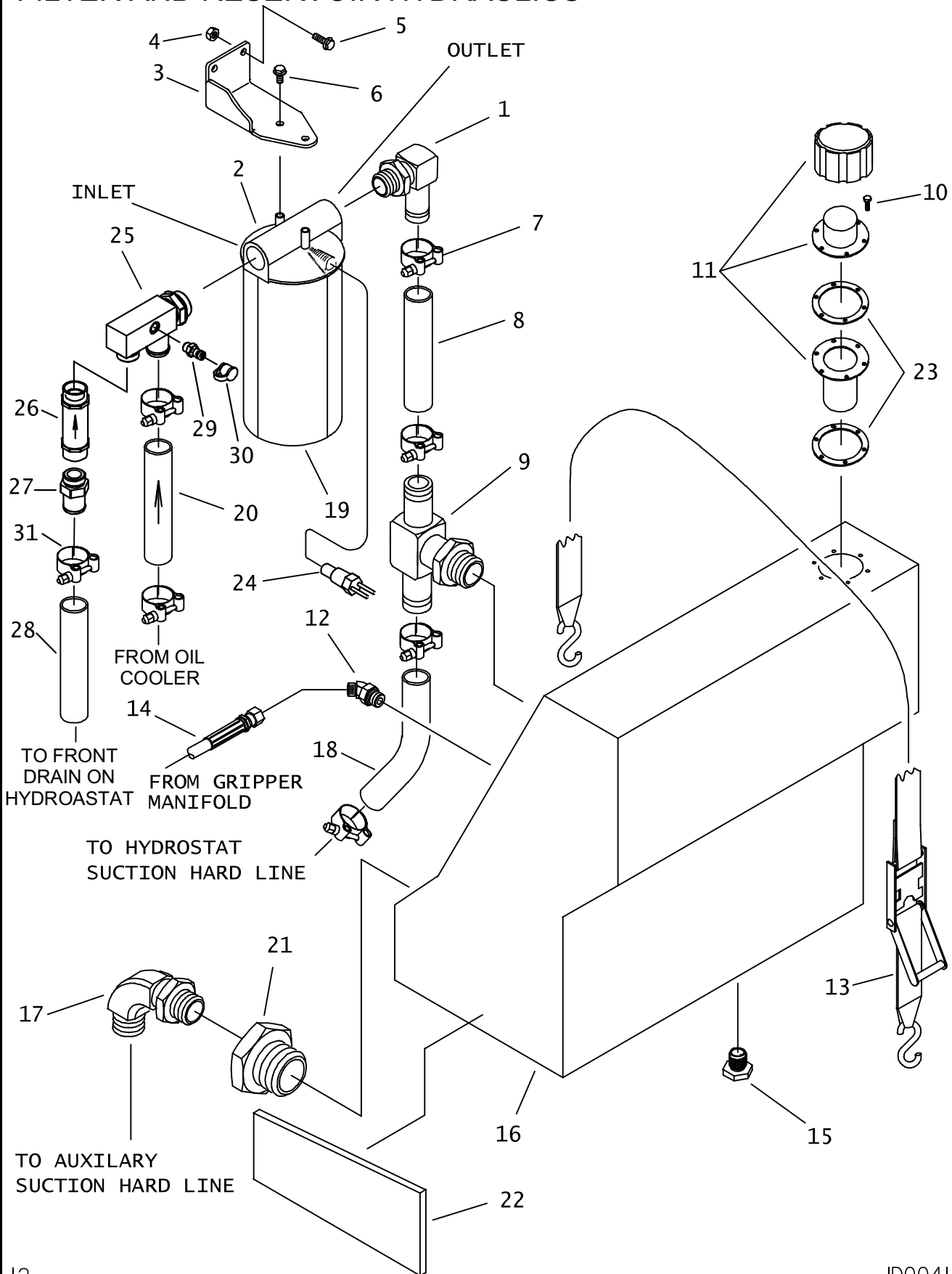

FILTER AND RESERVOIR HYDRAULICS

REF NO.	PART NUMBER	QTY	DESCRIPTION	REMARKS
1.	155-168	1	S/O COUPLER (20S-20H90)	
2.	157-458	1	FILTER HEAD	
	500-1613		OIL TEMP INDICATOR	
3.	318-610	1	OIL FILTER BRACKET	
4.	107-096	2	LOCKNUT (M8-1.25 NLK)	
5.	106-162	2	FLG SCREW(M8-1.25 X 20MM, GD8)	
6.	105-823	2	FLG LK BOLT (5/16-NC X 3/4")	
7.	149-342	7	T-BOLT CLAMP (1.69" TO 2.50")	
8.	116-587	AR	BULK HOSE (11/4", SOLD PER 1")	USE 1 @ 18.5"
9.	514-164	1	S/O BR TEE (20S-20H-20H)	
10.	105-214	6	HEX SCREW (#10-24 X 5/8")	
11.	110-008	1	FILLER BREATHER (2-1/8")	
12.	154-225	1	CONNECTOR (060-08S45)	
13.	118-181	1	RATCHET STRAP (1"X6")	
14.	154-798	-	HOSE (060FX-62"-3000)	
15.	500-302	1	PLUG (-12S)	
16.	364-641	1	HYDRAULIC RESERVOIR	
17.	514-095	1	CONNECTOR (20S-20090)	
18.	116-587	AR	BULK HOSE (11/4", SOLD PER 1")	USE 1 @ 14"
19.	153-792	1	FILTER ELEMENT	
20.	116-587	AR	BULK HOSE (11/4", SOLD PER 1")	USE 1 @ 25"
21.	514-446	1	REDUCER (24S-20SF)	
22.	118-180	2	TANK SPACER	
23.	165-626	2	FILLER NECK GASKET	
24.	214-854	1	TEMPERATURE SWITCH	
25.	158-249	1	SPECIAL 90(20S-20H-16S-06SF)	
26.	158-248	1	CHECK VALVE (16SF-16SF,20 PSI)	
27.	155-211	1	S/O COUPLER (16S-12H)	
28.	116-636	AR	BULK HOSE (3/4" SOLD PER FT)	USE 1 @ 85"
29.	159-147	1	QDC ADAPTER (02-06S)	
30.	159-148	1	DUST CAP (1/8")	
31.	110-353	1	WORM CLAMP (3/4" TO 1-1/2")	

NOT SHOWN:

FOOTNOTES:

NOTE:

HYDRAULIC OIL COOLER

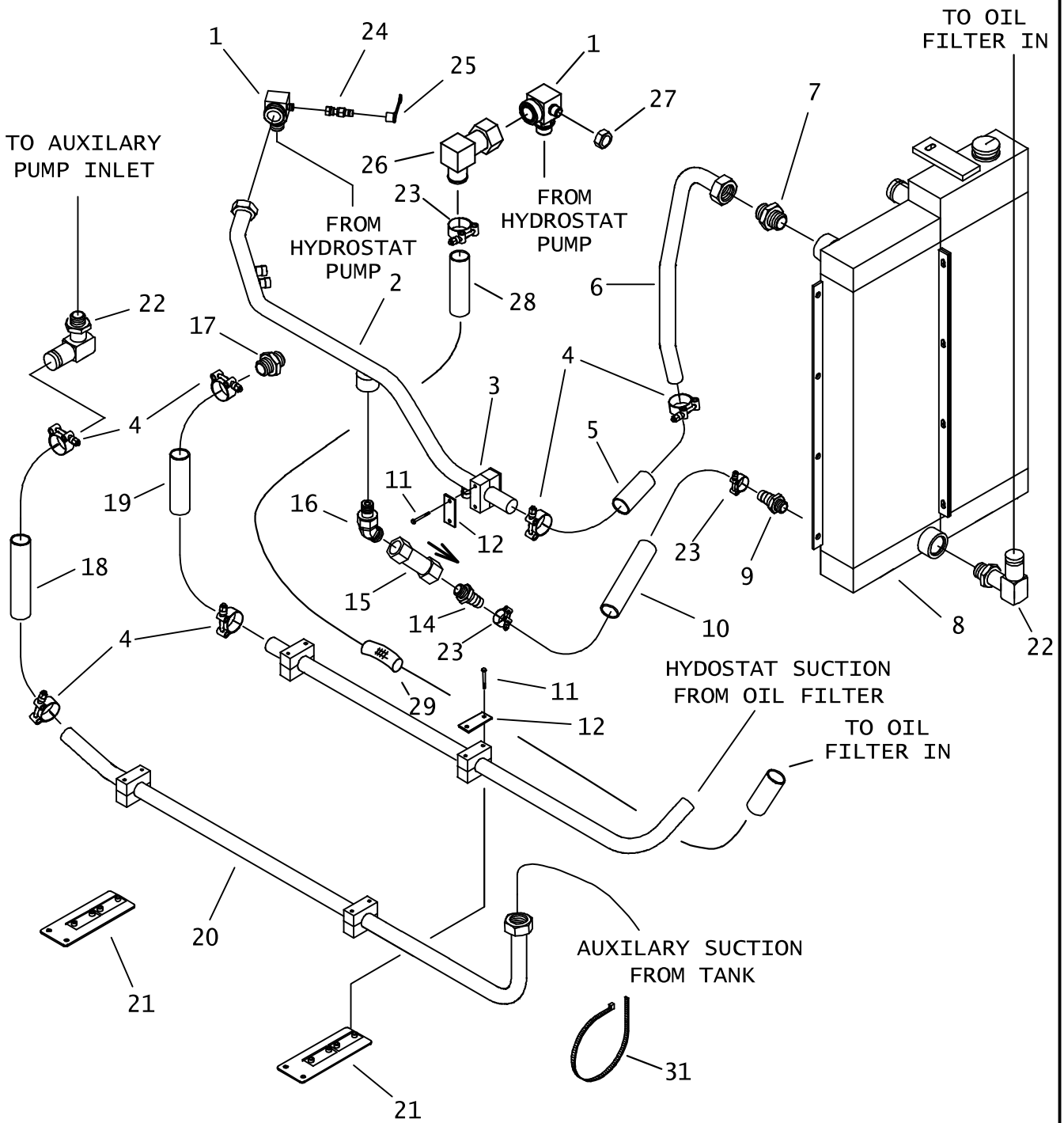

HYDRAULIC OIL COOLER

REF NO.	PART NUMBER	QTY	DESCRIPTION	REMARKS
1.	157-768	2	CONNECTOR (12S-200-060)	
2.	157-254	1	HYD LINE	
3.	111-026	1	BOLT-ON CLAMP (1-1/4", PAIR)	
4.	149-342	7	T-BOLT CLAMP (1.687"-1.50")	
5.	116-587	AR	BULK HOSE (1-1/4", SOLD PER FT)	USE 1 @ 13"
6.	157-472	1	HYD LINE (-20)	
7.	514-097	1	CONNECTOR (20S-200)	
8.	194-229	-	RADIATOR/HOT OIL COOLER	
9.	155-191	1	S/O COUPLER (10S-12H)	
10.	116-636	AR	BULK HOSE (3/4", SOLD PER FT)	USE 1 @ 26"
11.	105-224	2	BOLT (1/4-NC X 2-1/2")	
12.	322-362	1	BACKUP SPACER	
13.	157-253	1	HYD LINE	
14.	155-046	1	COUPLER (12S-12H)	
15.	158-576	1	CHECK VALVE (12SF-12SF)	
16.	154-251	1	CONNECTOR (12S-12045)	
17.	155-004	1	S/O COUPLER (20S-20H)	
18.	116-587	AR	BULK HOSE (1-1/4", SOLD PER FT)	USE 1 @ 23"
19.	116-587	AR	BULK HOSE (1-1/4", SOLD PER FT)	USE 1 @ 17"
20.	157-252	1	HYD LINE	
21.	327-728	1	CLAMP PLATE	
22.	155-168	2	S/O COUPLER (20S-20H90)	
23.	110-353	2	WORM CLAMP (3/4" TO 1-1/2")	
24.	159-157	1	QDC ADAPTER (02-060F)	
25.	159-148	-	DUST CAP (1/8")	
26.	157-260	1	ELBOW (20H-200FX90, SPECIAL)	
27.	154-326	1	CAP (060F)	
28.	116-587	AR	1-1/4" BULK HOSE, SOLD PER FOOT	
29.	105-570	2	ROLL PIN (M12 X 100MM)	
30.	106-386	2	FLG LOCKNUT (M8-1.25)	
31.	110-031	5	CABLE TIE (1/2") 20" LONG	
32.	110-339	4	BOLT-ON CLAMP (1-1/4")	
33.	324-226	2	BACKUP SPACER	

FOOTNOTES

NOTE:

ROTATION HYDRAULICS

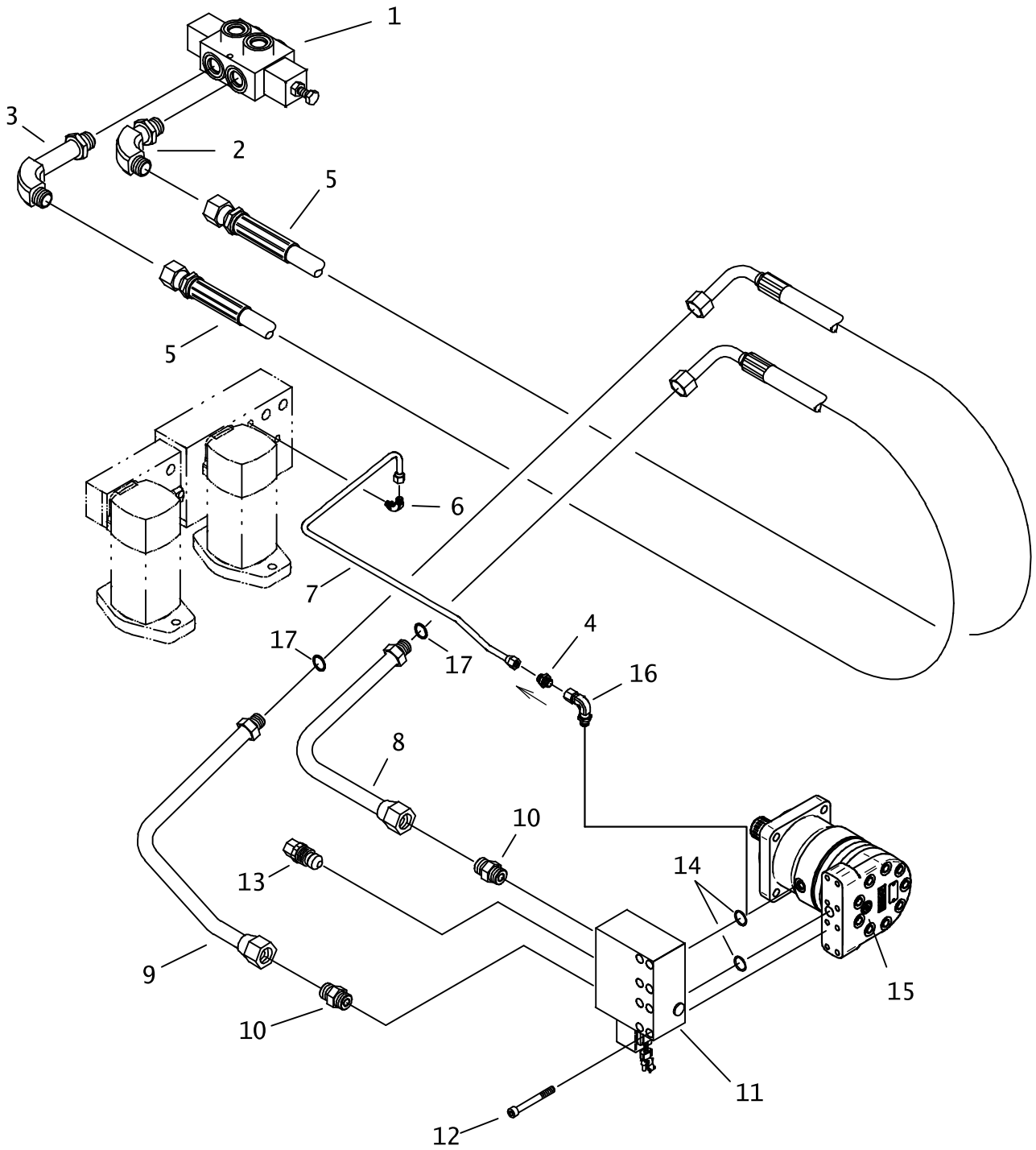

ROTATION HYDRAULICS

REF NO.	PART NUMBER	QTY	DESCRIPTION	REMARKS
1.	159-912	-	HYD CONTROL VALVE	
	191-396	-	SEAL KIT	
	500-1942	-	SEAL WASHER	
2.	154-270	1	CONNECTOR (12S-12090)	
3.	154-338	1	CONNECTOR (12S-12090, XL)	
4.	159-750	1	FLOW CHECK VALVE(060-060)	
5.	157-368	2	HOSE (120FX90L-149"-5000)	
6.	514-049	1	CONNECTOR (04S-06090)	
7.	157-378	1	HYD LINE (-06)	
8.	157-887	1	HYD LINE (-16)	
9.	157-886	1	HYD LINE (-16)	
10.	154-281	2	CONNECTOR (16S-160)	
11.	159-577	1	RELIEF MANIFOLD	
	150-1326	1	HYDRAULIC VALVE	
12.	105-857	8	BOLT (3/8-NC X 3", SOC, GD8)	
13.	159-686	1	HYD RELIEF VALVE, ADJ	
	191-426	-	SEAL REPAIR KIT	
14.	155-737	-	O-RING (214 D70)	
15.	150-1026	-	ROTATION MOTOR	
	150-1041	-	SEAL KIT	
16.	154-343	1	UNION (06S-060FX90)	

NOT SHOWN:

FOOTNOTES:

NOTE:

PUMP/ SELECTOR HYDRAULICS

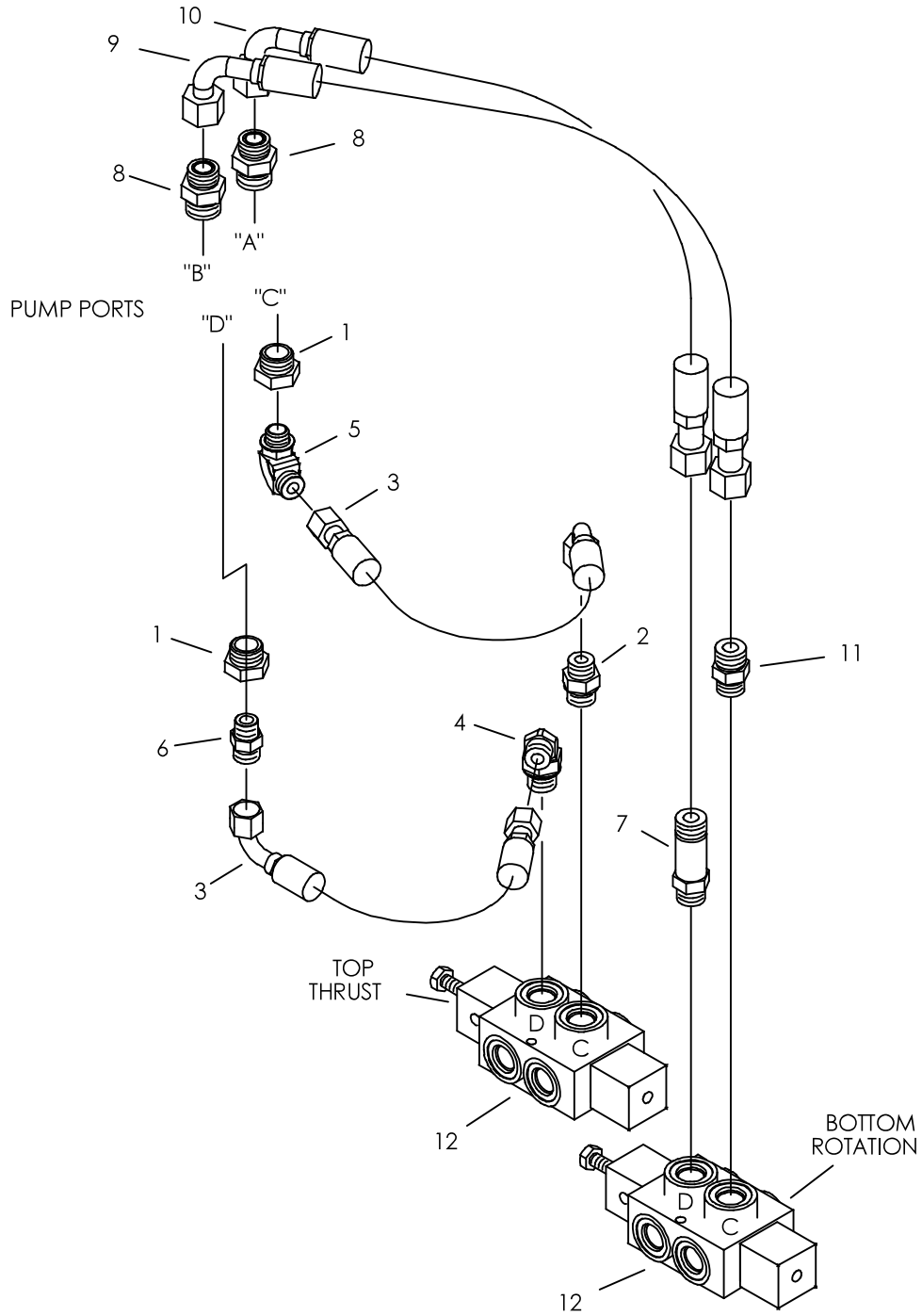

PUMP/ SELECTOR HYDRAULICS

REF NO.	PART NUMBER	QTY	DESCRIPTION	REMARKS
1.	155-199	2	REDUCER (16S-10SF)	
2.	154-308	1	CONNECTOR (100-12S)	
3.	153-295	2	HOSE (100FX90S-18"-3000)	
4.	154-300	1	CONNECTOR (100-12S90)	
5.	154-298	1	CONNECTOR (10S-10090)	
6.	154-301	1	CONNECTOR (10S-100)	
7.	514-048	1	CONNECTOR (12S-120, LG)	
8.	154-367	2	CONNECTOR (120-16S)	
9.	153-077	1	HOSE (120FX90S-32"-5000)	
10.	153-076	1	HOSE (120FX90S-28"-5000)	
11.	154-269	1	CONNECTOR (12S-120)	
12.	159-912	-	HYD CONTROL VALVE	
	191-396	-	SEAL KIT	
	500-1942	-	SEAL WASHER	

NOT SHOWN:

FOOTNOTES:

NOTE:

SELECTOR HYDRAULICS

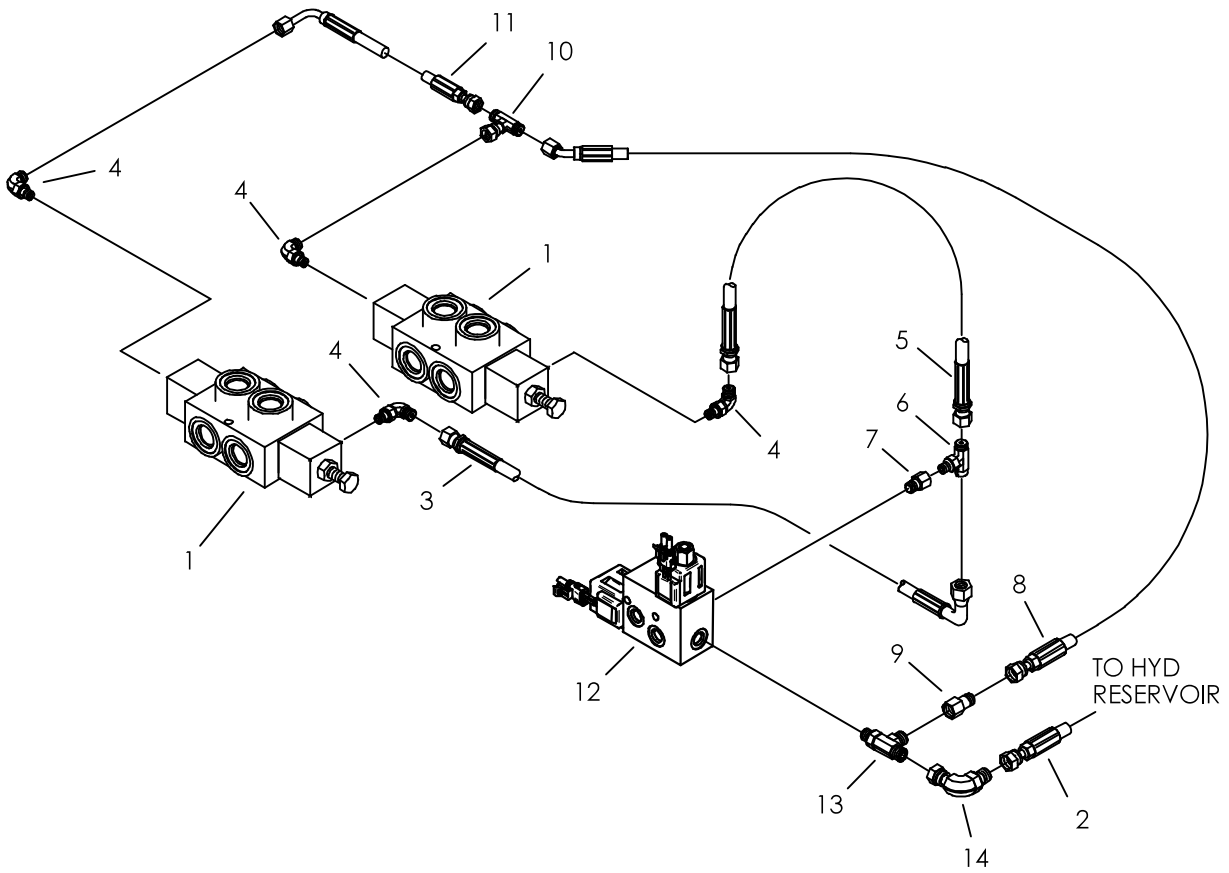

SELECTOR HYDRAULICS

REF NO.	PART NUMBER	QTY	DESCRIPTION	REMARKS
1.	159-912	-	HYD CONTROL VALVE	
	191-396	-	SEAL KIT	
	500-1942	-	SEAL WASHER	
2.	154-798	1	HOSE (060FX-62"-3000)	
3.	515-175	1	HOSE (040FX90-16"-3000)	
4.	154-252	4	CONNECTOR (04S-04090)	
5.	154-825	1	HOSE (040FX-12"-3000)	
6.	154-293	1	BRANCH TEE (04S-040-040)	
7.	155-254	1	REDUCER (06S-04SF)	
8.	515-331	1	HOSE (040FX45-22"-3000-AR)	
9.	154-373	1	REDUCER (040-060F)	
10.	154-379	1	UN BR TEE (040FX-040-040)	
11.	159-889	1	HOSE (040FX90L-8"-3000)	
12.	157-776	-	MANIFOLD	SEE NOT SHOWN FOR SERVICE PARTS.
13.	154-345	1	RUN TEE (06S-060-060)	
14.	154-228	1	UNION (060-060FX90)	

NOT SHOWN:

516-089	SOLENOID VALVE WITH NUT	USED ON 4 WAY VALVE
500-1541	SOLENOID VALVE WITH NUT	USED ON 3 WAY VALVE
213-216	SOLENOID COIL WITH DIODE	USED ON 4 WAY VALVE
213-196	SOLENOID COIL WITH DIODE	USED ON 3 WAY VALVE

FOOTNOTES:

NOTE:

THRUST HYDRAULICS

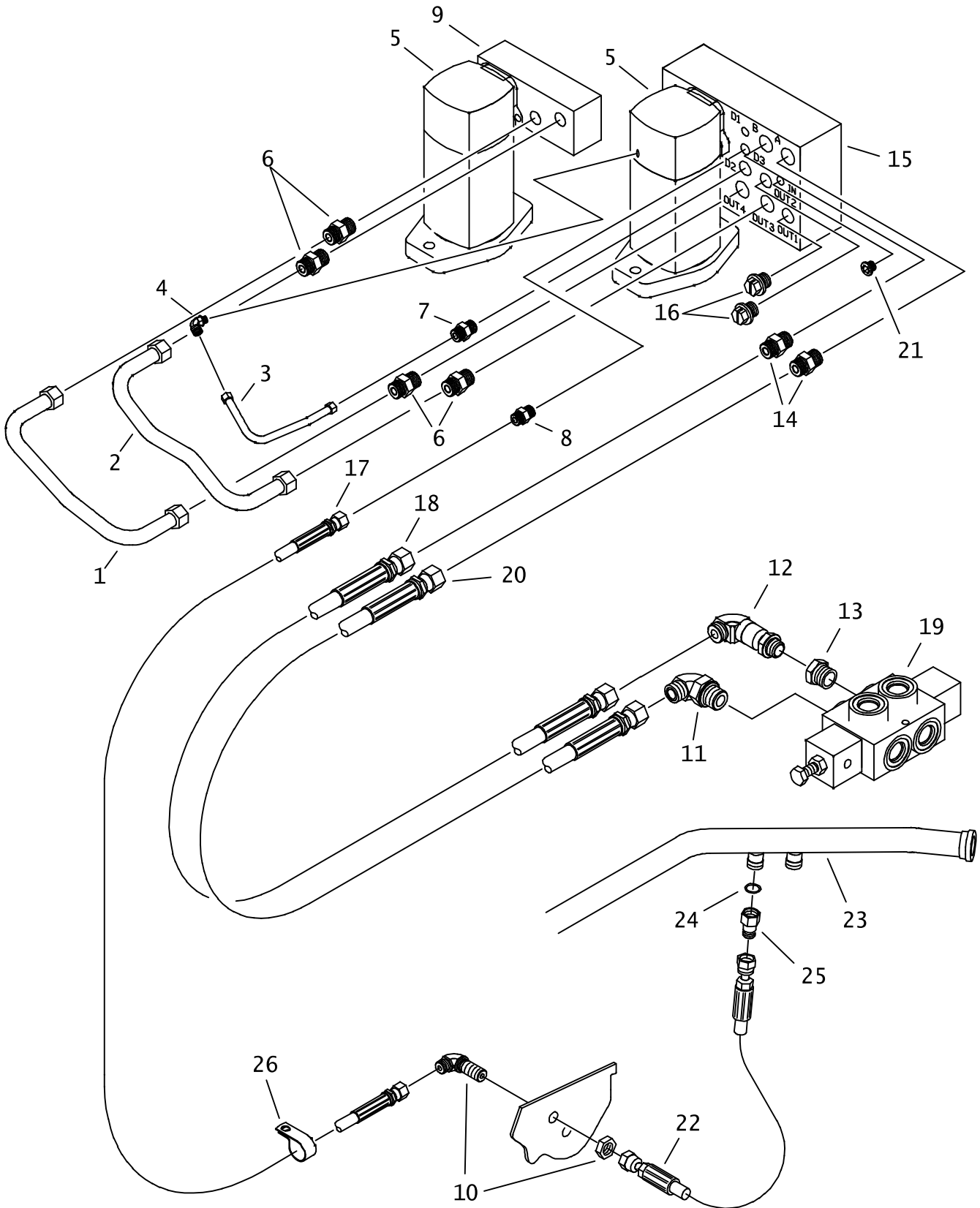

THRUST HYDRAULICS

REF NO.	PART NUMBER	QTY	DESCRIPTION	REMARKS
1.	157-377	1	HYD LINE (-12)	
2.	157-376	1	HYD LINE (-12)	
3.	157-379	1	HYD LINE (-06)	
4.	514-049	1	CONNECTOR (04S-06090)	
5.	157-317	-	MOTOR	
	500-1269		SEAL REPAIR KIT	
6.	154-247	4	CONNECTOR (10S-120)	
7.	154-222	1	CONNECTOR (060-08S)	
8.	154-221	1	CONNECTOR (06S-060)	
9.	157-339	-	MANIFOLD	
10.	154-229	1	BK CONNECTOR (060-06090BK)	
11.	154-300	1	CONNECTOR (100-12S90)	
12.	154-288	1	CONNECTOR (10S-10090, XL)	
13.	510-017	1	REDUCER (12S-10SF)	
14.	154-301	2	CONNECTOR (10S-100)	
15.	157-338	-	MANIFOLD	
16.	154-381	2	PLUG (08S)	
17.	515-350	1	HOSE (060FX-133"-3000)	
18.	159-784	1	HOSE (100FX-141"-3000)	
19.	159-912	-	HYD CONTROL VALVE	
	191-396	-	SEAL KIT	
	500-1942	-	SEAL WASHER	
20.	157-967	1	HOSE (100FX-139"-3000)	
21.	154-383	1	PLUG (04S)	
22.	515-089	1	HOSE (060FX-15"-3000)	
23.	157-254	-	HYD LINE	
24.	157-039	1	O-RING (014 D90)	
25.	154-262	1	REDUCER (060-080F)	
26.	110-333	1	BOLT-ON CLAMP (1")	

NOT SHOWN:

FOOTNOTES:

NOTE:

P.O.R. HYDRAULICS

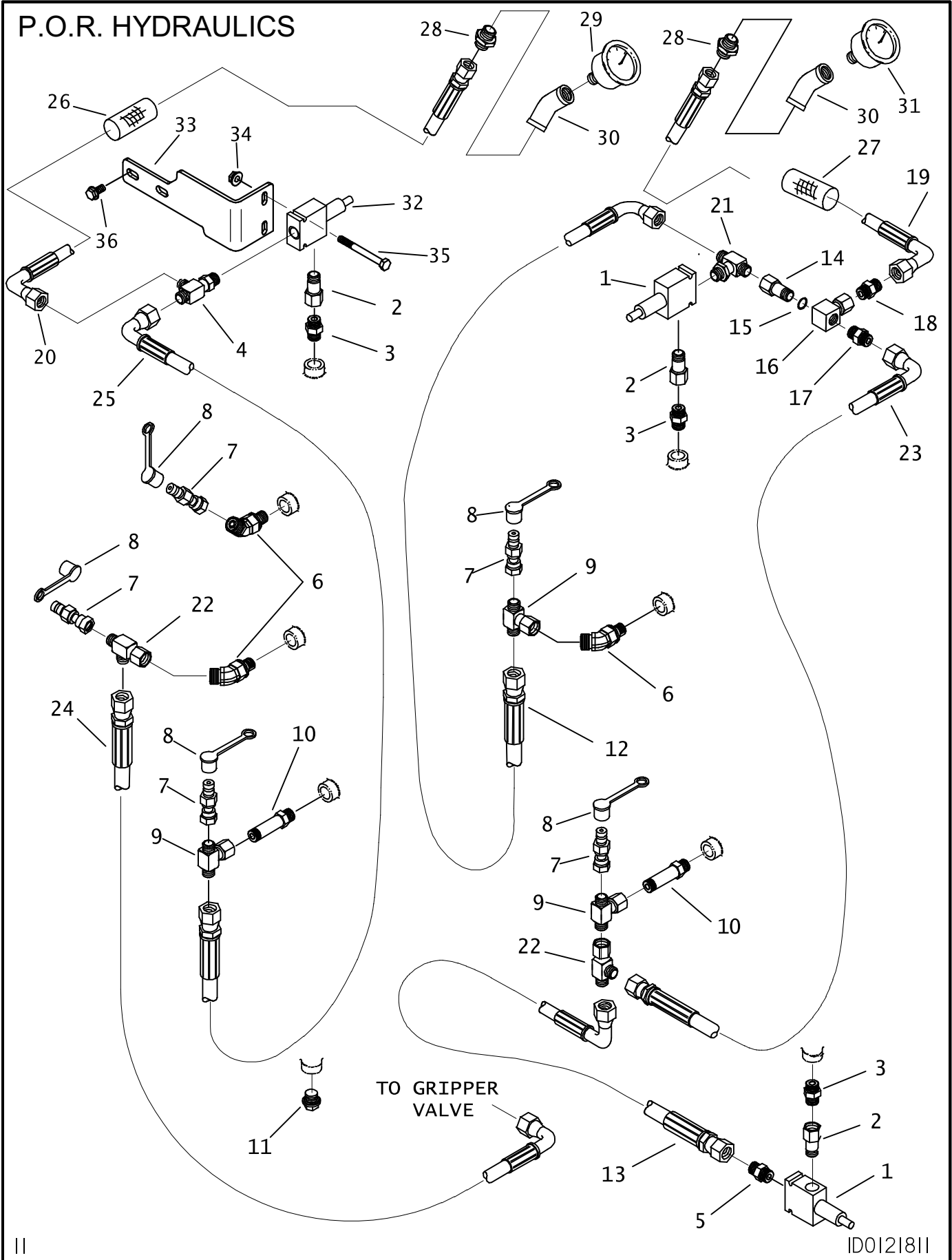

P.O.R. HYDRAULICS

REF NO.	PART NUMBER	QTY	DESCRIPTION	REMARKS
1.	158-681	2	HYD RELIEF VALVE	
	500-756	-	SEAL REPAIR KIT	
2.	155-163	3	REDUCER (08S-06SF)	
3.	155-153	3	CONNECTOR (06S-06S)	
4.	159-744	1	TEE (08S-060-040, .060 ORF)	
5.	159-743	1	CONNECTOR (08S-060, ORF)	
6.	154-224	3	CONNECTOR (06S-060 45)	
7.	159-157	5	QDC ADAPTER (02-060FX)	
8.	159-148	-	DUST CAP (1 / 8")	
9.	154-348	3	UN BR TEE (060FX-060-060)	
10.	156-174	2	CONNECTOR (06S-060)	
11.	155-130	-	PLUG (06S)	
12.	157-822	1	HOSE (060FX90-30"-3000)	
13.	153-320	1	HOSE (060FX90L-17"-3000)	
14.	514-409	1	UNION (06J-060FX)	
15.	155-705	1	O-RING (906 D90)	
16.	158-600	1	HYD SHUTTLE VALVE	
17.	154-221	1	CONNECTOR (06S-060)	
18.	154-220	1	CONNECTOR (040-06S)	
19.	515-072	1	HOSE (040FX45-16"-3000)	
20.	154-991	1	HOSE (040FX90S-36"-5000)	
21.	159-745	1	TEE (08S-060-060, .060 ORF)	
22.	154-344	2	UN RUN TEE (060FX-060-060)	
23.	153-768	1	HOSE (060FX90S-18"-3000)	
24.	157-823	1	HOSE (060FX90S-26"-3000)	
25.	153-877	1	HOSE (060FX90M-26"-5500)	
26.	117-718	1	ABRASION SLEEVE (1" x 36")	
27.	117-194	1	ABRASION SLEEVE (1.00" x 16")	
28.	154-339	2	CONNECTOR (04N-040)	
29.	258-045	-	GAUGE (4000 PSI)	
30.	514-418	2	ELBOW (04NF-04NF45)	
31.	217-294	-	PRESSURE GAUGE (3000 PSI)	
32.	159-832	1	HYD RELIEF VALVE	
	500-756	-	SEAL REPAIR KIT	
33.	300-4616	1	P.O.R. SUPPORT BRACKET	
34.	106-353	2	FLANGE NUT (M6-1.00)	
35.	106-595	2	SCREW (M6-1.00 X 60MM)	
36.	106-382	2	FLANGE LOCK SCREW (M10-1.5 X 20MM)	

NOT SHOWN:

FOOTNOTES:

NOTE:

||

ID0121811

GROUND DRIVE HYDRAULICS

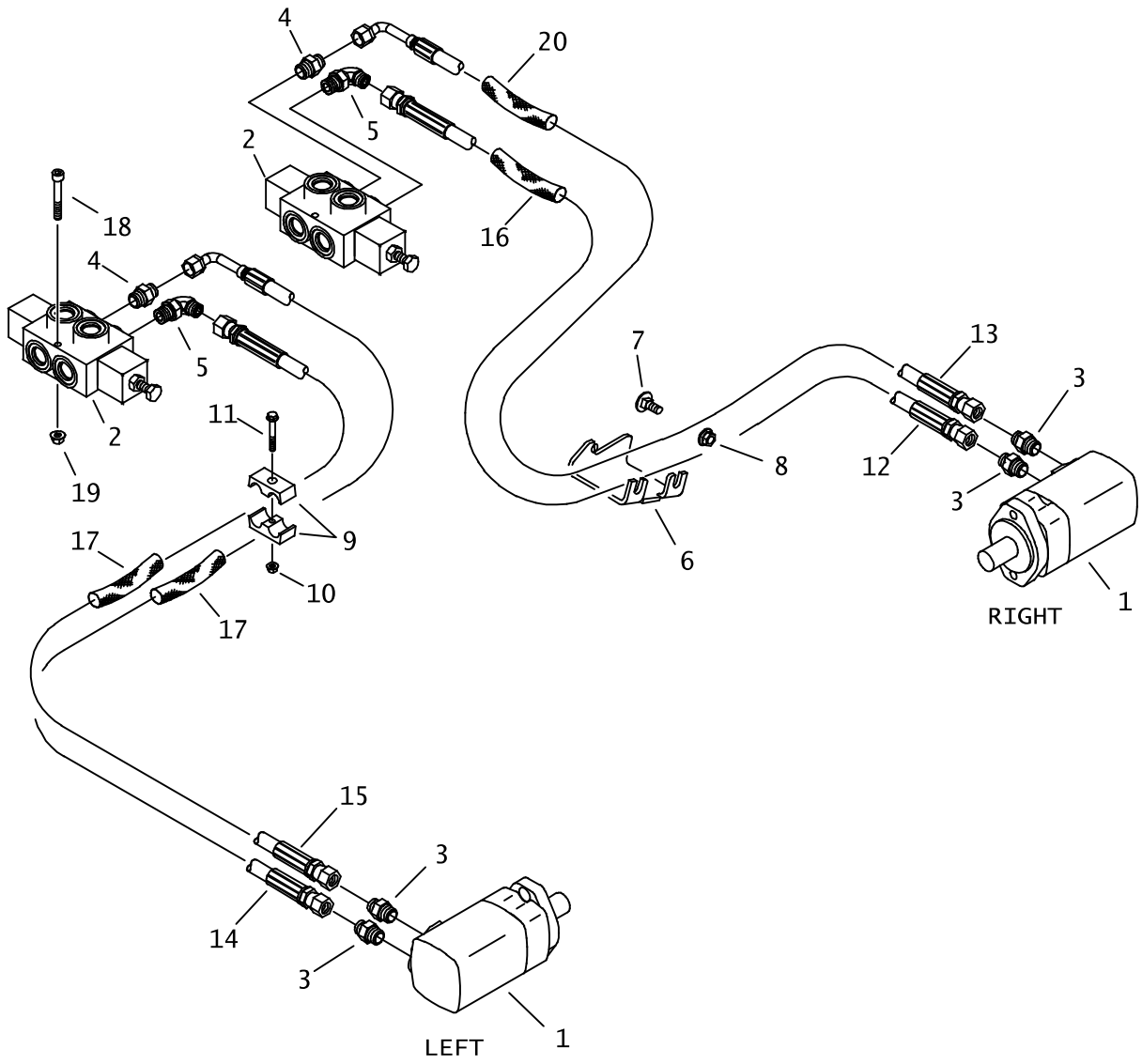

GROUND DRIVE HYDRAULICS

REF NO.	PART NUMBER	QTY	DESCRIPTION	REMARKS
1.	155-581	-	HYD MOTOR	
	500-658	-	SEAL REPAIR KIT	
2.	159-912	2	HYD CONTROL VALVE	
	191-396	-	SEAL KIT	
	500-1942	-	SEAL WASHER	
3.	154-279	4	CONNECTOR (080-10S)	
4.	154-234	2	CONNECTOR (080-12S)	
5.	154-236	2	CONNECTOR (080-12S90)	
6.	318-411	1	HOSE PROTECTOR	
7.	107-683	2	CARRIAGE BOLT(M12-1.75 X 30MM)	
8.	106-709	2	FLG LK NUT (M12-1.75)	
9.	110-277	1	CLAMP (.875", SOLD AS SET)	
10.	106-561	1	LOCKNUT (M8-1.25,PRV TRQ,10.9)	
11.	107-194	1	FLG SCREW (M8-1.25 X 50MM)	
12.	154-677	1	HOSE (080FX-62"-3000)	
13.	515-194	1	HOSE (080FX90L-64"-3000)	
14.	157-902	1	HOSE (080FX90M-83"-3000)	
15.	157-903	1	HOSE (080FX-80"-3000)	
16.	117-980	1	ABRASION SLEEVE (1.25" X 64")	
17.	117-981	2	ABRASION SLEEVE (1.25" X 82")	
18.	106-725	4	SCREW (M10-1.50 X 65MM, SOC)	
19.	105-894	4	LOCKNUT (M10-1.50,PRV TRQ,10.9)	SEE FOOTNOTE 1
20.	117-391	1	ABRASION SLEEVE (1.25" X 66")	

NOT SHOWN:

FOOTNOTES:

I. TIGHTEN ONLY ENOUGH TO HOLD PARTS IN PLACE, DO NOT OVERTIGHTEN.

NOTE:

ANCHOR HYDRAULICS

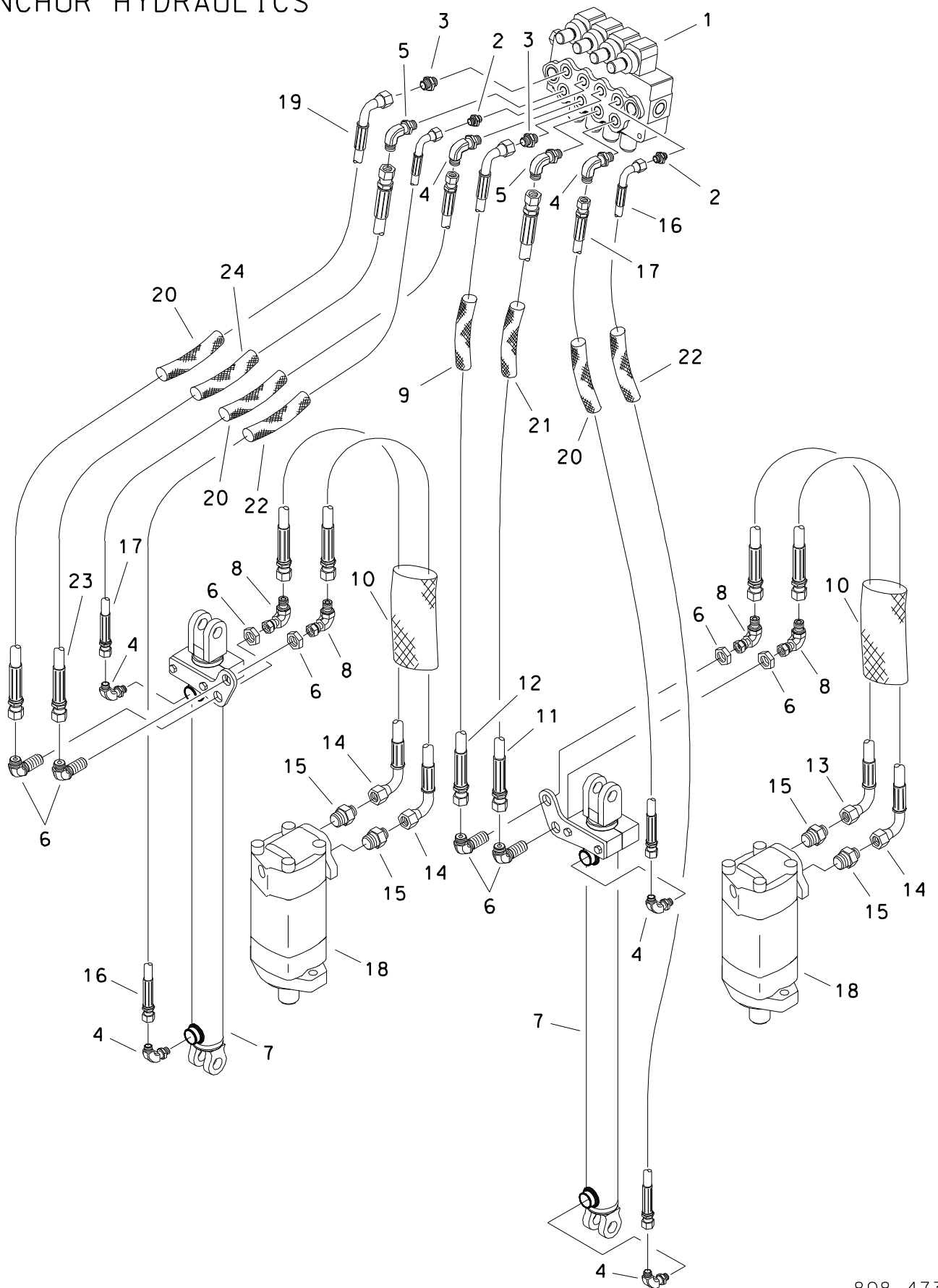

ANCHOR HYDRAULICS

REF NO.	PART NUMBER	QTY	DESCRIPTION	REMARKS
1.	157-241	-	ANCHOR VALVE	
2.	154-220	2	CONNECTOR (040-06S)	
3.	154-221	2	CONNECTOR (06S-060)	
4.	154-226	6	CONNECTOR (040-06S90)	
5.	154-342	2	CONNECTOR (06S-06090)	
6.	154-229	4	BK CONNECTOR (060-06090BK)	
7.	151-214	-	HYD CYL	
8.	154-228	4	UNION (060-060FX90)	
9.	117-409	1	ABRASION SLEEVE (1.00" X 28")	
10.	117-679	2	ABRASION SLEEVE (1.59" X 32")	
11.	515-711	1	HOSE (060FX-25"-3000)	
12.	149-335	1	HOSE (060FX90M-26"-3000)	
13.	157-822	1	HOSE (060FX90-30"-3000)	
14.	515-707	3	HOSE (060FX90-32"-3000)	
15.	154-369	4	CONNECTOR (060-10S)	
16.	157-910	2	HOSE (040FX90M-53"-3000)	
17.	515-755	2	HOSE (040FX-25"-3000)	
18.	158-700	-	HYD MOTOR	
	500-658	-	SEAL REPAIR KIT	
19.	157-951	1	HOSE (060FX90M-25"-3000)	
20.	117-280	3	ABRASION SLEEVE (1.00" X 25")	
21.	117-684	1	ABRASION SLEEVE (1.00" X 26")	
22.	117-994	2	ABRASION SLEEVE (1.00" X 53")	
23.	157-936	1	HOSE (060FX-22"-3000)	
24.	117-611	1	ABRASION SLEEVE (1.00" X 22")	

FOOTNOTES

LUBRICATOR HYDRAULICS

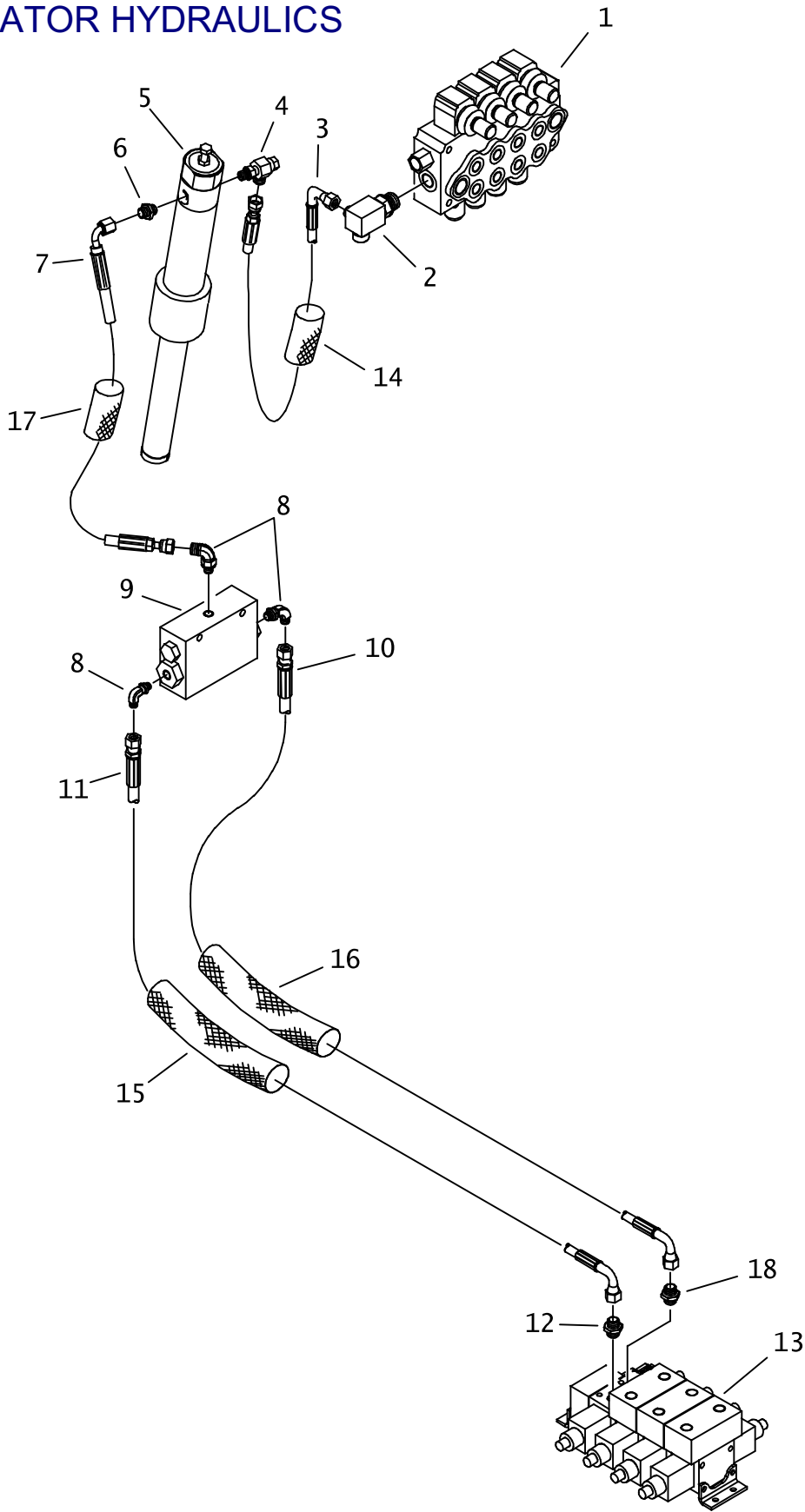

LUBRICATOR HYDRAULICS

REF NO.	PART NUMBER	QTY	DESCRIPTION	REMARKS
1.	157-241	-	ANCHOR VALVE	
2.	157-433	1	CONNECTOR (10S-060-040)	
3.	515-175	1	HOSE (040FX90-16"-3000)	
4.	159-797	1	CONNECTOR (04S-04090, ORF/CHK)	
5.	350-398	-	GREASE PUMP PARTS	
6.	154-278	1	CONNECTOR (04S-040)	
7.	515-284	1	HOSE (040FX90-24"-3000)	
8.	154-252	3	CONNECTOR (04S-04090)	
9.	310-591	-	VALVE	
10.	515-277	1	HOSE (040FX90S-128"-3000)	
11.	154-916	1	HOSE (040FX90S-120"-3000)	
12.	154-220	1	CONNECTOR (040-06S)	
13.	157-778	-	HYDRAULIC VALVE	
14.	117-194	1	ABRASION SLEEVE (1.00" X 16")	
15.	117-986	1	ABRASION SLEEVE (1.00" X 120")	
16.	117-399	1	ABRASION SLEEVE (1.00" X 130")	
17.	117-989	1	ABRASION SLEEVE (1.00" X 24")	
18.	514-074	1	CONNECTOR (06S-040, ORF)	

NOT SHOWN:

FOOTNOTES:

NOTE:

AUXILIARY HYDRAULICS

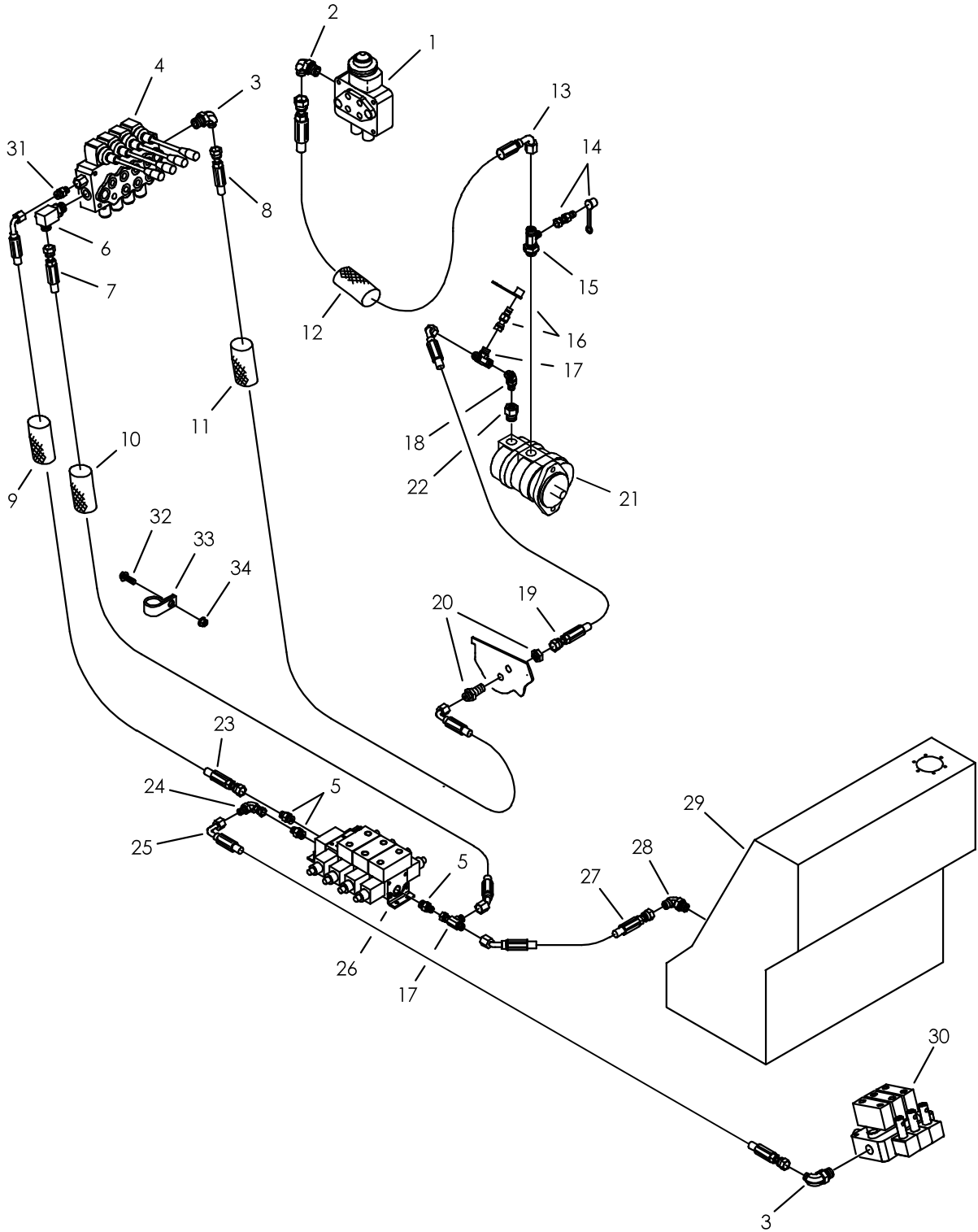

AUXILIARY HYDRAULICS

REF NO.	PART NUMBER	QTY	DESCRIPTION	REMARKS
1.	153-988	-	VALVE, HYDRAULIC DIRECTIONAL	
2.	154-322	1	CONNECTOR (080-10S90)	
3.	154-421	2	CONNECTOR (060-10S90)	
4.	157-241	-	ANCHOR VALVE	
5.	154-221	3	CONNECTOR (06S-060)	
6.	157-433	-	CONNECTOR (10S-060-040)	
7.	157-964	1	HOSE (060FX45-158"-3000)	
8.	157-965	1	HOSE (060FX90S-154"-3000)	
9.	117-997	1	ABRASION SLEEVE (1.00" X 147")	
10.	117-998	1	ABRASION SLEEVE (1.00" X 158")	
11.	117-999	1	ABRASION SLEEVE (1.00" X 154")	
12.	117-388	1	ABRASION SLEEVE (1.25" X 42")	
13.	515-025	1	HOSE (080FX90-40"-3000)	
14.	159-156	1	QDC ADAPTER (02-040F)	
15.	154-473	1	RUN TEE (10S-080-040)	
16.	159-157	1	QDC ADAPTER (02-060F)	
17.	154-344	2	UN RUN TEE (060FX-060-060)	
18.	154-224	1	CONNECTOR (06S-06045)	
19.	155-486	1	HOSE (060FX90-31"-3000)	
20.	514-163	1	BK CONNECTOR (060-060BK)	
21.	157-860	-	DOUBLE GEAR PUMP	
	500-967	-	SEAL KIT	
22.	155-171	1	REDUCER (10S-06SF)	
23.	157-963	1	HOSE (060FX90S-146"-3000)	
24.	154-228	1	UNION (060-060FX90)	
25.	157-962	1	HOSE (060FX90M-78"-3000)	
26.	157-778	-	HYDRAULIC VALVE	
	502-102	-	100 PSI DUAL PO CHECK	
27.	515-222	1	HOSE (060FX45-46"-3000)	
28.	154-227	1	CONNECTOR (060-08S90)	
29.	364-641	-	HYDRAULIC RESERVOIR	
30.	157-240	-	SET UP VALVE	
31.	154-222	1	CONNECTOR (060-08S)	
32.	105-271	1	SCREW (M10-1.5 X 40mm)	
33.	110-555	1	CLAMP (1-7/8")	
34.	106-387	1	FLG LOCKNUT (M10-1.50)	

NOT SHOWN:

FOOTNOTES:

NOTE:

DRILLING FLUID MOTOR HYDRAULICS

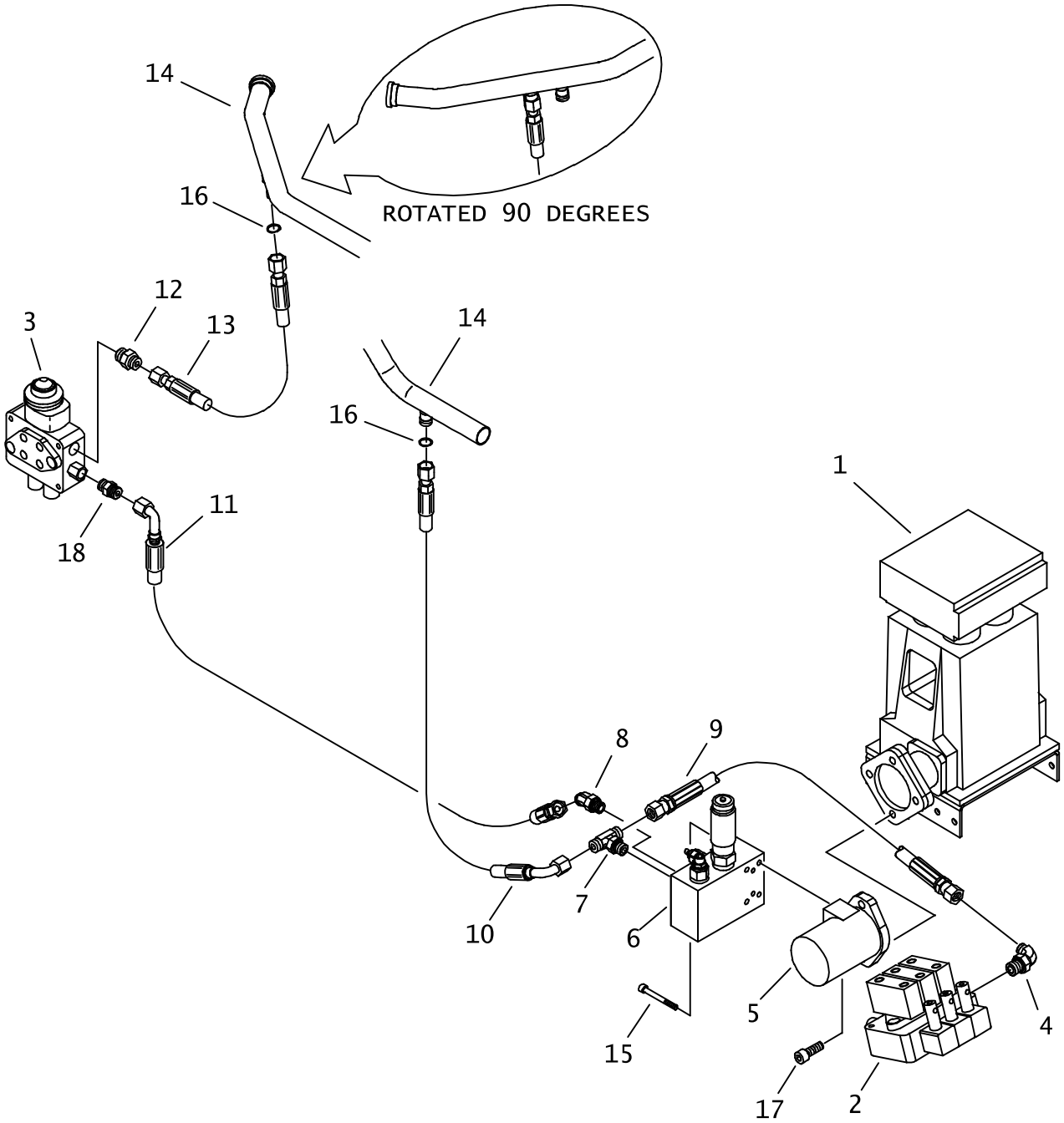

DRILLING FLUID MOTOR HYDRAULICS

REF NO.	PART NUMBER	QTY	DESCRIPTION	REMARKS
1.	157-267	-	DRILLING FLUID PUMP	
2.	157-240	-	SET UP VALVE	
3.	153-988	-	VALVE, HYDRAULIC DIRECTIONAL	
4.	154-322	1	CONNECTOR (080-10S90)	
5.	157-773	1	HYDRAULIC MOTOR	
	190-725	-	SEAL REPAIR KIT	
6.	157-774	1	MANIFOLD	
	500-1582	-	COMPENSATOR	
	500-1581	-	SEAL REPAIR KIT	
	500-1580	-	RELIEF VALVE	
	500-1579	-	SEAL REPAIR KIT	
	500-1583	-	SEAL REPAIR KIT	
7.	154-337	1	BRANCH TEE (08S-080-080)	
8.	154-284	1	CONNECTOR (08S-08045)	
9.	154-720	1	HOSE (080FX-20"-3000)	
10.	515-140	1	HOSE (080FX90-56"-3000)	
11.	515-741	1	HOSE (080FX90S-112"-3000)	
12.	154-279	1	CONNECTOR (080-10S)	
13.	154-759	1	HOSE (080FX-36"-3000)	
14.	157-254	-	HYD LINE	
15.	108-056	4	BOLT (5/16-NC X 2-1/2", SOC)	
16.	157-039	2	O-RING (014 D90)	
17.	106-204	2	BOLT (1/2-NC X 1-1/2", SOC)	TORQUE TO 100 FT-LBS, USE 242 LOCKTITE
18.	154-233	1	CONNECTOR (08S-080)	

NOT SHOWN:

FOOTNOTES:

NOTE:

ROTATING WRENCH HYDRAULICS

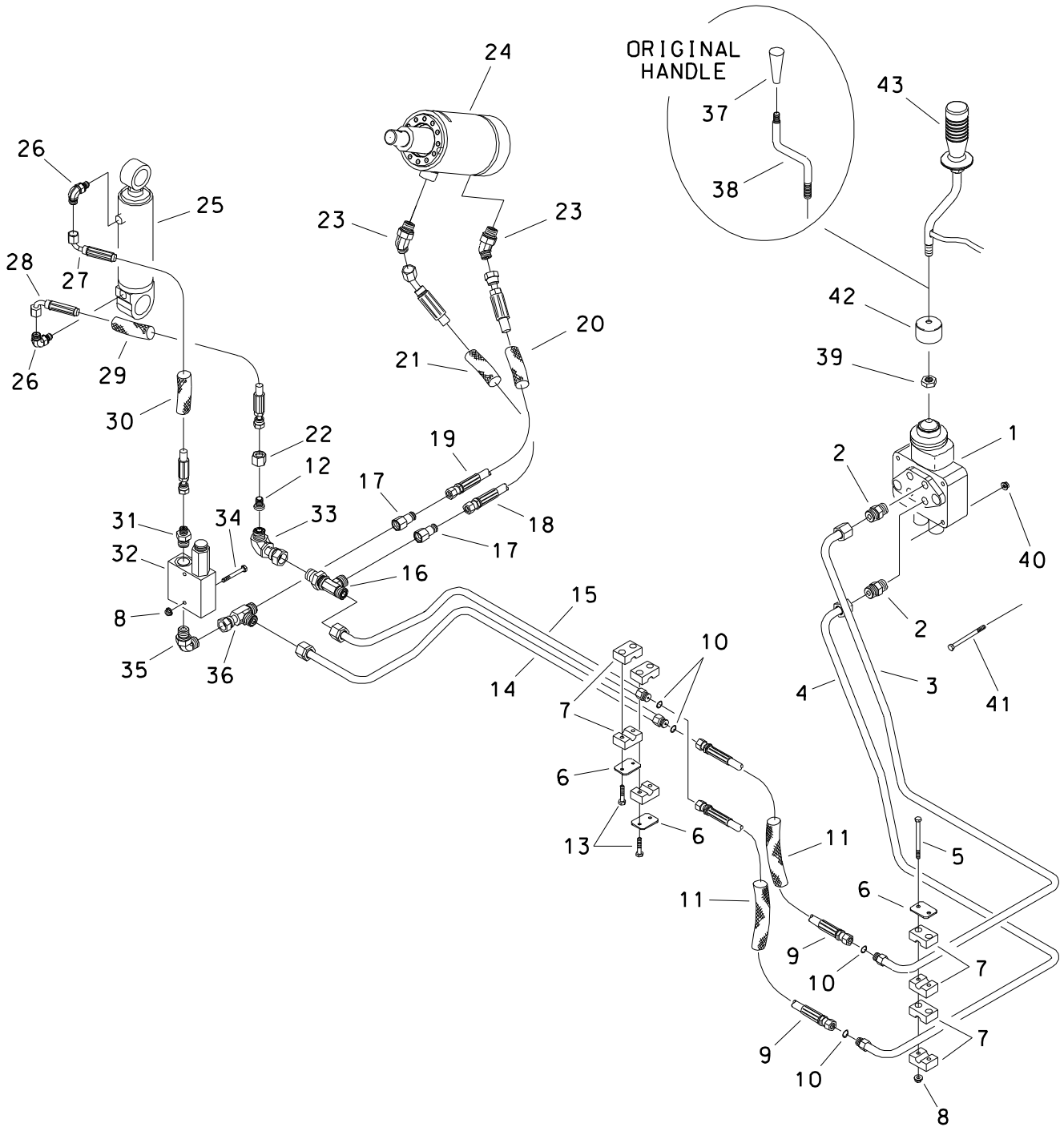

ROTATING WRENCH HYDRAULICS

REF NO.	PART NUMBER	QTY	DESCRIPTION	REMARKS
1.	153-988	1	VALVE, HYDRAULIC DIRECTIONAL	
2.	154-233	2	CONNECTOR (08S-080)	
3.	157-462	1	HYD LINE (-08)	
4.	157-463	1	HYD LINE (-08)	
5.	105-843	2	SCREW (M6-1.00 X 80MM)	
6.	110-958	3	BACKUP PLATE	
7.	110-866	4	CLAMP SET (1/2")	
8.	106-385	4	FLG LOCKNUT (M6-1.00)	
9.	154-807	2	HOSE (060FX-24"-3000)	
10.	157-038	4	O-RING (012 D90)	
11.	117-280	2	ABRASION SLEEVE (1.00" X 25")	
12.	154-248	1	REDUCER STEM (040)	
13.	105-818	4	BOLT (1/4-NC X 1-1/2")	
14.	157-496	1	HYD LINE (-08)	
15.	157-497	1	HYD LINE (-08)	
16.	154-295	1	BK RUN TEE (080-080-080BK)	
17.	154-262	2	REDUCER (060-080F)	
18.	157-937	1	HOSE (060FX45-29"-3000)	
19.	159-846	1	HOSE (060FX-26"-3000)	
20.	117-684	1	ABRASION SLEEVE (1.00" X 26")	
21.	117-409	1	ABRASION SLEEVE (1.00" X 28")	
22.	154-272	1	REDUCER NUT (080F)	
23.	154-225	2	CONNECTOR (060-08S45)	
24.	151-213	-	CYL (3.5 X 1.75 X 2.0)	
25.	151-038	-	CYL (2.0 X 1.0 X 4.0)	
26.	154-252	2	CONNECTOR (04S-04090)	
27.	515-598	1	(040FX90-12"-3000)	
28.	515-599	1	(040FX90-13"-3000)	
29.	117-671	1	ABRASION SLEEVE (1.00" X 12")	
30.	117-278	1	ABRASION SLEEVE (1.00" X 14")	
31.	154-261	1	CONNECTOR (040-08S)	
32.	157-249	1	SEQUENCE VALVE	
33.	154-256	1	UNION (080-080FX90)	
34.	107-025	2	SCREW (M6-1.00 X 50MM)	
35.	154-235	1	CONNECTOR (08S-08090)	
36.	154-266	1	UNION RUN TEE (080FX-080-080)	
37.	110-439	-	KNOB (3/8-NC, BLACK)	
38.	166-495	-	SHAFT	
39.	107-669	1	JAM NUT (M12-1.75)	
40.	106-386	3	FLG LOCKNUT (M8-1.25)	
41.	106-570	3	SCREW (M8-1.25 X 60MM)	
42.	111-077	1	VINYL CAP (1.625")	
43.	118-370	1	HANDLE	

FOOTNOTES

STATIONARY WRENCH HYDRAULICS

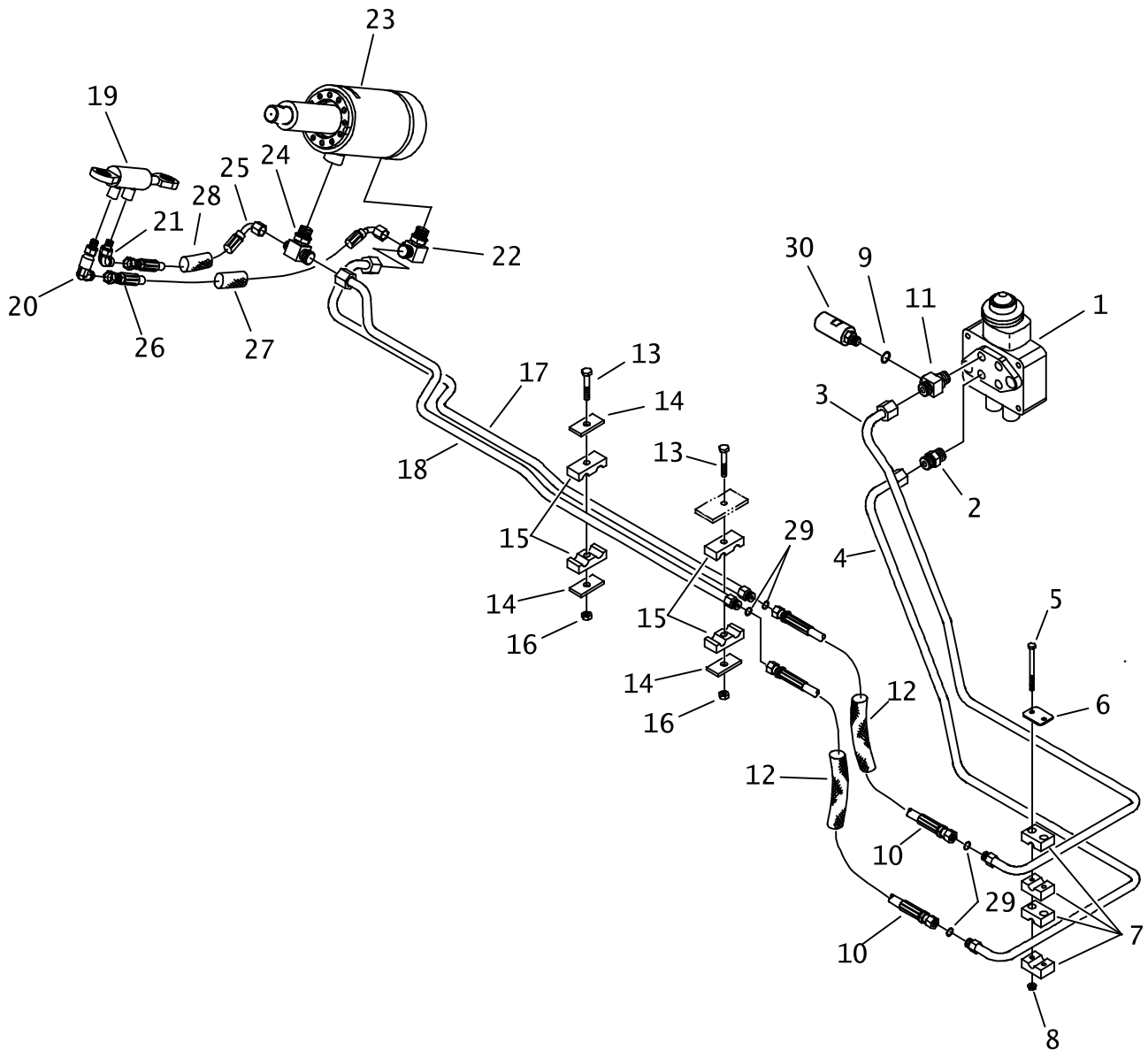

STATIONARY WRENCH HYDRAULICS

REF NO.	PART NUMBER	QTY	DESCRIPTION	REMARKS
1.	153-988	-	VALVE, HYDRAULIC DIRECTIONAL	
2.	154-233	1	CONNECTOR (08S-080)	
3.	157-464	1	HYD LINE (-08)	
4.	157-465	1	HYD LINE (-08)	
5.	105-843	2	SCREW (M6-1.00 X 80MM)	
6.	110-958	1	BACKUP PLATE	
7.	110-866	2	CLAMP SET (1/2")	
8.	106-385	2	FLG LOCKNUT (M6-1.00)	
9.	155-705	1	O-RING (906 D90)	
10.	154-807	2	HOSE (060FX-24"-3000)	
11.	157-932	1	RUN TEE (08S-080-06SF)	
12.	117-280	2	ABRASION SLEEVE (1.00" X 25")	
13.	106-329	2	SCREW (M8-1.25 X 50MM)	
14.	305-256	3	BACKUP SPACER	
15.	110-270	4	BOLT-ON CLAMP (9/16", HALF)	
16.	107-096	2	LOCKNUT (M8-1.25, NLK)	
17.	157-494	1	HYD LINE (-08)	
18.	157-495	1	HYD LINE (-08)	
19.	151-220	-	CYLINDER (1.0 X .50 X .90)	
20.	154-474	1	CONNECTOR (04S-04090, XL)	
21.	154-252	1	CONNECTOR (04S-04090)	
22.	514-160	1	BRANCH TEE (08S-080-040)	
23.	151-213	-	CYL (3.5 X 1.75 X 2.0)	
24.	157-769	1	BRANCH TEE (08S-080-040)	
25.	153-364	1	HOSE (040FX90S-13"-3000)	
26.	154-857	1	HOSE (040FX90-19"-3000)	
27.	117-328	1	ABRASION SLEEVE (1.00" X 18")	
28.	117-671	1	ABRASION SLEEVE (1" X 12")	
29.	157-038	4	O-RING (012 D90)	
30.	215-1204	1	PRESSURE SWITCH (1850PSI)	

NOT SHOWN:

FOOTNOTES:

NOTE:

PIPE GRIP HYDRAULICS

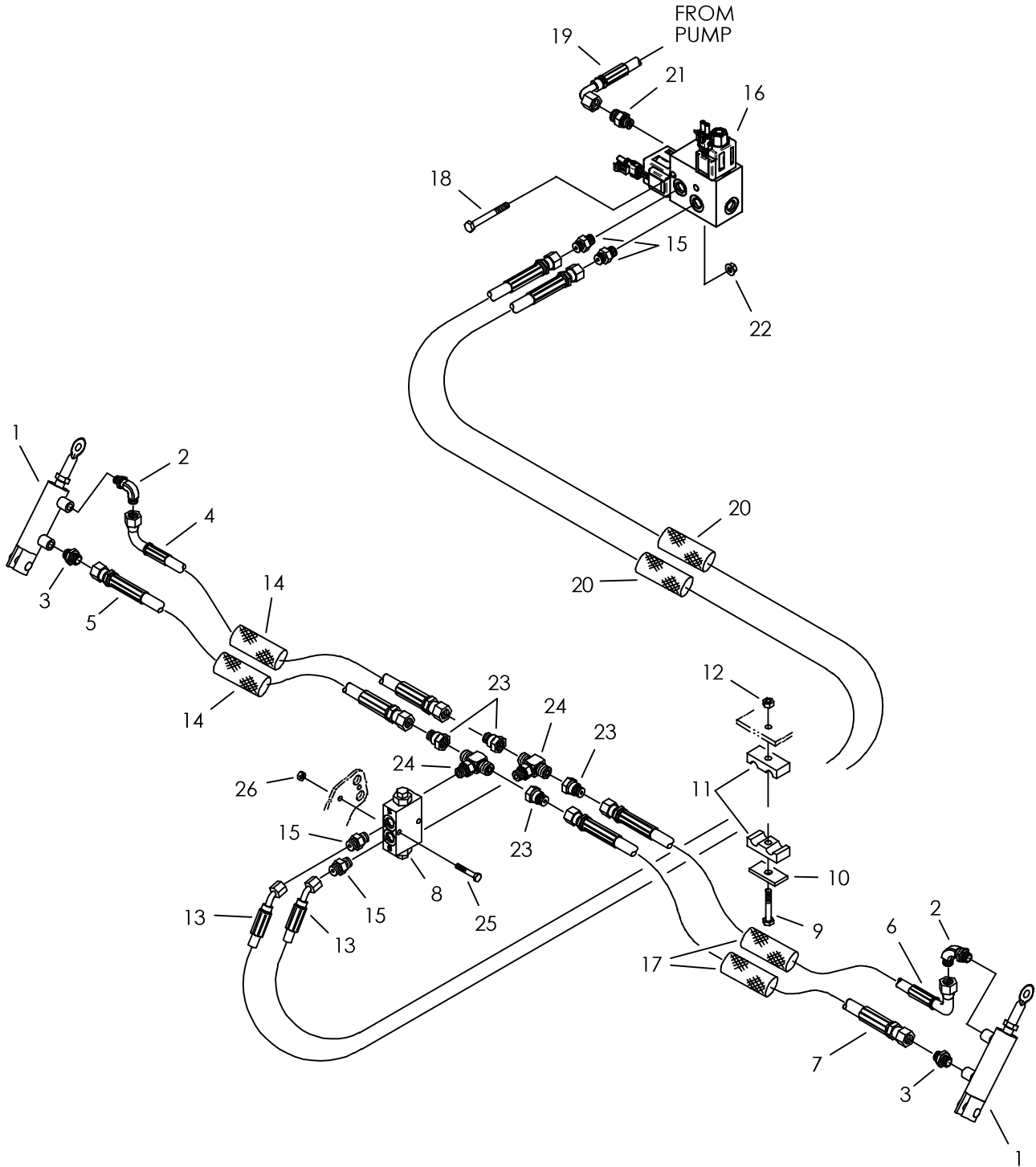

PIPE GRIP HYDRAULICS

REF NO.	PART NUMBER	QTY	DESCRIPTION	REMARKS
1.	151-150	-	CYL (1.5" X .50" X 2")	
2.	154-252	2	CONNECTOR (04S-04090)	
3.	154-278	2	CONNECTOR (04S-040)	
4.	153-307	1	(040FX90S-38"-3000)	
5.	154-695	1	HOSE (040FX-38"-3000)	
6.	153-365	1	HOSE (040FX90S-34"-3000)	
7.	515-229	1	HOSE (040FX-34"-3000)	
8.	149-136	1	HYD LOCKOUT VALVE	
9.	106-329	1	SCREW (M8-1.25 X 50MM)	
10.	305-256	1	BACKUP SPACER	
11.	110-270	2	BOLT-ON CLAMP (9/16", HALF)	
12.	107-096	1	LOCKNUT (M8-1.25, NLK)	
13.	515-425	2	HOSE (040FX45-42"-3000)	
14.	117-717	2	ABRASION SLEEVE (1.00" X 40")	
15.	154-220	4	CONNECTOR (040-06S)	
16.	157-776	1	MANIFOLD	SEE NOT SHOWN FOR SERVICE PARTS.
17.	117-718	2	ABRASION SLEEVE (1" X 36")	
18.	106-330	2	SCREW (M8-1.25 X 70MM)	
19.	157-823	-	HOSE (060FX90S-26"-3000)	USE ON JT1220
	515-586	-	HOSE (060FX90S-21"-3000)	USE ON JT2020
20.	117-387	2	ABRASION SLEEVE (1.00" X 42")	
21.	154-221	1	CONNECTOR (06S-060)	
22.	106-386	2	FLG LOCKNUT (M8-1.25)	
23.	154-373	4	REDUCER (040-060F)	
24.	154-346	2	BRANCH TEE (06S-060-060)	
25.	105-818	2	BOLT (1/4-NC X 1-1/2")	
26.	105-085	2	LOCKNUT (1/4-NC)	

NOT SHOWN:

516-089	SOLENOID VALVE WITH NUT	USED ON 4 WAY VALVE
500-154I	SOLENOID VALVE WITH NUT	USED ON 3 WAY VALVE
213-216	SOLENOID COIL WITH DIODE	USED ON 4 WAY VALVE
213-196	SOLENOID COIL WITH DIODE	USED ON 3 WAY VALVE

FOOTNOTES:

NOTE:

SHUTTLE HYDRAULICS

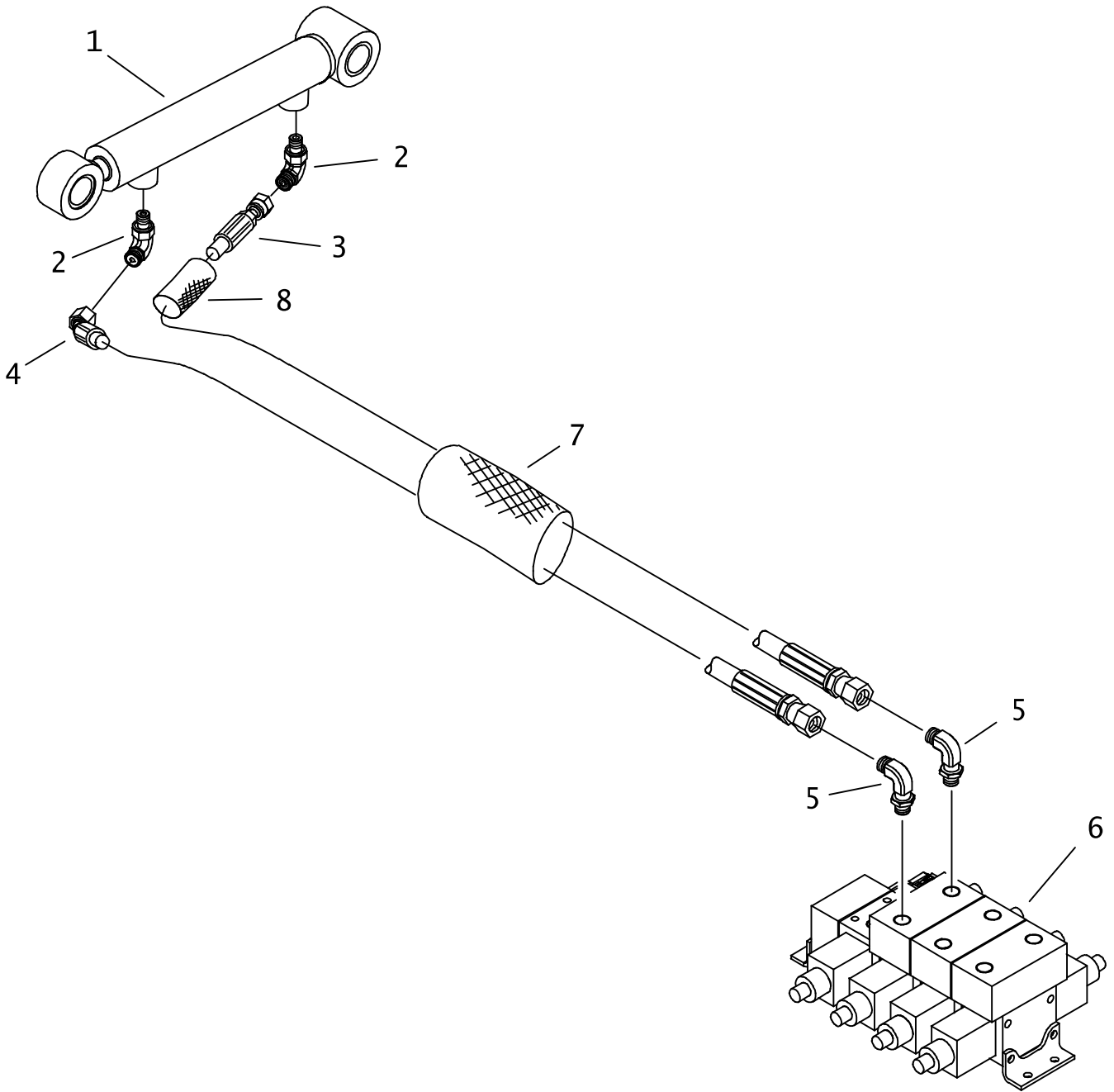

SHUTTLE HYDRAULICS

REF NO.	PART NUMBER	QTY	DESCRIPTION	REMARKS
1.	151-230	-	CYL (1.25" X .75" X 6")	
2.	154-252	2	CONNECTOR (04S-04090)	
3.	515-054	1	HOSE (040FX-74"-3000)	
4.	515-120	1	HOSE (040FX45-67"-3000)	
5.	154-226	2	CONNECTOR (040-06S90)	
6.	157-778	-	HYDRAULIC VALVE	
7.	117-391	1	ABRASION SLEEVE (1.25" X 66")	
8.	117-670	1	ABRASION SLEEVE (1" X 10")	

NOT SHOWN:

FOOTNOTES:

NOTE:

PIPE LIFT HYDRAULICS

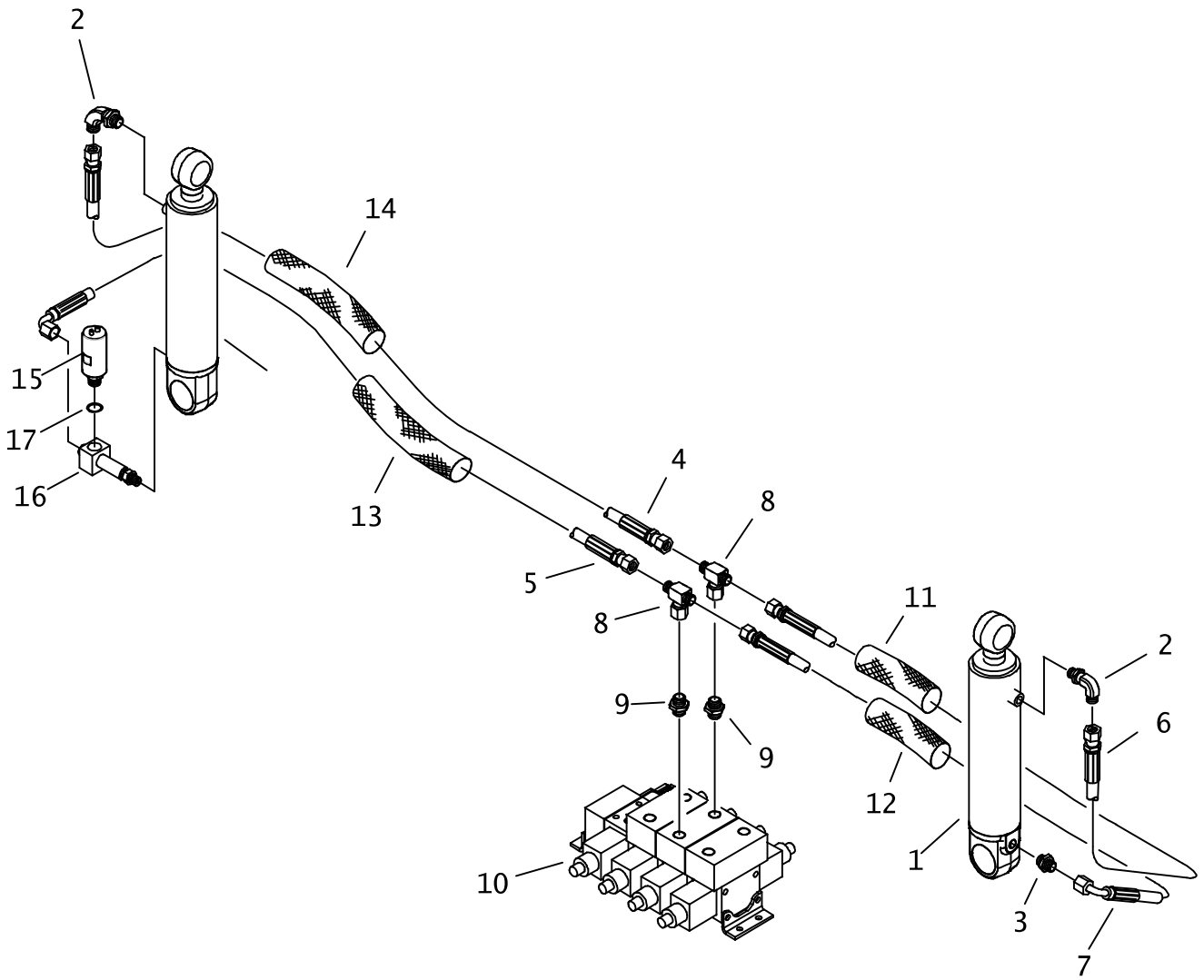

PIPE LIFT HYDRAULICS

REF NO.	PART NUMBER	QTY	DESCRIPTION	REMARKS
1.	151-044	-	CYL (2.0 X 1.0 X 6.0)	
2.	154-252	2	CONNECTOR (04S-04090)	
3.	154-278	1	CONNECTOR (04S-040)	
4.	157-918	1	HOSE (040FX-88"-3000)	
5.	157-911	1	HOSE (040FX90S-85"-3000)	
6.	154-695	1	HOSE (040FX-38"-3000)	
7.	515-011	1	HOSE (040FX90-32"-3000)	
8.	154-379	2	UN BR TEE (040FX-040-040)	
9.	154-220	2	CONNECTOR (040-06S)	
10.	157-778	-	HYDRAULIC VALVE	
11.	117-717	1	ABRASION SLEEVE (1.00" X 40")	
12.	117-412	1	ABRASION SLEEVE (1.00" X 34")	
13.	117-398	1	ABRASION SLEEVE (1.00" X 86")	
14.	117-209	1	ABRASION SLEEVE (1.00" X 90")	
15.	215-1204	1	PRESSURE SWITCH (1850PSI)	
16.	157-933	1	RUN TEE (04S-040-06SF)	
17.	155-705	1	O-RING (906 D90)	

NOT SHOWN:

FOOTNOTES:

NOTE:

PIPE BOX SHIFT HYDRAULICS

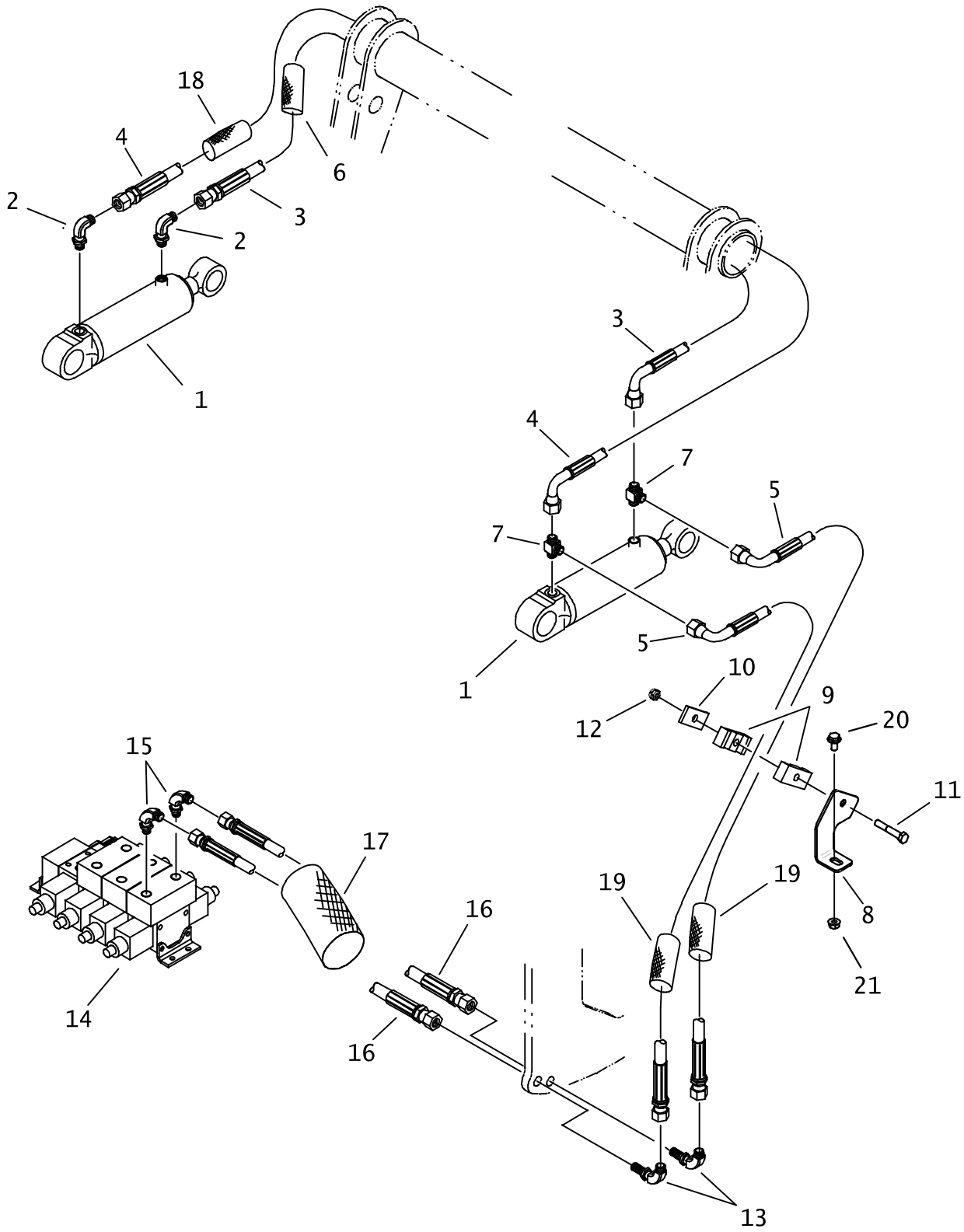

PIPE BOX SHIFT HYDRAULICS

REF NO.	PART NUMBER	QTY	DESCRIPTION	REMARKS
1.	151-038	-	CYL (2.0 X 1.0 X 4.0)	
2.	154-252	2	CONNECTOR (04S-04090)	
3.	515-471	1	HOSE (040FX90-147"-3000)	
4.	153-283	1	HOSE (040FX90S-157"-3000)	
5.	515-447	2	HOSE (040FX90S-48"-3000)	
6.	117-997	1	ABRASION SLEEVE (1.00" X 147")	
7.	154-316	2	RUN TEE (04S-040-040)	
8.	327-670	1	CLAMP BRACKET	
	319-520	-	CLAMP BRACKET	NOT SHOWN. BRACKET ON CYLINDER SIDE OF HOSES
9.	110-270	2	BOLT-ON CLAMP (9/16", HALF)	
10.	305-256	1	BACKUP SPACER	
11.	106-329	1	SCREW (M8-1.25 X 50MM)	
12.	107-096	1	LOCKNUT (M8-1.25, NLK)	
13.	154-355	2	BK CONNECTOR (040-04090BK)	
14.	157-778	-	HYDRAULIC VALVE	
15.	154-226	2	CONNECTOR (040-06S90)	
16.	515-013	2	HOSE (040FX-42"-3000)	
17.	117-388	1	ABRASION SLEEVE (1.25" X 42")	
18.	117-998	1	ABRASION SLEEVE (1.00" X 158")	
19.	117-416	2	ABRASION SLEEVE (1.00" X 50")	
20.	106-380	1	FLG LK SCREW (M8-1.25 X 16MM)	
21.	106-386	1	FLG LOCKNUT (M8-1.25)	

FOOTNOTES

NOTE:

C

808-487

FRAME TILT HYDRAULICS

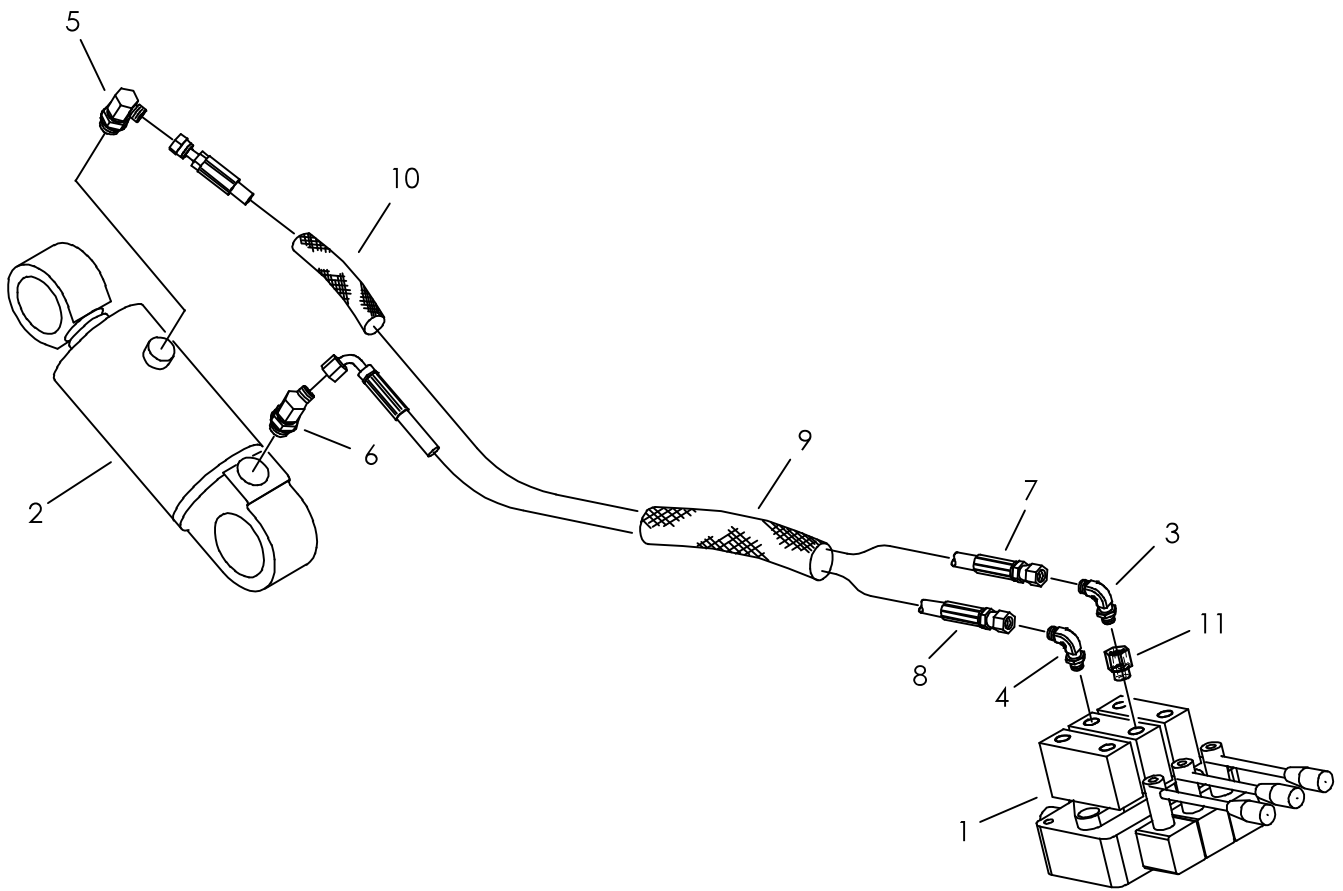

FRAME TILT HYDRAULICS

REF NO.	PART NUMBER	QTY	DESCRIPTION	REMARKS
1.	157-240	-	SET UP VALVE	
2.	151-089	-	CYL (3.5 X 1.75 X 3.0)	
3.	154-364	1	CONNECTOR (040-06S90,ORF)	
4.	154-226	1	CONNECTOR (040-06S90)	
5.	154-276	1	CONNECTOR (040-08S90)	
6.	154-223	1	CONNECTOR (040-08S45)	
7.	154-725	1	HOSE (040FX-90"-3000)	
8.	515-075	1	HOSE (040FX90S-82"-3000)	
9.	117-556	1	ABRASION SLEEVE (1.25" X 80")	
10.	117-982	1	ABRASION SLEEVE (1" X 6")	
11.	159-931	1	CONNECTOR (06S-06SF)	

NOT SHOWN:

FOOTNOTES:

NOTE:

STABILIZER HYDRAULICS

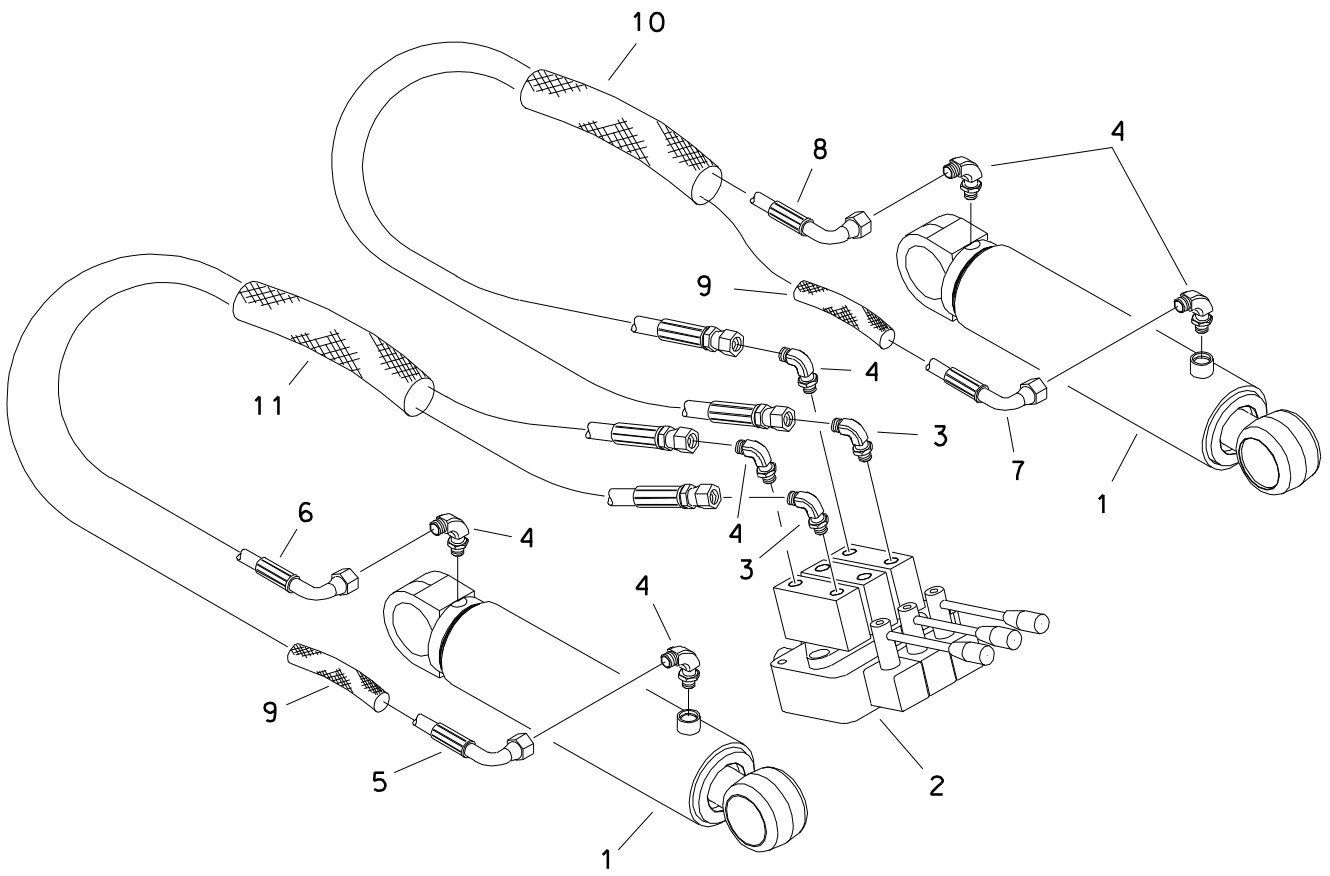

STABILIZER HYDRAULICS

REF NO.	PART NUMBER	QTY	DESCRIPTION	REMARKS
1.	151-029	-	CYL (3.0 X 1.50 X 10.0)	
2.	157-240	-	SET UP VALVE	
3.	154-364	2	CONNECTOR (040-06S90,DRF)	
4.	154-226	6	CONNECTOR (040-06S90)	
5.	515-190	1	HOSE (040FX90S-88"-3000)	
6.	515-074	1	HOSE (040FX90S-77"-3000)	
7.	515-447	1	HOSE (040FX90S-48"-3000)	
8.	154-728	1	HOSE (040FX90S-36"-3000)	
9.	117-608	2	ABRASION SLEEVE (1.00" X 15")	
10.	117-323	1	ABRASION SLEEVE (1.25" X 37")	
11.	117-244	1	ABRASION SLEEVE (1.25" X 78")	

FOOTNOTES

HYDRAULIC VALVE PARTS

157-778

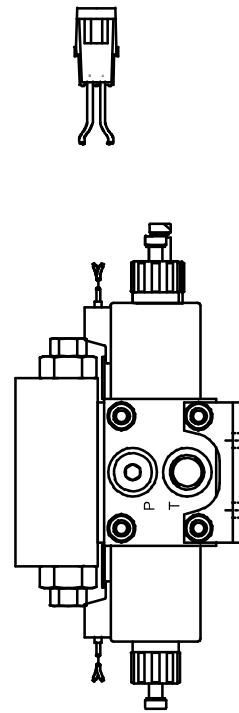
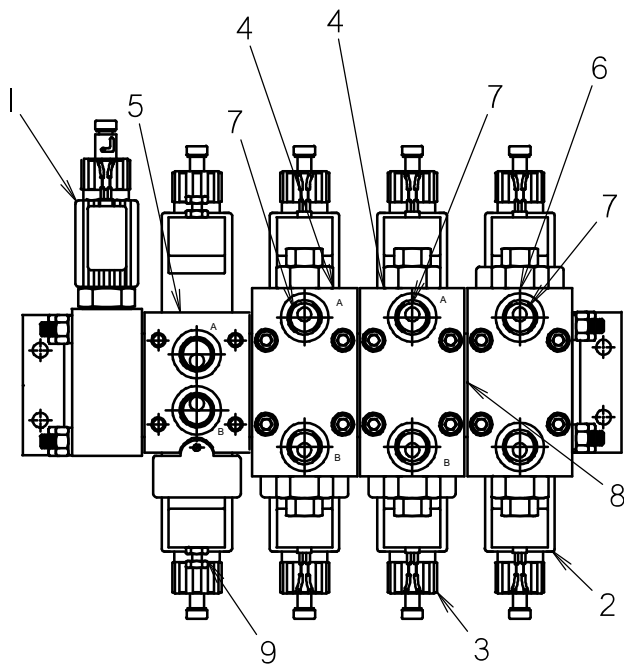

HYDRAULIC VALVE PARTS

157-778

REF NO.	PART NUMBER	QTY	DESCRIPTION	REMARKS
1.	500-1034	1	UNLOADING INLET SUB ASSEMBLY	500-2112 - Cartridge only
2.	217-948	8	COIL, 12VDC	
3.	149-616	8	CAP NUT	
4.	500-1036	2	BV06 CONTROL VALVE SECTION	
5.	500-1037	1	BV06 CONTROL VALVE SECTION	
6.	500-1038	1	BV06 CONTROL VALVE SECTION	
7.	502-102	3	100 PSI DUAL PO CHECK	
8.	190-997	3	STACKING KIT	
9.	500-2004	4	BV06 CORE TUBE	

NOT SHOWN:

FOOTNOTES:

NOTE:

HYDRAULIC CYLINDERS (2.0" X 1.0")

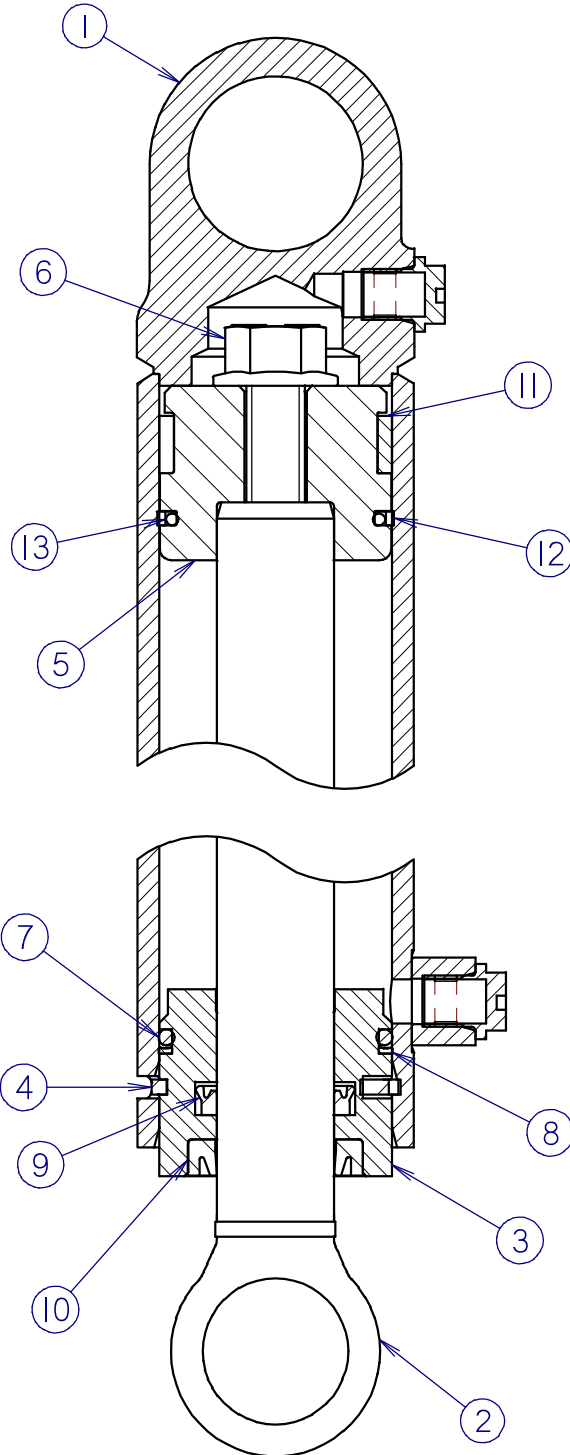

HYDRAULIC CYLINDERS (2.0" X 1.0")

REF NO.	PART NUMBER	QTY	DESCRIPTION	REMARKS
	151-094	-	CYL (2.0 X 1.0 X 2.0)	SEE FOOTNOTES 1 & 2
1	152-029	1	CYLINDER BARREL (2.0 X 2.0)	
2	153-007	1	CYLINDER ROD (1.00 X 2.0)	
	149-667	-	CYL (2.0 X 1.0 X 2.5)	SEE FOOTNOTES 1 & 2
1	149-761	1	CYLINDER BARREL (2.0 X 2.5)	
2	149-728	1	CYLINDER ROD (1.00 X 2.5)	
	151-027	-	CYL (2.0 X 1.0 X 3.0)	SEE FOOTNOTES 1 & 2
1	150-282	1	CYLINDER BARREL (2.0 X 3.0)	
2	150-414	1	CYLINDER ROD (1.00 X 3.0)	
	151-038	-	CYL (2.0 X 1.0 X 4.0)	SEE FOOTNOTES 1 & 2
1	150-290	1	CYLINDER BARREL (2.0 X 4.0)	
2	150-421	1	CYLINDER ROD (1.00 X 4.0)	
	151-039	-	CYL (2.0 X 1.0 X 5.0)	SEE FOOTNOTES 1 & 2
1	150-291	1	CYLINDER BARREL (2.0 X 5.0)	
2	150-422	1	CYLINDER ROD (1.00 X 5.0)	
	151-044	-	CYL (2.0 X 1.0 X 6.0)	SEE FOOTNOTES 1 & 2
1	150-294	1	CYLINDER BARREL (2.0 X 6.0)	
2	150-424	1	CYLINDER ROD (1.00 X 6.0)	
	151-031	-	CYL (2.0 X 1.0 X 8.0)	SEE FOOTNOTES 1 & 2
1	150-285	1	CYLINDER BARREL (2.0 X 8.0)	
2	150-417	1	CYLINDER ROD (1.00 X 8.0)	
	151-076	-	CYL (2.0 X 1.0 X 10.0)	SEE FOOTNOTES 1 & 2
1	152-017	1	CYLINDER BARREL (2.0 X 10.0)	
2	150-444	1	CYLINDER ROD (1.00 X 10.0)	
	149-668	-	CYL (2.0 X 1.0 X 12.0)	SEE FOOTNOTES 1 & 2
1	150-286	1	CYLINDER BARREL (2.0 X 12.0)	
2	149-729	1	CYLINDER ROD (1.00 X 12.0)	
3	150-772	1	CYLINDER HEAD (2.0 X 1.00)	
4	150-778	1	LOCK RING (2.0)	
5	150-775	1	CYLINDER PISTON (2.0 X 1.00)	
6	106-096	1	FLG BOLT (1/2-NC X 1-3/4",GD8)	SEE FOOTNOTE 3
7	157-022	1	O-RING (224 D90)	
8	155-732	1	BACKUP RING (224 D90)	
9	157-540	1	U-SEAL (1.000")	
10	157-537	1	WIPER SEAL (1.000")	
11	125-774	1	WEAR RING	
12	157-534	1	BACKUP RING (131 D90)	
13	157-018	1	O-RING (131 D90)	

NOT SHOWN:

259-100	U-SEAL INSTALLER (1" - 1.499")
259-235	1.00 ROD WIPER TOOL
259-239	WIPER/SEAL INSTALLER (2")
259-241	PISTON INSTALLER (2")
259-188	CYL HEAD SPANNER - TWO PIN

FOOTNOTES:

- REF. #1 & #2 ARE SPECIFIC TO EACH CYLINDER, REF. #3 THRU #13 ARE COMMON FOR ALL THE ABOVE LISTED CYLINDERS
- SEAL REPAIR KIT P/N: 190-165
- APPLY LOCTITE 277 OR EQUIVALENT, TORQUE TO 90-100 FT-LBS

NOTE:

HYDRAULIC CYLINDERS (3.0" X 1.5")

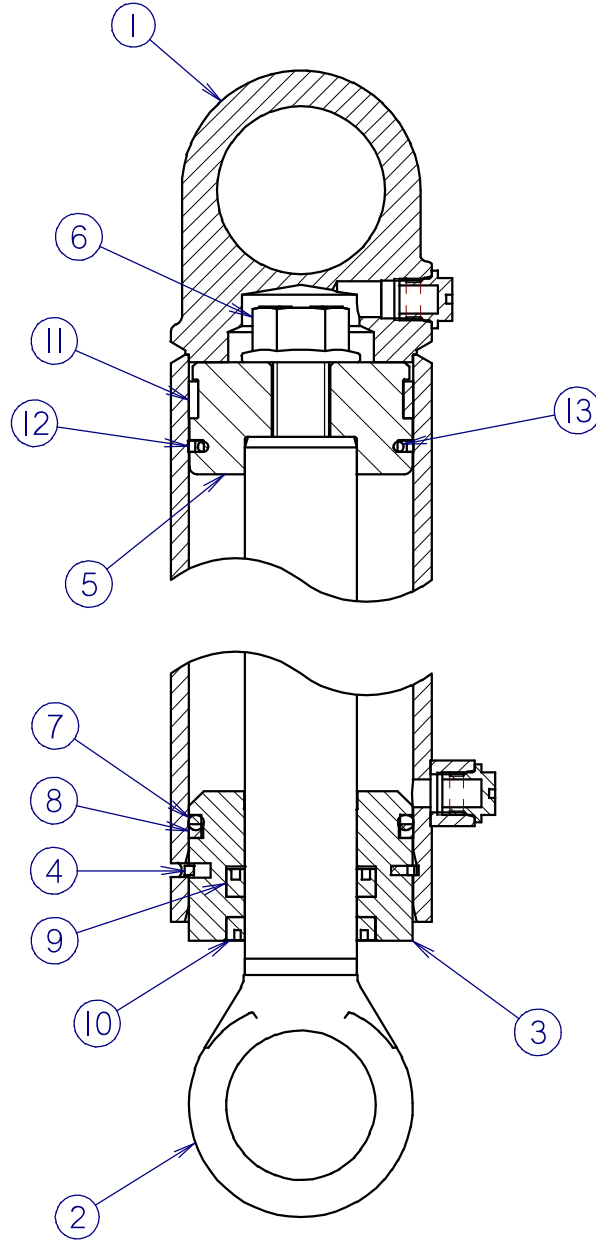

HYDRAULIC CYLINDERS (3.0" X 1.5")

REF NO.	PART NUMBER	QTY	DESCRIPTION	REMARKS
	149-682	-	CYL (3.0 X 1.5 X 2.5)	SEE FOOTNOTES 1 & 2
1	149-804	1	CYLINDER BARREL (3.0 X 2.5)	
2	149-731	1	CYLINDER ROD (1.50 X 2.5)	
	151-049	-	CYL (3.0 X 1.5 X 3.0)	SEE FOOTNOTES 1 & 2
1	150-299	1	CYLINDER BARREL (3.0 X 3.0)	
2	150-431	1	CYLINDER ROD (1.50 X 3.0)	
	151-054	-	CYL (3.0 X 1.5 X 4.0)	SEE FOOTNOTES 1 & 2
1	152-004	1	CYLINDER BARREL (3.0 X 4.0)	
2	150-434	1	CYLINDER ROD (1.50 X 4.0)	
	151-179	-	CYL (3.0 X 1.5 X 5.0)	SEE FOOTNOTES 1 & 2
1	152-068	1	CYLINDER BARREL (3.0 X 5.0)	
2	153-038	1	CYLINDER ROD (1.50 X 5.0)	
	151-086	-	CYL (3.0 X 1.5 X 6.0)	SEE FOOTNOTES 1 & 2
1	152-008	1	CYLINDER BARREL (3.0 X 6.0)	
2	153-003	1	CYLINDER ROD (1.50 X 6.0)	
	151-136	-	CYL (3.0 X 1.5 X 8.0)	SEE FOOTNOTES 1 & 2
1	152-014	1	CYLINDER BARREL (3.0 X 8.0)	
2	153-027	1	CYLINDER ROD (1.50 X 8.0)	
	151-029	-	CYL (3.0 X 1.5 X 10.0)	SEE FOOTNOTES 1 & 2
1	150-284	1	CYLINDER BARREL (3.0 X 10.0)	
2	150-416	1	CYLINDER ROD (1.50 X 10.0)	
	151-043	-	CYL (3.0 X 1.5 X 12.0)	SEE FOOTNOTES 1 & 2
1	150-293	1	CYLINDER BARREL (3.0 X 12.0)	
2	150-426	1	CYLINDER ROD (1.50 X 12.0)	
	151-034	-	CYL (3.0 X 1.5 X 16.0)	SEE FOOTNOTES 1 & 2
1	150-288	1	CYLINDER BARREL (3.0 X 16.0)	
2	150-419	1	CYLINDER ROD (1.50 X 16.0)	
	151-117	-	CYL (3.0 X 1.5 X 20.0)	SEE FOOTNOTES 1 & 2
1	152-054	1	CYLINDER BARREL (3.0 X 20.0)	
2	150-669	1	CYLINDER ROD (1.50 X 20.0)	
3	150-774	1	CYLINDER HEAD (3.0 X 1.50)	
4	150-911	1	LOCK RING (3.0)	
5	150-777	1	CYLINDER PISTON (3.0 X 1.50)	
6	106-098	1	FLG BOLT (3/4-NC X 2", GD8)	SEE FOOTNOTE 3
7	155-734	1	O-RING (334 D90)	
8	155-733	1	BACKUP RING (334 D90)	
9	157-542	1	U-SEAL (1.500")	
10	157-539	1	WIPER SEAL (1.500")	
11	125-776	1	WEAR RING	
12	157-536	1	BACKUP RING (230 D90)	
13	157-020	1	O-RING (230 D90)	

NOT SHOWN:

259-040	U-SEAL INSTALLER (1.5" - UP)
259-237	ROD WIPER INSTALLER (1.5")
259-065	PISTON SEAL INSTALLER (3")
259-066	PISTON INSTALLER (3")
259-188	CYL HEAD SPANNER - TWO PIN

FOOTNOTES:

- REF. #1 & #2 ARE SPECIFIC TO EACH CYLINDER, REF. #3 THRU #13 ARE COMMON FOR ALL THE ABOVE LISTED CYLINDERS.
- SEAL REPAIR KIT P/N: 190-167
- APPLY LOCTITE 277 OR EQUIVALENT, TORQUE TO 290-325 FT-LBS

NOTE:

HYDRAULIC CYLINDERS (3.5" X 1.75")

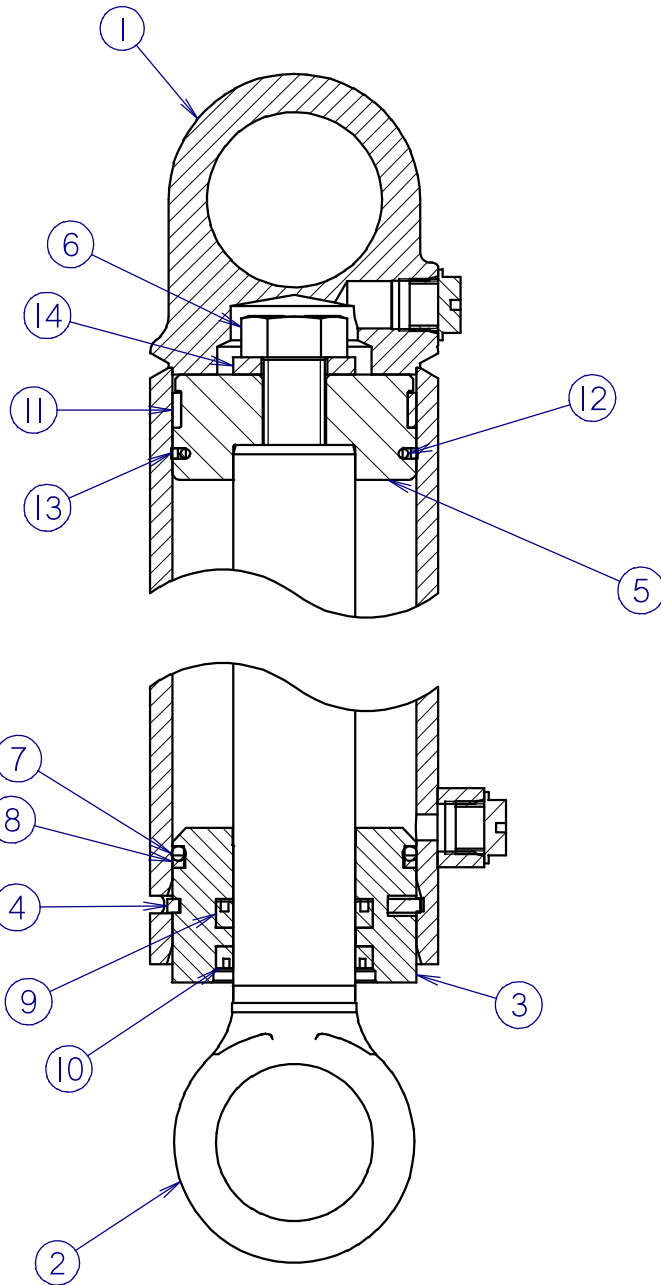

HYDRAULIC CYLINDERS (3.5" X 1.75")

REF NO.	PART NUMBER	QTY	DESCRIPTION	REMARKS
	151-089	-	CYL (3.5 X 1.75 X 3.0)	SEE FOOTNOTES 1 & 2
1	152-025	1	CYLINDER BARREL (3.5 X 3.0)	
2	150-446	1	CYLINDER ROD (1.75 X 3.0)	
	151-112	-	CYL (3.5 X 1.75 X 4.0)	SEE FOOTNOTES 1 & 2
1	152-037	1	CYLINDER BARREL (3.5 X 4.0)	
2	153-015	1	CYLINDER ROD (1.75 X 4.0)	
	151-050	-	CYL (3.5 X 1.75 X 5.0)	SEE FOOTNOTES 1 & 2
1	150-300	1	CYLINDER BARREL (3.5 X 5.0)	
2	150-432	1	CYLINDER ROD (1.75 X 5.0)	
	151-046	-	CYL (3.5 X 1.75 X 6.0)	SEE FOOTNOTES 1 & 2
1	150-296	1	CYLINDER BARREL (3.5 X 6.0)	
2	150-428	1	CYLINDER ROD (1.75 X 6.0)	
	151-056	-	CYL (3.5 X 1.75 X 8.0)	SEE FOOTNOTES 1 & 2
1	152-006	1	CYLINDER BARREL (3.5 X 8.0)	
2	150-436	1	CYLINDER ROD (1.75 X 8.0)	
	149-689	-	CYL (3.5 X 1.75 X 10.0)	SEE FOOTNOTES 1 & 2
1	152-040	1	CYLINDER BARREL (3.5 X 10.0)	
2	149-732	1	CYLINDER ROD (1.75 X 10.0)	
	151-069	-	CYL (3.5 X 1.75 X 12.0)	SEE FOOTNOTES 1 & 2
1	150-297	1	CYLINDER BARREL (3.5 X 12.0)	
2	150-425	1	CYLINDER ROD (1.75 X 12.0)	
	149-799	-	CYL (3.5 X 1.75 X 16.0)	SEE FOOTNOTES 1 & 2
1	149-805	1	CYLINDER BARREL (3.5 X 16.0)	
2	153-004	1	CYLINDER ROD (1.75 X 16.0)	
	149-690	-	CYL (3.5 X 1.75 X 20.0)	SEE FOOTNOTES 1 & 2
1	149-765	1	CYLINDER BARREL (3.5 X 20.0)	
2	153-020	1	CYLINDER ROD (1.75 X 20.0)	
	149-691	-	CYL (3.5 X 1.75 X 24.0)	SEE FOOTNOTES 1 & 2
1	149-766	1	CYLINDER BARREL (3.5 X 24.0)	
2	149-733	1	CYLINDER ROD (1.75 X 24.0)	
3	150-761	1	CYLINDER HEAD (3.5 x 1.75)	
	149-302	1	LOCK RING (3.5)	
5	149-301	1	CYLINDER PISTON (3.5 X 1.75)	
6	106-122	1	BOLT (7/8-NC X 2-1/4", GD8)	SEE FOOTNOTE 3
7	157-030	1	O-RING (338 D90)	
8	157-032	1	BACKUP RING (338 D90)	
9	157-550	1	U-SEAL (1.750")	
10	157-549	1	WIPER SEAL (1.750")	
11	125-784	1	WEAR RING	
12	157-031	1	O-RING (234 D90)	
13	157-554	1	BACKUP RING (234 D90)	
14	105-363	1	WASHER (7/8")	

NOT SHOWN:

259-040	U-SEAL INSTALLER (1.5" - UPI)
259-238	WIPER INSTALLER (1.75")
259-244	PISTON SEAL INSTALLER (3.5")
259-245	PISTON INSTALLER (3.5")
259-188	CYL HEAD SPANNER - TWO PIN

FOOTNOTES:

- REF. #1 & #2 ARE SPECIFIC TO EACH CYLINDER, REF. #3 THRU #14 ARE COMMON FOR ALL THE ABOVE LISTED CYLINDERS.
- SEAL REPAIR KIT P/N: 190-174
- APPLY LOCTITE 277 OR EQUIVALENT, TORQUE TO 410-460 FT-LBS

NOTE:

HYDRAULIC CYLINDER 3.5" X 1.75" X 2.0"

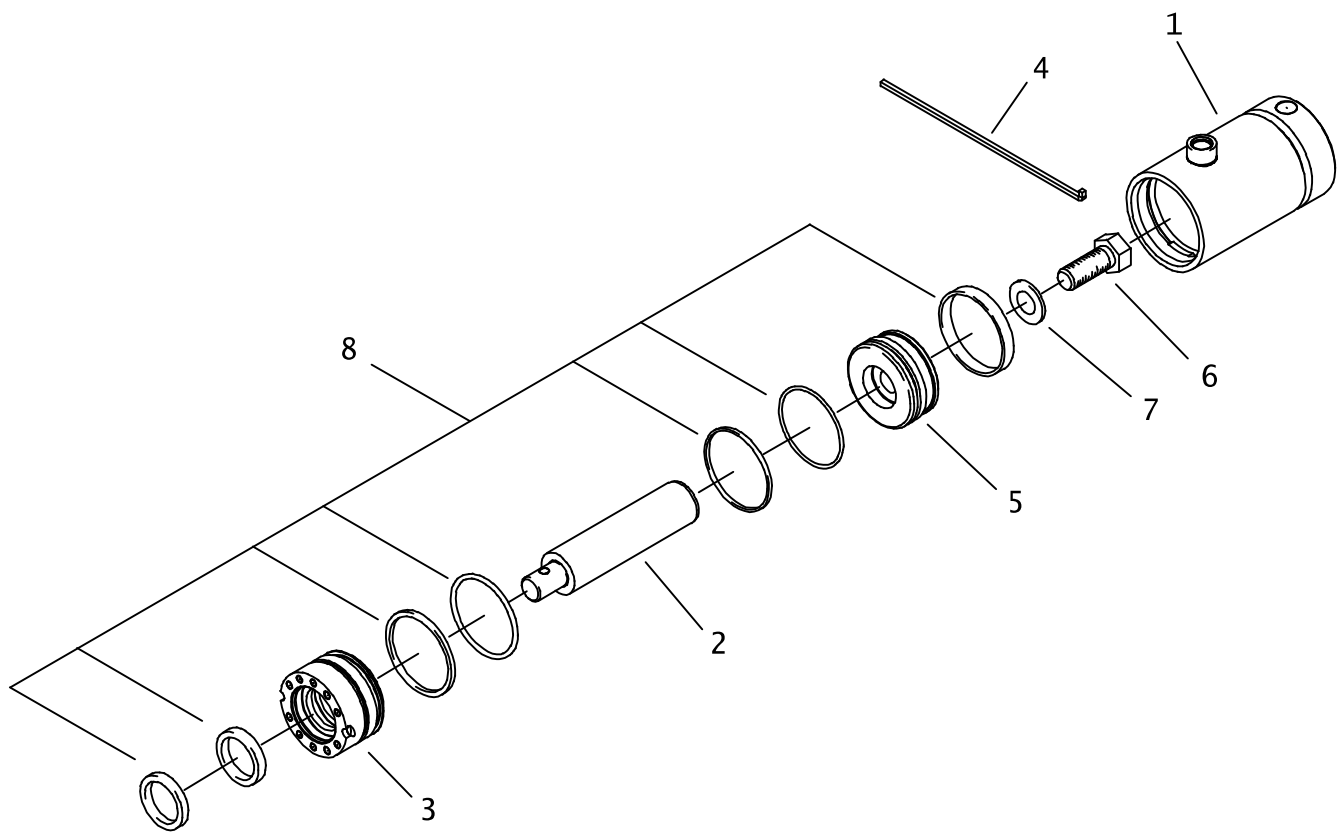

HYDRAULIC CYLINDER 3.5" X 1.75" X 2.0"

REF NO.	PART NUMBER	QTY	DESCRIPTION	REMARKS
	151-213	-	CYL (3.5 X 1.75 X 2.0)	INCL REF NO.'S 1 THRU 15
1.	153-849	1	BARREL	
2.	153-845	1	CYL ROD	
3.	153-846	1	CYLINDER GLAND	
4.	149-302	1	LOCK RING (3.5")	
5.	149-301	1	CYL PISTON (3.5" X 1.75")	
6.	106-122	1	BOLT (7/8-NC X 2-1/4", GD8)	SEE FOOTNOTE 1
7.	105-363	1	WASHER (7/8")	
8.	190-174	1	SEAL REPAIR KIT	

NOT SHOWN:

FOOTNOTES:

- I. LUBRICATE WITH WD-40 OR EQUAL TORQUE TO 410-460 FT LBS (566-624 NM)

NOTE:

ANCHOR SYSTEMS

ANCHOR SYSTEM

ENDS WITH S/N: CMWJ1220H60000135

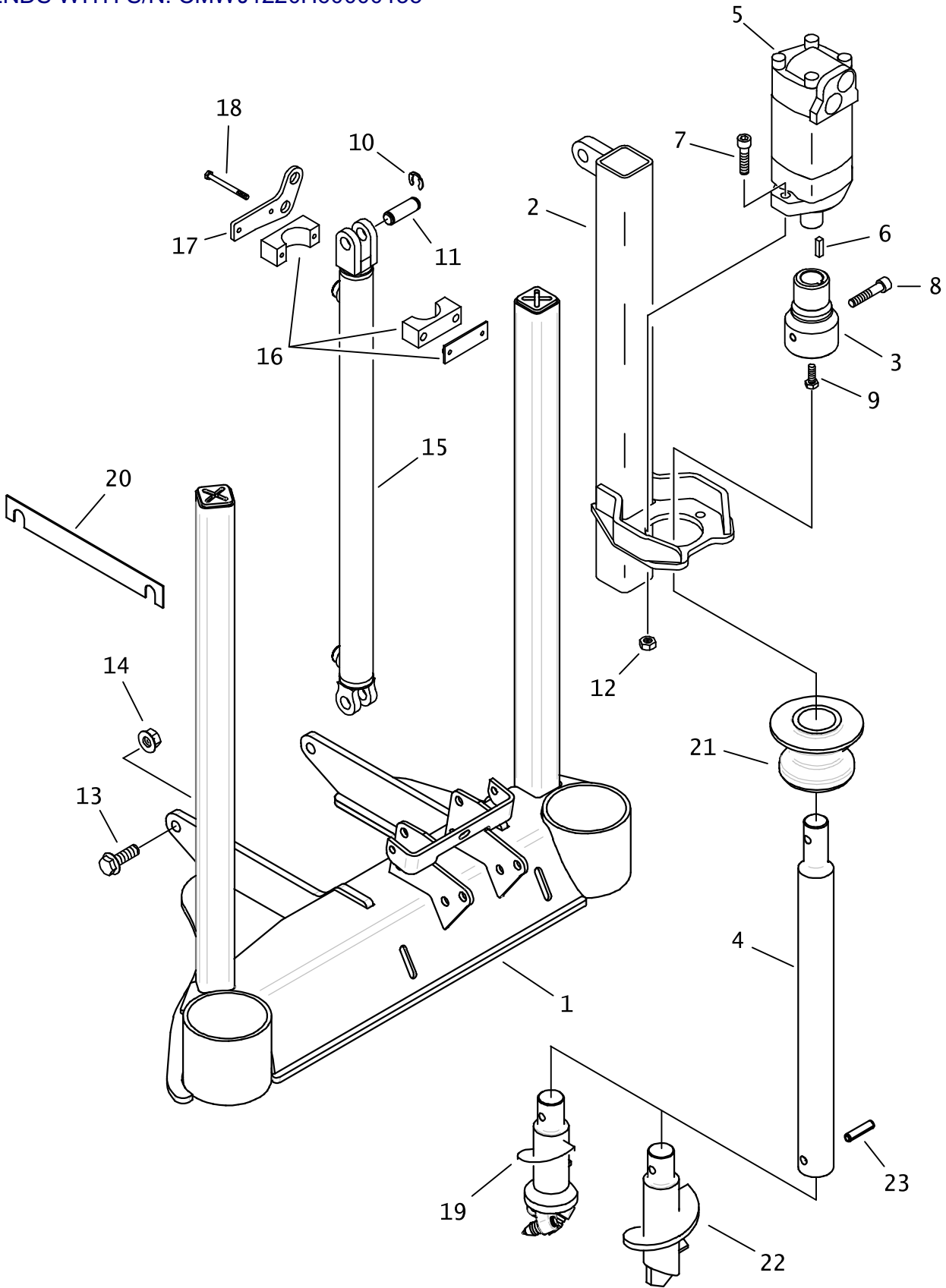

ANCHOR SYSTEM

ENDS WITH S/N: CMWJ1220H60000135

REF NO.	PART NUMBER	QTY	DESCRIPTION	REMARKS
1.	329-291	1	ANCHOR FRAME	
2.	316-767	2	UPPER TUBE	
3.	316-801	2	ANCHOR DRIVER	
4.	166-605	2	SHAFT	
5.	158-700	2	HYD MOTOR	INCL. REF #6
	500-658	-	SEAL REPAIR KIT	
	166-278	-	SHAFT ASSEMBLY	
6.	165-909	-	KEY (5/16" X 1-1/8")	
7.	106-707	4	SCREW (M12-1.75 X 45MM, SOC)	
8.	106-771	2	SCREW (M12-1.75 X 60MM, SOC)	
9.	105-052	2	BOLT (3/8-NC X 1-1/4")	
10.	115-503	8	KLIP RING (.750")	
11.	179-736	4	PIN	
12.	106-685	4	LOCKNUT(M12-1.75,PRV TRQ,10.9)	
13.	107-336	4	FLG SCREW (M16-2.00X45MM,10.9)	
14.	106-355	4	FLG NUT (M16-2.00, 10.9)	
15.	151-214	2	HYD CYL	
16.	318-631	2	BOLT-ON CLAMP (1.88")	
17.	318-658	2	BULKHEAD BRACKET	
18.	107-196	4	BOLT (1/4-NC X 3")	
19.	327-457	-	ROCK ANCHOR	
	131-259	-	INSERT BIT - CARBIDE TIPPED	
20.	118-386	AR	SHIM	
21.	158-238	2	CENTERING CAP	
22.	327-460	-	AUGER (4")	
23.	107-331	2	ROLL PIN (M12 X 50MM)	

NOT SHOWN:

FOOTNOTES:

NOTE:

ANCHOR SYSTEM

BEGINS WITH S/N: CMWJ1220E60000136

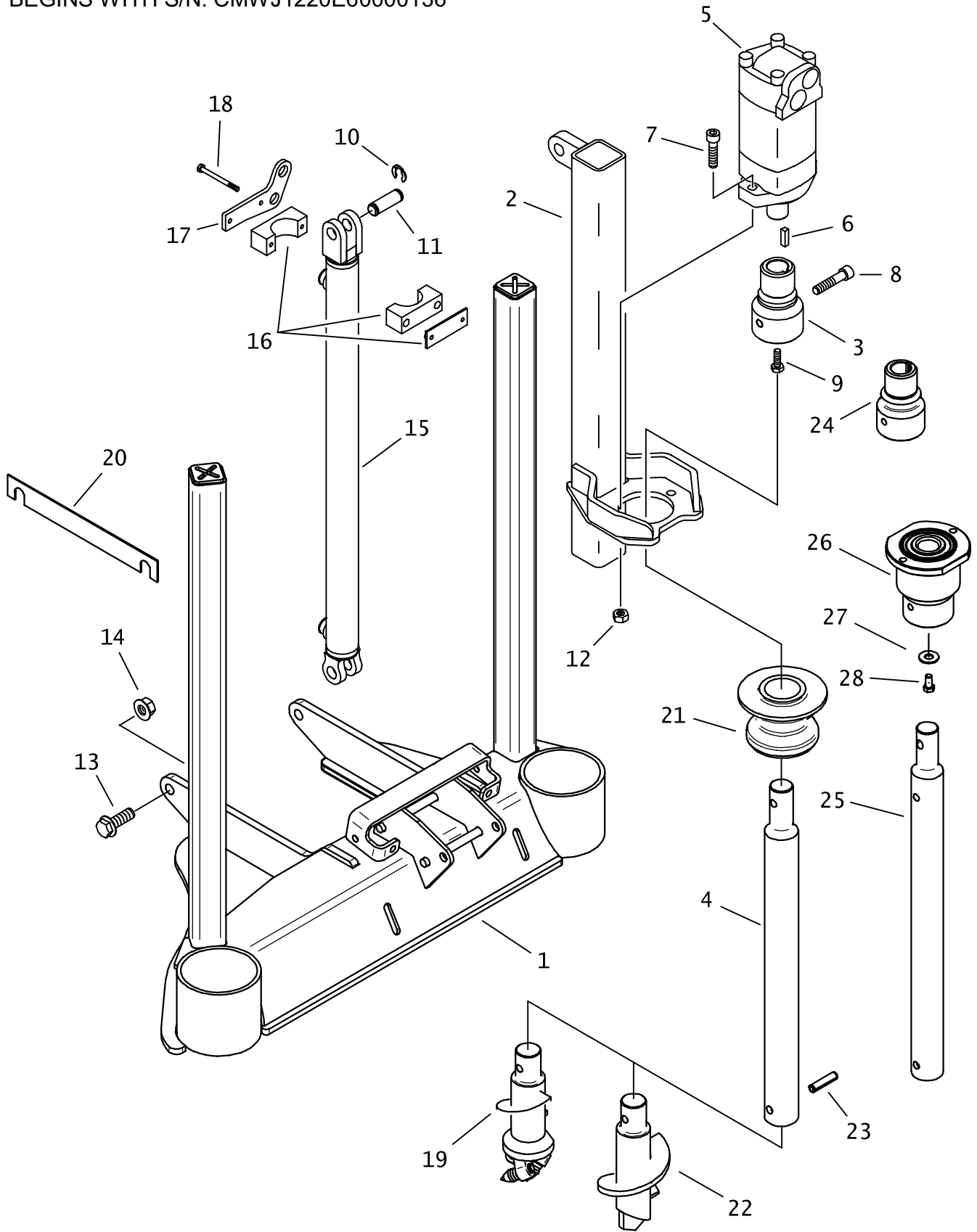

ANCHOR SYSTEM

BEGINS WITH S/N: CMWJ1220E60000136

REF NO.	PART NUMBER	QTY	DESCRIPTION	REMARKS
1.	300-2951	1	ANCHOR FRAME	
2.	316-767	2	UPPER TUBE	
3.	<u>316-801</u>	2	ANCHOR DRIVER	SUPERSEDED WITH : 327-499; ITEM #24
4.	166-605	2	SHAFT (OLD STYLE)	SUPERSEDED WITH : 166-617; ITEM #25
5.	158-700	2	HYD MOTOR	INCL. REF #6
	500-658	-	SEAL REPAIR KIT	
	166-278	-	SHAFT ASSEMBLY	
6.	165-909	-	KEY (5/16" X 1-1/8")	
7.	106-707	4	SCREW (M12-1.75 X 45MM, SOC)	
8.	106-771	2	SCREW (M12-1.75 X 60MM, SOC)	
9.	105-156	2	BOLT (3/8-NC X 1-1/2")	NOT USED WITH 350-2174
10.	115-503	8	KLIP RING (.750")	
11.	179-736	4	PIN	
12.	106-685	4	LOCKNUT(M12-1.75, PRV TRQ, 10.9)	NOT USED WITH 350-2174
13.	107-336	6	FLG SCREW (M16-2.00X45MM, 10.9)	
14.	106-355	6	FLG NUT (M16-2.00, 10.9)	
15.	151-214	2	HYD CYL	
	500-1542	-	SEAL KIT	
16.	318-631	2	BOLT-ON CLAMP (1.88")	
17.	318-658	2	BULKHEAD BRACKET	
18.	107-196	4	BOLT (1/4-NC X 3")	
19.	327-457	-	ROCK ANCHOR	
	131-259	-	INSERT BIT - CARBIDE TIPPED	
20.	118-386	AR	SHIM	
21.	158-238	2	CENTERING CAP	
22.	327-460	-	AUGER (4")	
23.	107-331	2	ROLL PIN (M12 X 50MM)	
24.	<u>327-499</u>	2	ANCHOR DRIVER (NEW STYLE)	SUPERSEDED WITH: 350-2174; ITEM #26
25.	166-617	2	ANCHOR SHAFT	
26.	350-2174	2	ANCHOR DRIVE COUPLER	USED WITH 350-2174
27.	105-794	2	WASHER (M12)	USED WITH 350-2174
28.	105-825	2	FLG LK BOLT (3/8-NC X 3/4")	

NOT SHOWN:

FOOTNOTES:

NOTE:

ANCHOR VALVE/LUBRICATOR MOUNT

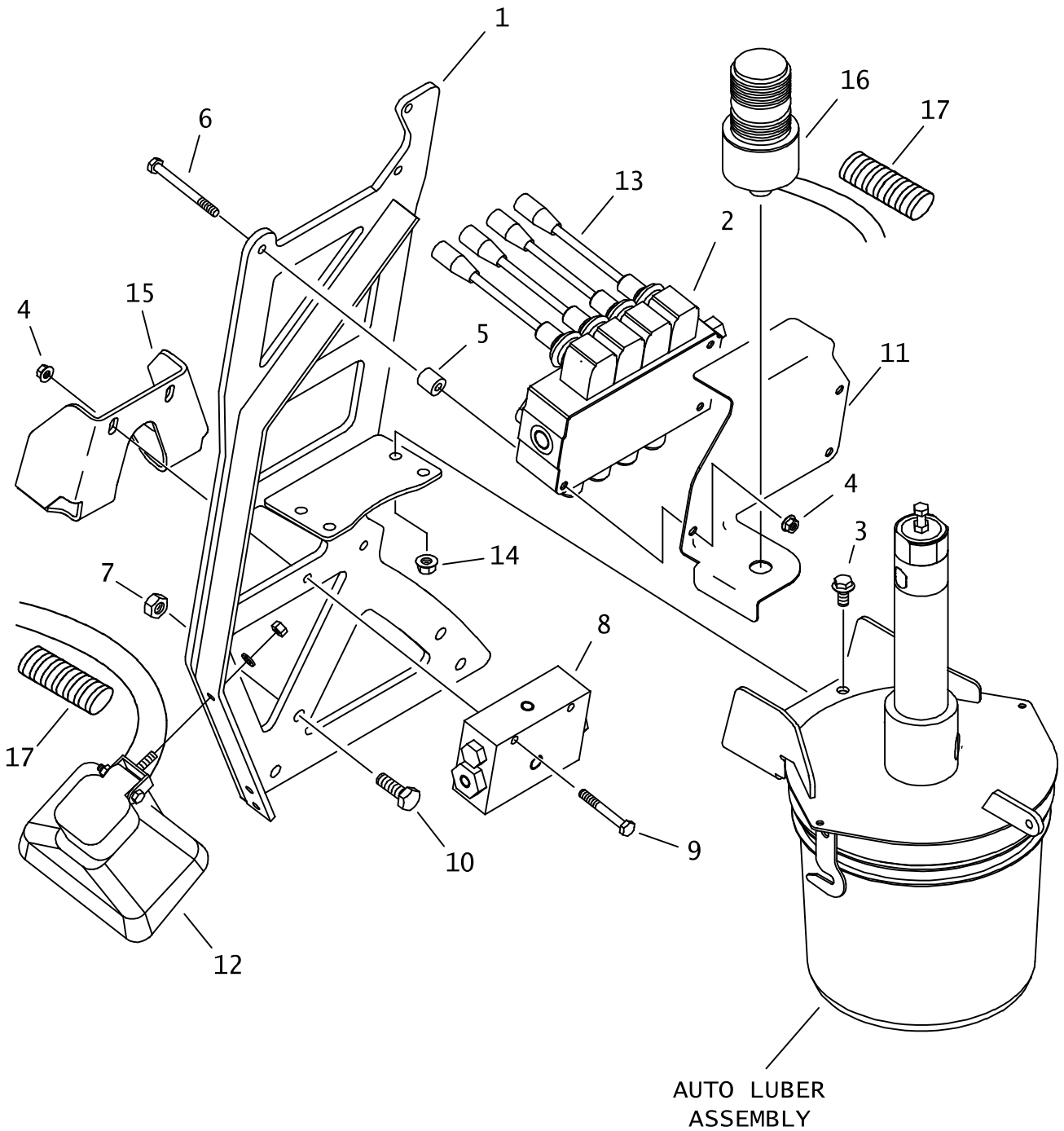

ANCHOR VALVE/LUBRICATOR MOUNT

REF NO.	PART NUMBER	QTY	DESCRIPTION	REMARKS
1.	316-861	1	MOUNT	
2.	157-241	1	ANCHOR VALVE	
3.	106-382	4	FLG LK SCREW (M10-1.50 X 20MM)	
4.	106-386	5	FLG LOCKNUT (M8-1.25)	
5.	179-501	3	SPACER	
6.	107-078	3	SCREW (M8-1.25 X 90MM)	
7.	106-709	4	FLG LK NUT (M12-1.75)	
8.	310-591	1	VALVE	
9.	106-330	2	SCREW (M8-1.25 X 70MM)	
10.	106-333	4	SCREW (M12-1.75 X 40MM, 8.8)	
11.	319-330	1	LIGHT MOUNT	
12.	217-057	1	WORKING LIGHT - CLEAR	
	157-645	2	WEATHER-PAC SEAL (2.80MM)	
	214-103	1	(2-WAY) MALE CONNECTOR	
	214-104	2	PACKARD MALE TERMINAL	
13.	500-908	4	LEVER (M8-1.25, BLACK)	
14.	106-387	4	FLG LOCKNUT (M10-1.50)	
15.	323-513	1	BRACE	FOR USE ON JT1220
	325-281	1	BRACE	FOR USE ON JT2020
16.	217-297	1	STROBE LIGHT GREEN MED PROFILE	
	214-103	1	(2-WAY) MALE CONNECTOR	
	214-104	2	PACKARD MALE TERMINAL	
	157-645	2	WEATHER-PAC SEAL (2.80MM)	
17.	216-026	AR	FLEX-GUARD (.25")	SOLD PER IN. & USE 2 @ 15" EACH

NOT SHOWN:

FOOTNOTES:

NOTE:

GREASE PUMP

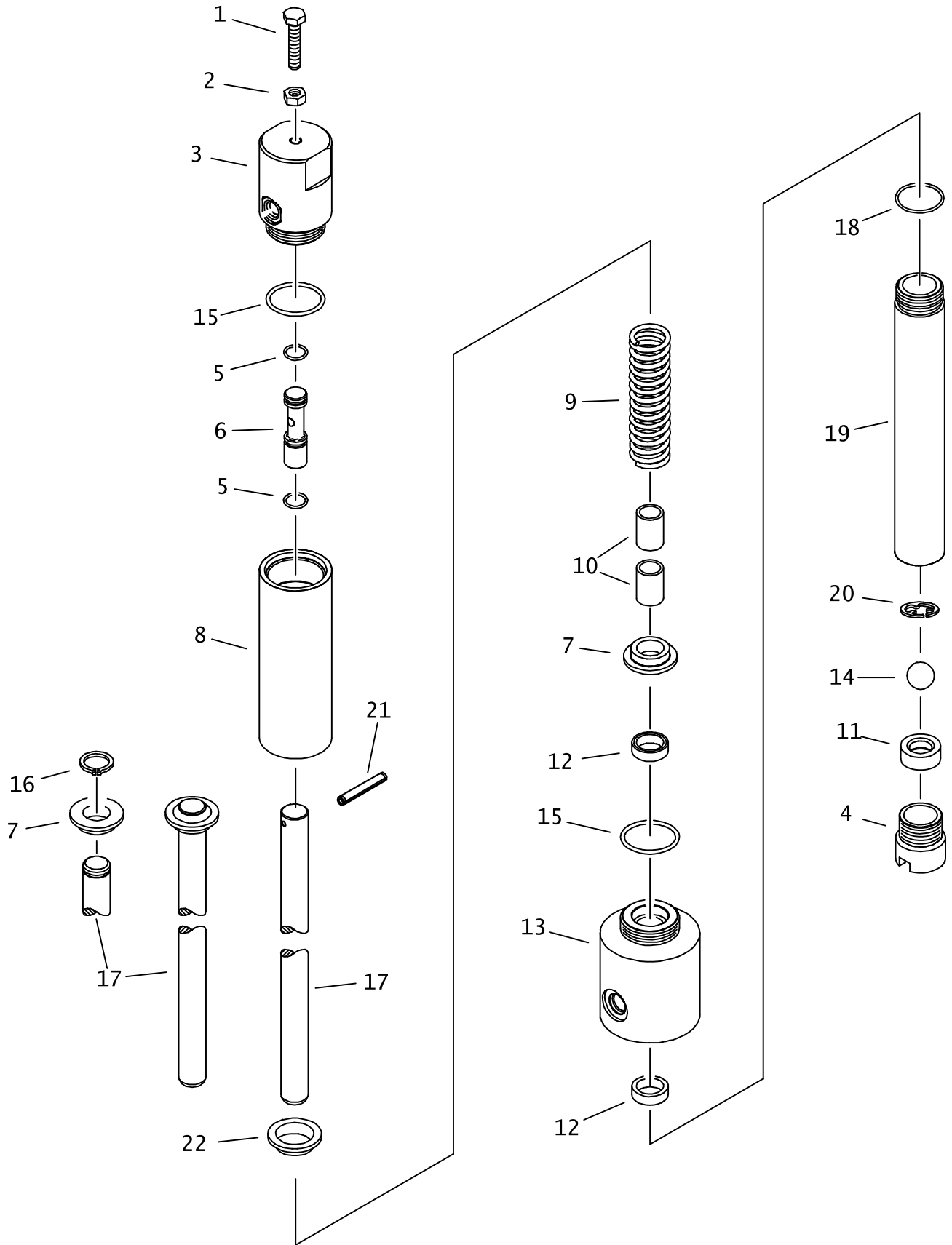

GREASE PUMP

REF NO.	PART NUMBER	QTY	DESCRIPTION	REMARKS
	350-398		GREASE PUMP PARTS	INCL REF NO'S 1-20
1.	107-492	1	SCREW (M8-1.25 X 35MM, ALL THD)	
2.	106-078	1	NUT (M8-1.25)	
3.	350-686	1	CYLINDER CAP	
4.	350-692	1	INLET TUBE	
5.	157-049	2	O-RING (113 D70)	
6.	350-421	1	ADJUSTING SPOOL	
7.	350-671	1	ROD GUIDE	SEE FOOTNOTE 2
8.	350-682	1	BARREL	
9.	117-228	1	COMPRESSION SPRING	
10.	125-424	2	BRONZE BUSHING (.750")	
11.	350-691	1	VALVE SEAT	SEE FOOTNOTE 1
12.	117-227	2	SEAL (POLY PAK)	
13.	350-687	1	PUMP BODY	
14.	125-125	1	DETENT BALL (.750")	
15.	155-702	2	O-RING (920 D90)	
16.	117-226	-	EXTERNAL SNAP RING (.750")	SEE FOOTNOTE 2
	115-545	-	EXTERNAL SNAP RING (.75")	
17.	350-689	-	PLUNGER	SEE FOOTNOTE 2
	308-603	-	PLUNGER	SEE FOOTNOTE 3
	166-280	1	PLUNGER	
18.	155-748	1	O-RING (916 D90)	
19.	350-693	1	PUMP BARREL	
20.	301-0196	1	RETAINER CLIP	SEE FOOTNOTE 4
21.	105-525	1	ROLL PIN (3/16" X 1/4")	SEE FOOTNOTE 3
22.	178-467	1	ROD CAP	SEE FOOTNOTE 3

NOT SHOWN:

FOOTNOTES:

1. INSTALL WITH SMALLER BEVEL TOWARD INSIDE OF PUMP
2. 308-603 PLUNGER IS A DIRECT REPLACEMENT OF 350-689 PLUNGER, 117-226 RETAINER RING, AND AN ADDITIONAL 350-671 ROD GUIDE.
3. USE 166-280, 178-467 & 105-525 TO SUPERSEDE 308-603
4. RETAINER CLIP 301-0196 SUPERSEDES CLIP 105-653

NOTE:

LUBRICATOR VALVE

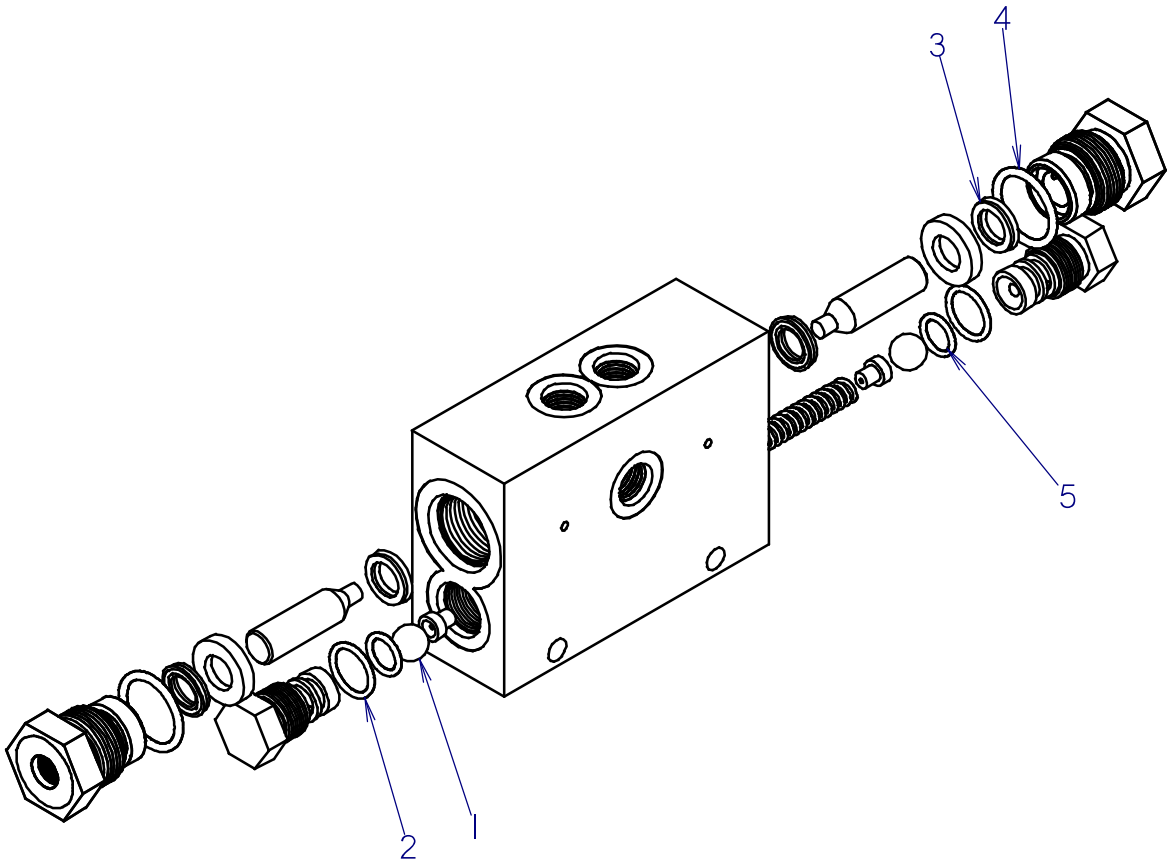

LUBRICATOR VALVE

REF NO.	PART NUMBER	QTY	DESCRIPTION	REMARKS
	310-591	1	VALVE	
1	125-084	2	DETENT BALL (.500)	
2	155-706	2	O-RING (908 D90)	
3	116-880	2	SEAL (POLY PAK)	
4	155-709	2	O-RING (912 D90)	
5	157-098	2	O-RING (111 D70)	

FOOTNOTES

NOTE:

LUBRICATOR NOZZLE AND APPLICATOR

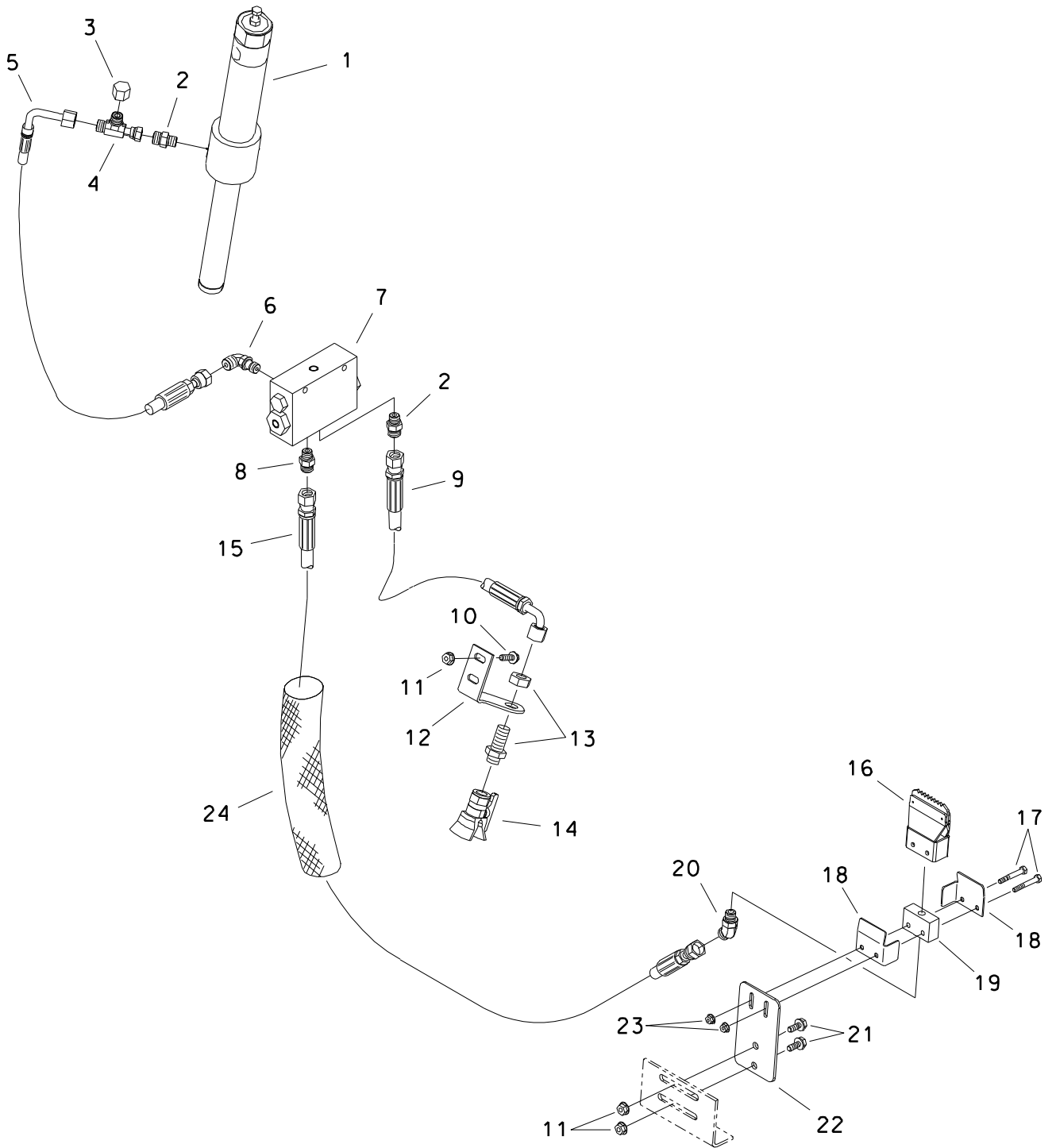

LUBRICATOR NOZZLE AND APPLICATOR

REF NO.	PART NUMBER	QTY	DESCRIPTION	REMARKS
1.	350-398	-	GREASE PUMP PARTS	
2.	154-221	2	CONNECTOR (06S-060)	
3.	154-326	1	CAP (060F)	
4.	154-344	1	UN RUN TEE (060FX-060-060)	
5.	157-928	1	HOSE (060FX90L-19"3000)	
6.	154-342	1	CONNECTOR (06S-06090)	
7.	310-591	-	VALVE	
8.	514-165	1	CONNECTOR (06S-060, DRF .078")	
9.	515-376	1	HOSE (060FX90-13"-3000)	
	153-585	-	HOSE (060FX-18"-3000, SPCL)	SEE FOOTNOTE 1
10.	106-381	2	FLG LK SCREW (M8-1.25 X 25MM)	
11.	106-386	4	FLG LOCKNUT (M8-1.25)	
12.	318-409	1	NOZZLE BRACKET	
13.	514-163	1	BK CONNECTOR (060-060BK)	
14.	149-399	1	SPRAY NOZZLE (65)	
15.	157-929	1	HOSE (060FX-174"3000)	
16.	306-423	1	WIPER PARTS ASS'Y	
	116-937	1	APPLICATOR	
	107-394	4	WASHER (.375", ALUMINUM)	
	107-395	2	RIVET (.156 X .500) SEMI-TUBUL	
17.	106-093	2	SCREW (M6-1.00 X 45MM)	
18.	305-911	2	BRACKET, APPLICATOR	
19.	305-912	1	BASE, APPLICATOR	
20.	514-414	1	CONNECTOR (04S-06045)	
21.	106-162	2	FLG SCREW (M8-1.25 X 20MM)	
22.	316-954	1	APPLICATOR MOUNT PLATE	
23.	106-385	2	FLG LOCKNUT (M6-1.00)	
24.	117-987	1	ABRASION SLEEVE (1.00" X 174")	

FOOTNOTES

1- HEATED HOSE, REQUIRES 154-228 UNION (060-060FX90)

AUTO-LUBER ASSEMBLY

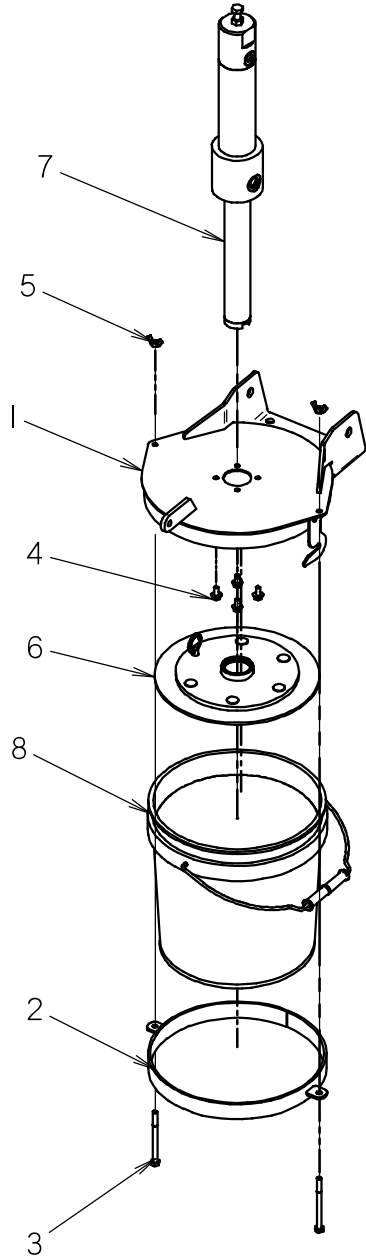

AUTO-LUBER ASSEMBLY

REF NO.	PART NUMBER	QTY	DESCRIPTION	REMARKS
1	350-400	1	COVER WELDMENT	
2	350-399	1	BASE	
3	105-297	2	BOLT (1/4-NC X 3-1/4")	
4	106-378	4	FLG LK SCREW (M6-1.00 X 12MM)	
5	195-339	2	WING NUT (1/4-NC)	
6	350-1932	1	TOOL JOINT LUBE FOLLOWER	
7	350-398	1	GREASE PUMP PARTS	
8	259-858	1	TOOL JNT LUBE, STD SPRY 2 GAL	
	256-031	-	TOOL JNT LUBE, SUMR SPRY 2 GAL	

NOT SHOWN:

FOOTNOTES:

NOTE:

FLUID SYSTEMS

DRILLING FLUID PUMP

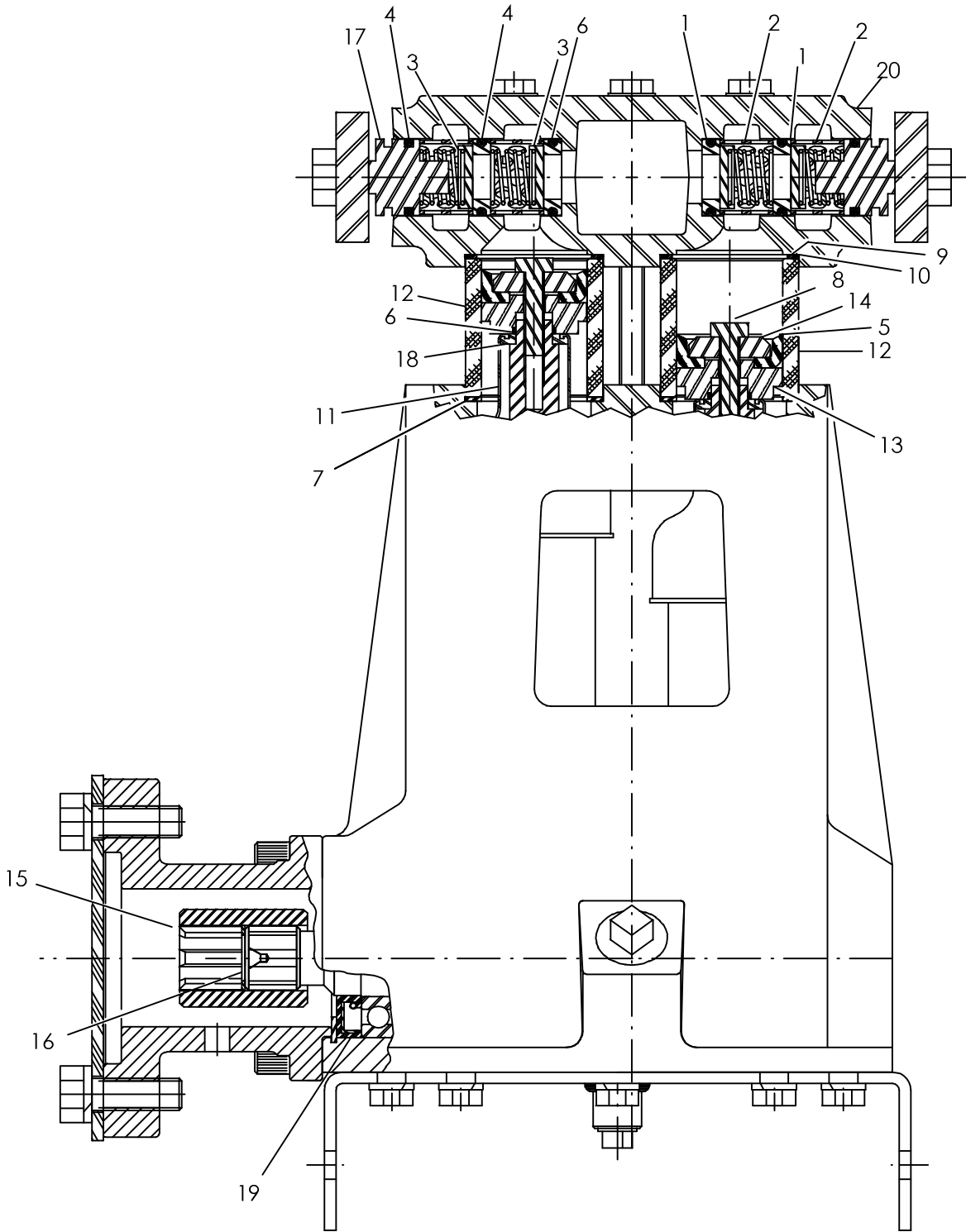

DRILLING FLUID PUMP

REF NO.	PART NUMBER	QTY	DESCRIPTION	REMARKS
	157-267	1	DRILLING FLUID PUMP	
	197-115	-	REMANUFACTURED 157-267 PUMP	
	191-023	1	VALVE REPAIR KIT	INCLUDES REF NO.'S 1-4
	191-034	1	PACKING REPAIR KIT	INCLUDES REF NO.'S 5-10
1.	N/A	8	VALVE SEAT	
2.	N/A	8	CAGE	
3.	N/A	8	DISC AND SPRING	
4.	N/A	12	O-RING	
5.	N/A	4	CUP	
6.	N/A	4	O-RING	
7.	N/A	4	CYLINDER GASKET	
8.	N/A	4	HEX HD CAP SCREW (5/16-18 x 1 1/2" LG)	
9.	N/A	4	SEAL RING	
10.	157-159	4	O-RING (033 D90)	
11.	499-045	4	UMBRELLA SEAL	
12.	499-058	4	CERAMIC CYLINDER (1-3/8")	
13.	499-059	4	PACKING HOLDER	
14.	499-060	4	PACKING WASHER	
15.	499-066	1	COUPLER	PUMP TO DRIVE MOTOR USED ON EARLIER MODELS
16.	499-067	1	RETAINING RING	
	500-2012	1	SPRING PIN 3/32" x 1.5"	
17.	499-086	4	VALVE COVER	
18.	499-087	4	UMBRELLA WASHER	
19.	157-751	4	SEAL, CRANKSHAFT	
20.	499-825	1	FLUID CYLINDER	

NOT SHOWN:

FOOTNOTES:

NOTE:

DRILLING FLUID PUMP PLUMBING

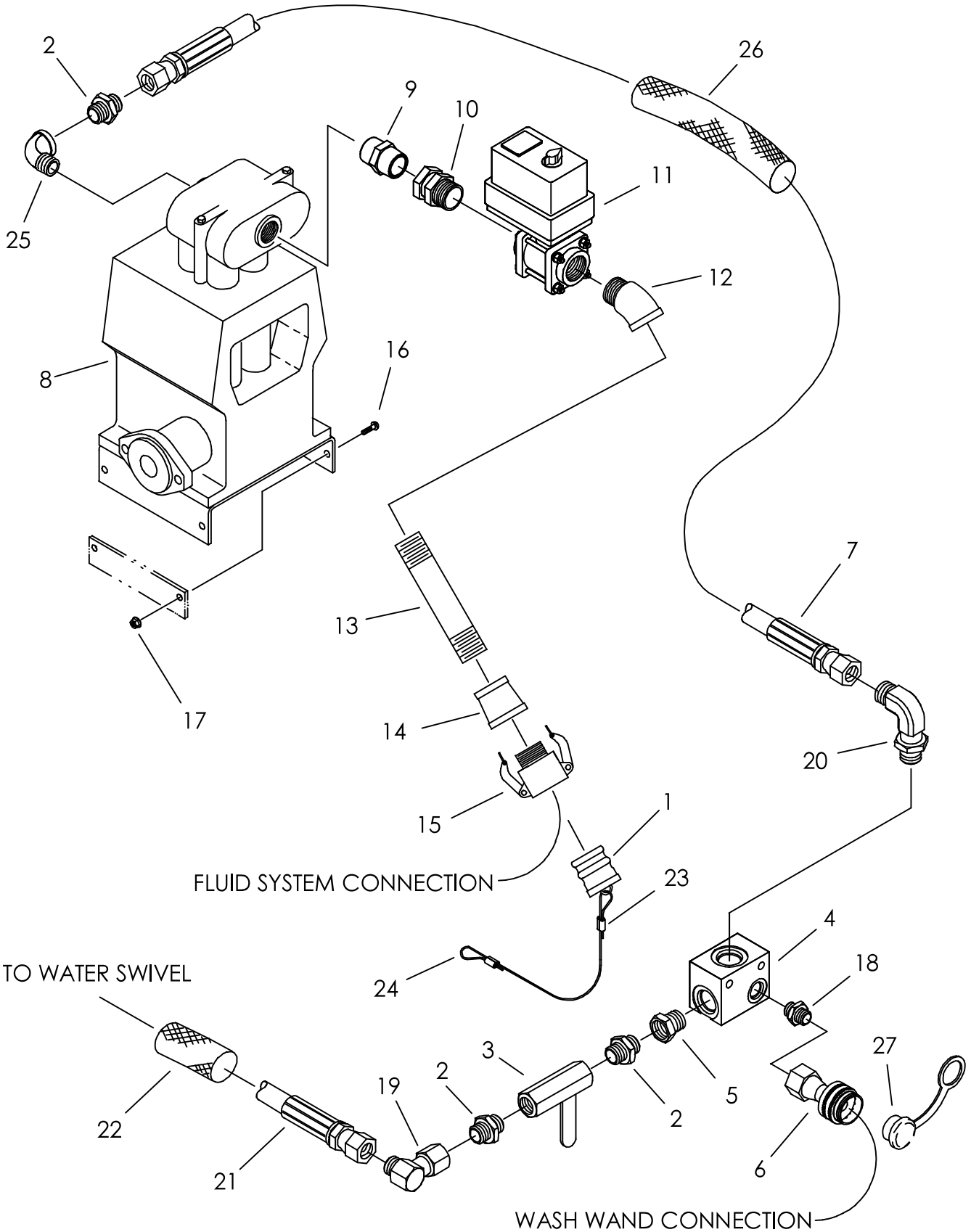

DRILLING FLUID PUMP PLUMBING

REF NO.	PART NUMBER	QTY	DESCRIPTION	REMARKS
1.	110-630	1	DUST PLUG (1-1/2")	
2.	154-102	3	CONNECTOR (12N-12J)	
3.	120-073	1	SHUT OFF (12NF-12NF)	
4.	159-791	1	HYDRAULIC MANIFOLD BLOCK	
5.	154-144	1	UNION (12S-12JFX)	
6.	159-088	1	QDC BODY (08-08SF)	
	155-936	1	DUST PLUG (1/2" - 3/4")	
7.	159-579	1	HOSE (12JFX-30"-1500)	
8.	157-267	1	DRILLING FLUID PUMP	
9.	105-1558	1	PIPE NIPPLE -20 NPT	
10.	155-185	1	UNION (20NF-20N)	
11.	159-522	1	BALL VALVE, ELECTRIC (1-1/4")	SEE FOOTNOTE I
	190-1068	-	SEAT/O-RING REPAIR KIT	
	215-224	1	3 WAY WP MALE CONNECTOR	
	214-104	3	PACKARD MALE TERMINAL	
	157-645	3	WEATHER-PACK SEAL (2.80mm)	
	500-1337	1	1" FLANGE CLAMP	
	500-1339	1	EV MOTOR	
	500-1340	1	WEEP HOLE FILTER	
	159-575	1	STREET ELBOW (20N-20NF45)	
13.	150-2200	1	NIPPLE (20N-10")	
14.	514-124	1	SWAGE COLLAR (24NF-20NF,4.5")	
15.	159-500	1	FHC BODY (24-24N)	
16.	106-383	4	FLG LK SCREW (M10-1.50 X 30mm)	
17.	106-387	4	FLG LOCKNUT (M10-1.50)	
18.	154-466	1	CONNECOTR (08S-08S)	
19.	154-026	1	UNION (12J-12JFX90)	
20.	154-014	1	CONNECTOR (12J-12S90)	
21.	154-617	-	HOSE (12JFX-95"-2250)	
22.	117-655	1	ABRASION SLEEVE (1.59" X 38")	
23.	350-275	2	ALUMINUM SLEEVE (1/16")	
24.	110-981	-	AR BULK CABLE (1/16",SOLD PER FT)	USE 12"
25.	115-120	1	STR ELB (12N-12NF90-2000PSI)	
26.	115-754	1	ABRASION SLEEVE (1.59" X 30")	
27.	155-936	1	DUST PLUG (1/2" - 3/4")	

NOT SHOWN:

FOOTNOTES:

I. ORDER P/N 500-1338 FOR BALL VALVE REPLACEMENT.

NOTE:

REFER TO O-RING CHART 800-301 FOR REPLACEMENT O-RINGS.

DRILLING FLUID PLUMBING

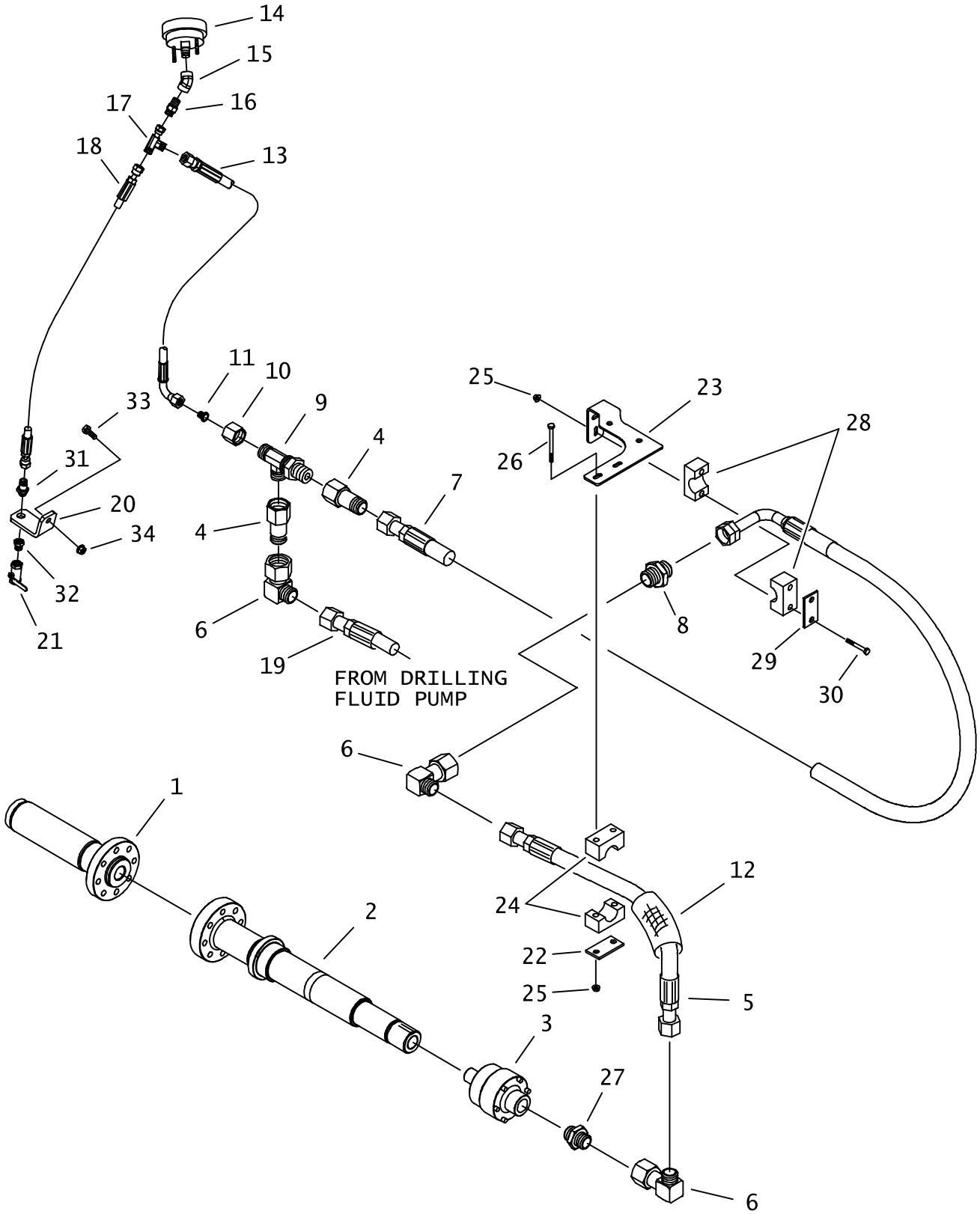

DRILLING FLUID PLUMBING

REF NO.	PART NUMBER	QTY	DESCRIPTION	REMARKS
1.	400-604	-	SAVER SUB 1.73-4F DS	
2.	166-426	-	SLIDING OUTPUT SHAFT	
3.	153-242	-	WATER SWIVEL (12NF-12NF)	
	191-248		SEAL KIT	
4.	514-047	2	UNION (12J-120FX)	
5.	159-579	1	HOSE (12JFX-30"-1500)	
6.	154-026	3	UNION (12J-12JFX90)	
7.	157-969	1	HOSE (12JFX90L-119"-1500)	
8.	154-101	1	CONNECTOR (12J)	
9.	514-002	1	BK RUN TEE (120)	
10.	154-271	1	REDUCER NUT (120F)	
11.	154-282	1	REDUCER STEM (040)	
12.	115-754	1	ABRASION SLEEVE (1.59" X 30")	
13.	515-030	1	HOSE (040FX90S-64"-3000)	
14.	258-046	-	PRESSURE GAUGE (1500PSI)	
	150-1444	-	PRESSURE GAUGE (2000PSI)	
15.	514-418	1	ELBOW (04NF-04NF45)	
16.	154-339	1	CONNECTOR (04N-040)	
17.	154-265	1	UNION RUN TEE (040FX-040-040)	
18.	515-072	1	HOSE (040FX45-16"-3000)	
19.	154-617	1	HOSE (12JFX-95"-2250)	
20.	320-599	1	VALVE BRACKET	
21.	120-071	1	SHUT-OFF (04NF-04NF)	
22.	322-362	1	BACKUP SPACER	
23.	318-873	-	BRACKET, TOP	
24.	110-852	1	BOLT-ON CLAMP(1.25",SOLD PER SET)	
25.	105-832	4	FLG LOCKNUT (1/4-NC)	
26.	107-196	2	BOLT (1/4-NC X 3")	
27.	154-102	1	CONNECTOR (12N-12J)	
28.	110-411	1	BOLT-ON CLAMP (3/4", SET)	
29.	322-289	1	BACKUP (BOLT-ON)	
30.	105-106	2	BOLT (1/4-NC X 2")	
31.	153-238	1	BK CONNECTOR (040-06S)	
32.	153-264	1	REDUCER (04N-06SF)	
33.	106-381	1	FLG LK SCREW(M8-1.25 X 25mm)	
34.	106-386	1	FLG LOCKNUT (M8-1.25)	

NOT SHOWN:

FOOTNOTES:

NOTE:

DRILLING FLUID TRANSFER

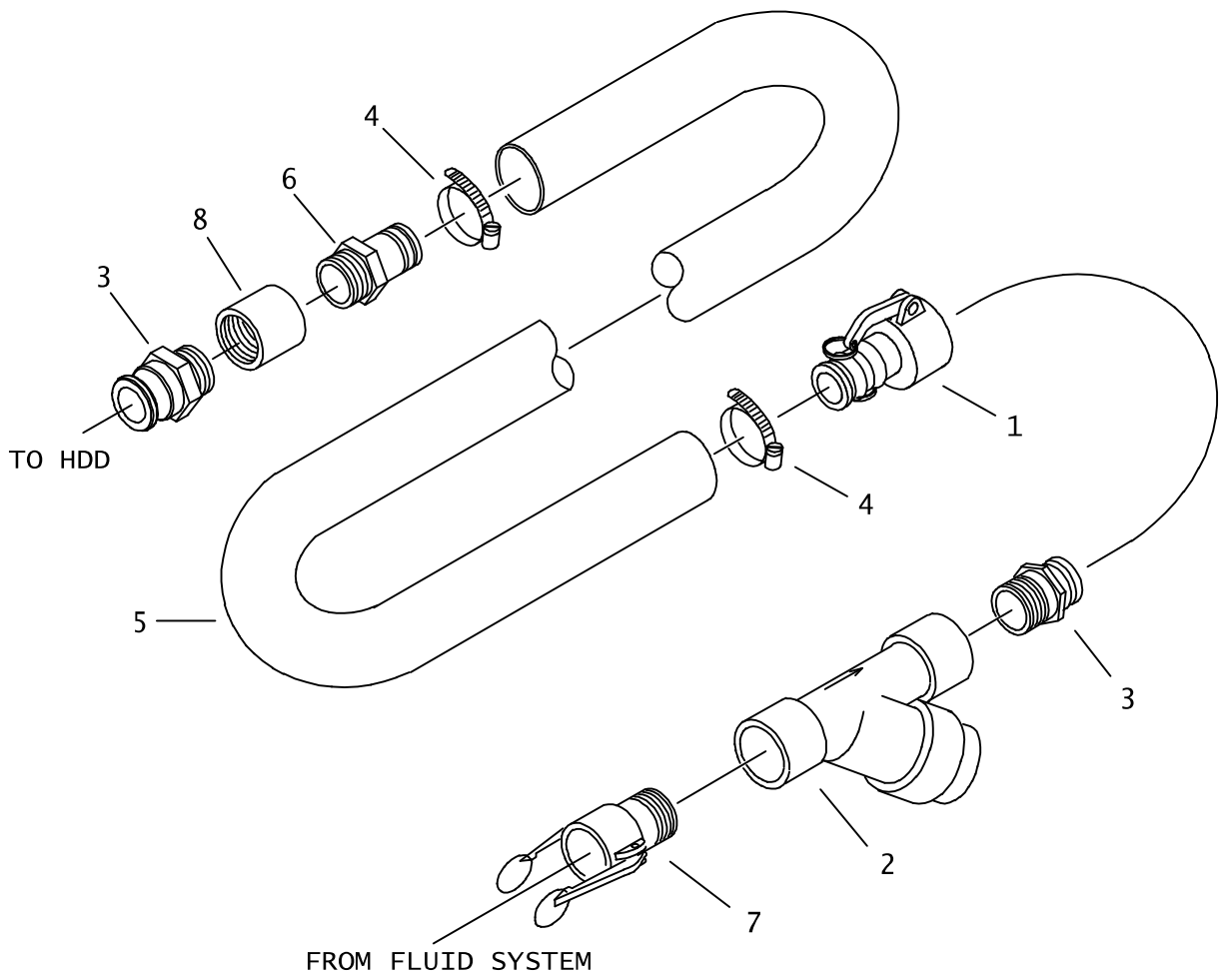

DRILLING FLUID TRANSFER

REF NO.	PART NUMBER	QTY	DESCRIPTION	REMARKS
	159-587		TRANSFER HOSE ASSEMBLY	
1.	155-205	1	FHC BODY (20-24N)	INCL REF NO'S 1, 3 (1), 4, 5, 6 & 8
2.	159-476	1	Y-STRAINER (24NF)	
	159-503		SCREEN, Y-STRAINER (12 MESH)	
	500-2080		O-RING	USED ON Y STRAINER CAP
3.	155-204	2	FHC ADAPTER (24-24N)	
4.	110-250	2	WORM CLAMP (1," TO 2,")	
5.	116-782	AR	BULK HOSE (1.50", SOLD PER 1")	USE 1 @ 300"
6.	155-188	1	S/O COUPLER (24N-24H)	
7.	159-500	1	FHC BODY (24-24N)	
8.	115-134	1	COLLAR (24NF)	

NOT SHOWN:

FOOTNOTES:

NOTE:

NOTES:

PIPE LOADER SYSTEMS

PIVOT ARM

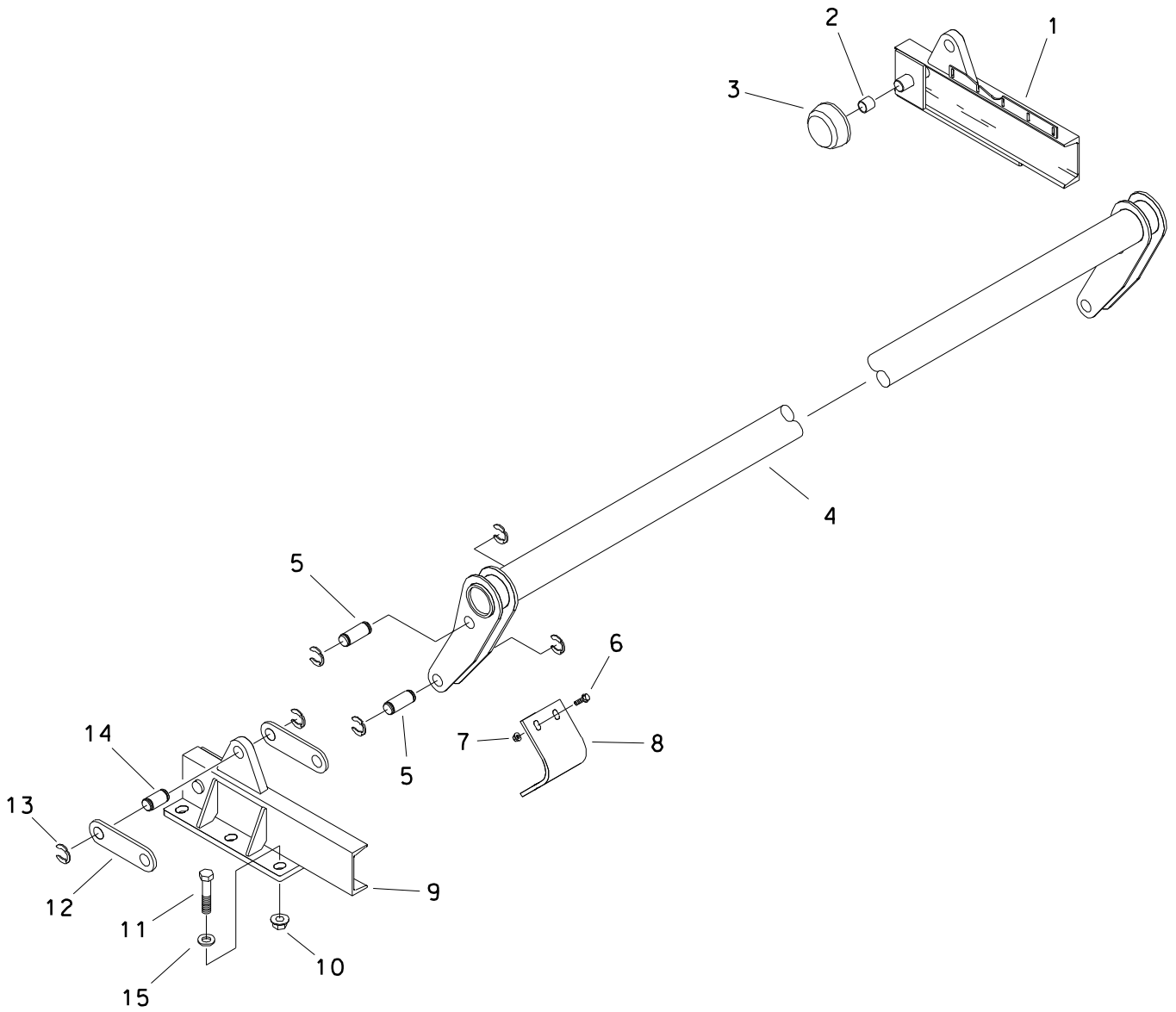

PIVOT ARM

REF NO.	PART NUMBER	QTY	DESCRIPTION	REMARKS
1.	316-528	1	FRONT ROLLER GUIDE	
2.	125-770	2	COMPOSITION BUSHING (1")	
3.	184-084	2	CARRIAGE ROLLER	
4.	318-785	1	PIVOT ARM	
5.	179-451	4	TRAVERSE PIN	
6.	106-383	8	FLG LK SCREW (M10-1.50 X 30MM)	
7.	106-387	8	FLG LOCKNUT (M10-1.50)	
8.	318-678	2	PIVOT ARM BRACKET	
9.	316-529	1	REAR ROLLER GUIDE	
10.	106-355	6	FLG NUT (M16-2.00, 10.9)	
11.	106-616	6	SCREW (M16-2.00 X 55MM)	
12.	319-191	4	LINK	
13.	115-499	12	KLIP RING (1.000")	
14.	179-483	2	PIN	
15.	106-398	6	WASHER (M16, HARDENED)	

FOOTNOTES

LIFTERS

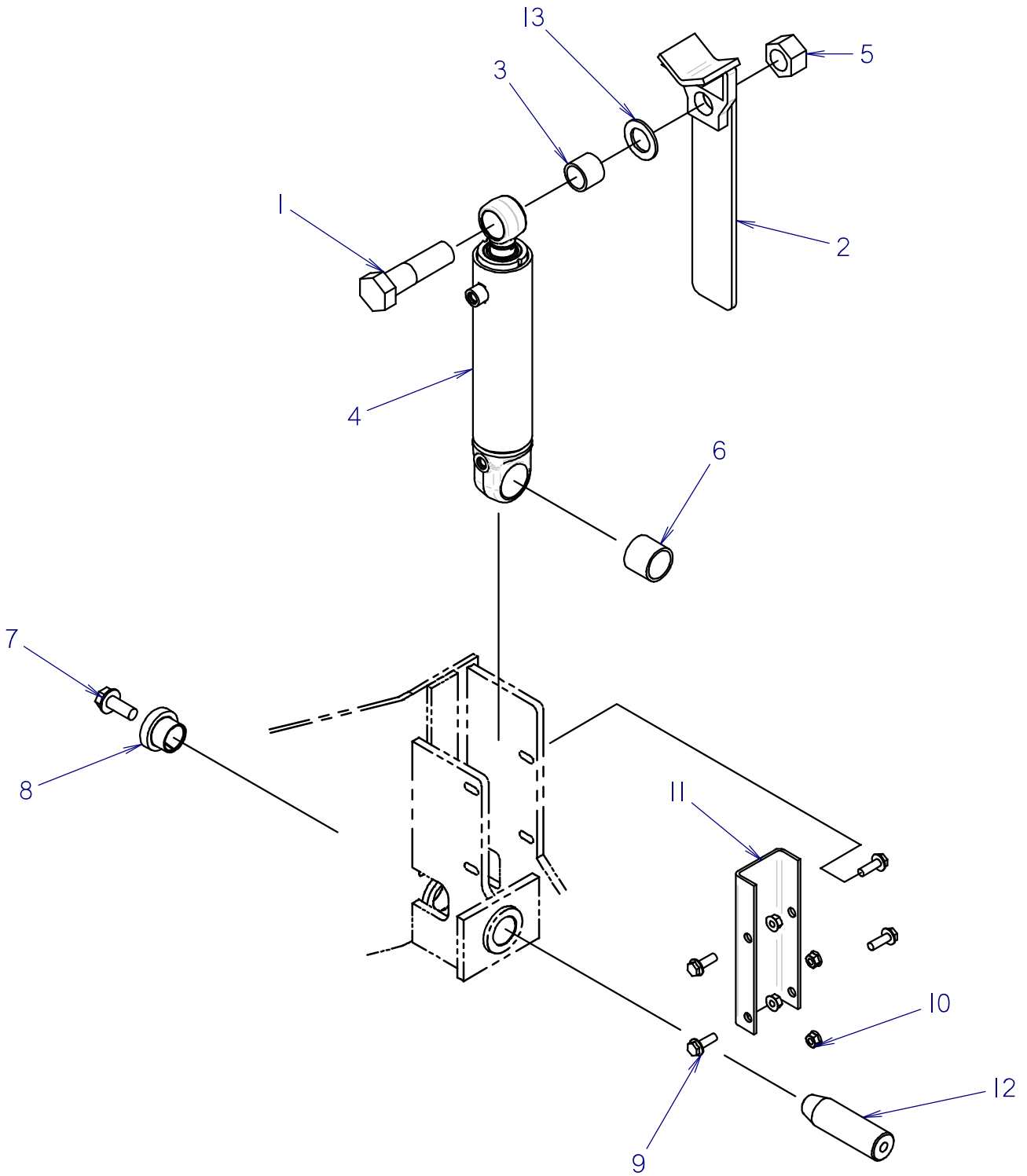

LIFTERS

REF NO.	PART NUMBER	QTY	DESCRIPTION	REMARKS
1	106-664	1	SCREW (M24-3.00 X 90MM, I0.9)	
2	300-1061	1	LIFTER PLATE	USE ON JT2020 FOOTNOTE 1 (SEE FOOTNOTE 2 FOR JT1220)
3	125-770	1	COMPOSITION BUSHING (1.000")	
4	151-044	1	CYL (2.0 X 1.0 X 6.0)	
5	106-352	1	NUT (M24-3.00)	
6	125-771	1	COMPOSITION BUSHING (1.25")	
7	105-830	1	FLG LK BOLT (1/2-NC X 1-1/4")	
8	181-982	1	TAPERED INSERT (1.25")	
9	106-381	4	FLG LK SCREW (M8-1.25 X 25MM)	
10	106-386	4	FLG LOCKNUT (M8-1.25)	
11	324-482	1	CHANNEL	
12	178-394	1	TAPERED PIN (1.250" X 4.25")	
13	106-016	1	SPINDLE WASHER (1.062")	

NOT SHOWN:

FOOTNOTES:

1. 300-1061 | LIFTER PLATE, BEGINS WITH S/N: CMWJ2020H60000346 ; USE ON JT2220
2. 316-569 | LIFTER PLATE, BEGINS WITH S/N: CMWJ1220J60000130 ; USE ON JT1220

NOTE:

LIFTERS

ENDS WITH S/N: CMWJ1220J60000129

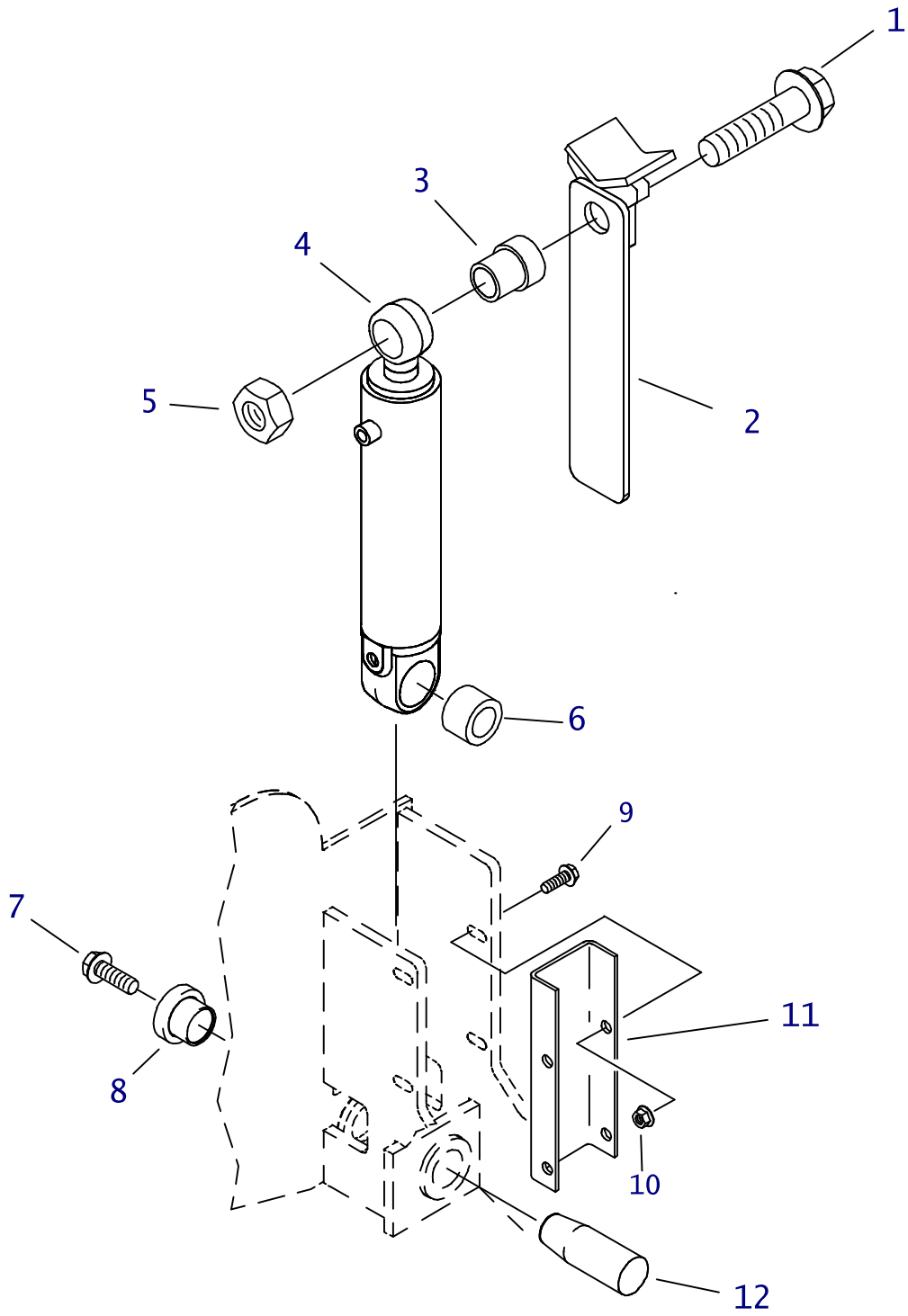

LIFTERS

ENDS WITH S/N: CMWJ1220J60000129

REF NO.	PART NUMBER	QTY	DESCRIPTION	REMARKS
1.	106-664	2	FLG SCREW (M24-3.00 X 90MM,10.9)	
2.	316-569	2	LIFTER GUIDE PLATE	
3.	179-520	2	BUSHING	
4.	151-044	2	CYL (2.0 X 1.0 X 6.0)	
5.	106-352	2	NUT (M24-3.00)	
6.	125-771	2	COMPOSITION BUSHING (1.25")	
7.	105-830	2	FLG LK BOLT (1/2-NC X 1-1/4")	
8.	181-982	2	TAPERED INSERT (1.25")	
9.	106-381	4	FLG LK SCREW (M8-1.25 X 25MM)	
10.	106-386	4	FLG LOCKNUT (M8-1.25)	
11.	324-482	2	CHANNEL	
12.	178-394	2	TAPERED PIN (1.250" X 4.250")	

NOT SHOWN:

FOOTNOTES:

NOTE:

SHUTTLE

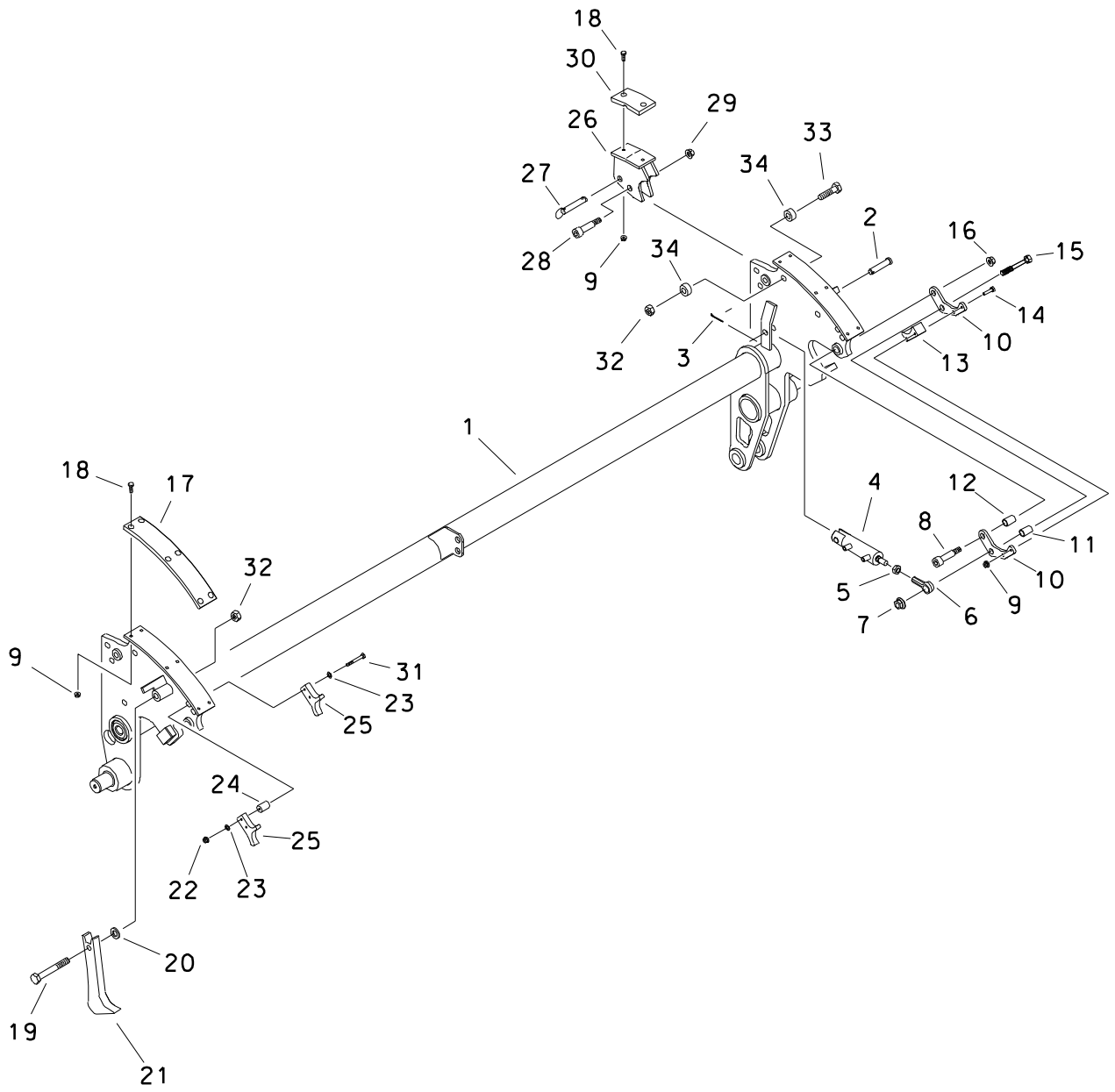

SHUTTLE

REF NO.	PART NUMBER	QTY	DESCRIPTION	REMARKS
1.	316-508	1	SHUTTLE	
2.	108-057	2	CLEVIS PIN (1/2" X 2-1/4")	
3.	105-509	2	COTTER PIN (1/8" X 1")	
4.	151-150	2	CYL (1.5" X .50" X 2")	
5.	105-920	2	JAM NUT (7/16-NF)	
6.	110-983	2	ROD END (7/16" NF-20, FM)	
7.	106-758	2	LOCKNUT (M10-1.5)	
8.	106-132	2	SHLD BLT (1/2" X1-1/2", 3/8-NC)	
9.	106-385	20	FLG LOCKNUT (M6-1.00)	
10.	316-502	4	PLATE	
11.	179-387	2	GRIPPER SPACER	
12.	125-430	2	BRONZE BUSHING (.502")	
13.	315-740	2	SHUTTLE GRIPPER PAD	
14.	106-093	4	SCREW (M6-1.00 X 45MM)	
15.	106-142	2	SCREW (M10-1.50 X 65MM)	
16.	105-047	2	LOCKNUT (3/8-NC)	
17.	323-206	2	SHUTTLE WEAR PAD	
18.	106-640	16	SCREW (M6-1.00 X 20MM, BUT SOC)	
19.	106-584	2	SCREW (M12-1.75 X 100MM)	
20.	106-391	2	WASHER (M12)	
21.	316-495	2	CATCH ARM	
22.	106-237	4	LOCKNUT (M6-1.00, PRV TRQ, NLK)	
23.	106-388	8	WASHER (M6)	
24.	179-531	4	BUSHING	
25.	315-739	4	GRIPPER PAD	
26.	323-204	2	SWIVEL BODY	
27.	183-411	2	PULL PIN (1/2" X 2")	
28.	107-043	2	SHLD BLT (M12 X 35MM, M10-1.50)	
29.	105-894	2	LOCKNUT (M10-1.50, PRV TRQ, 10.9)	
30.	323-205	2	WEAR PAD	
31.	107-025	4	SCREW (M6-1.00 X 50MM)	
32.	106-685	4	LOCKNUT (M12-1.75, PRV TRQ, 10.9)	
33.	106-334	2	SCREW (M12-1.75 X 50MM)	
34.	179-831	4	BUSHING	

FOOTNOTES

SHUTTLE MOUNT

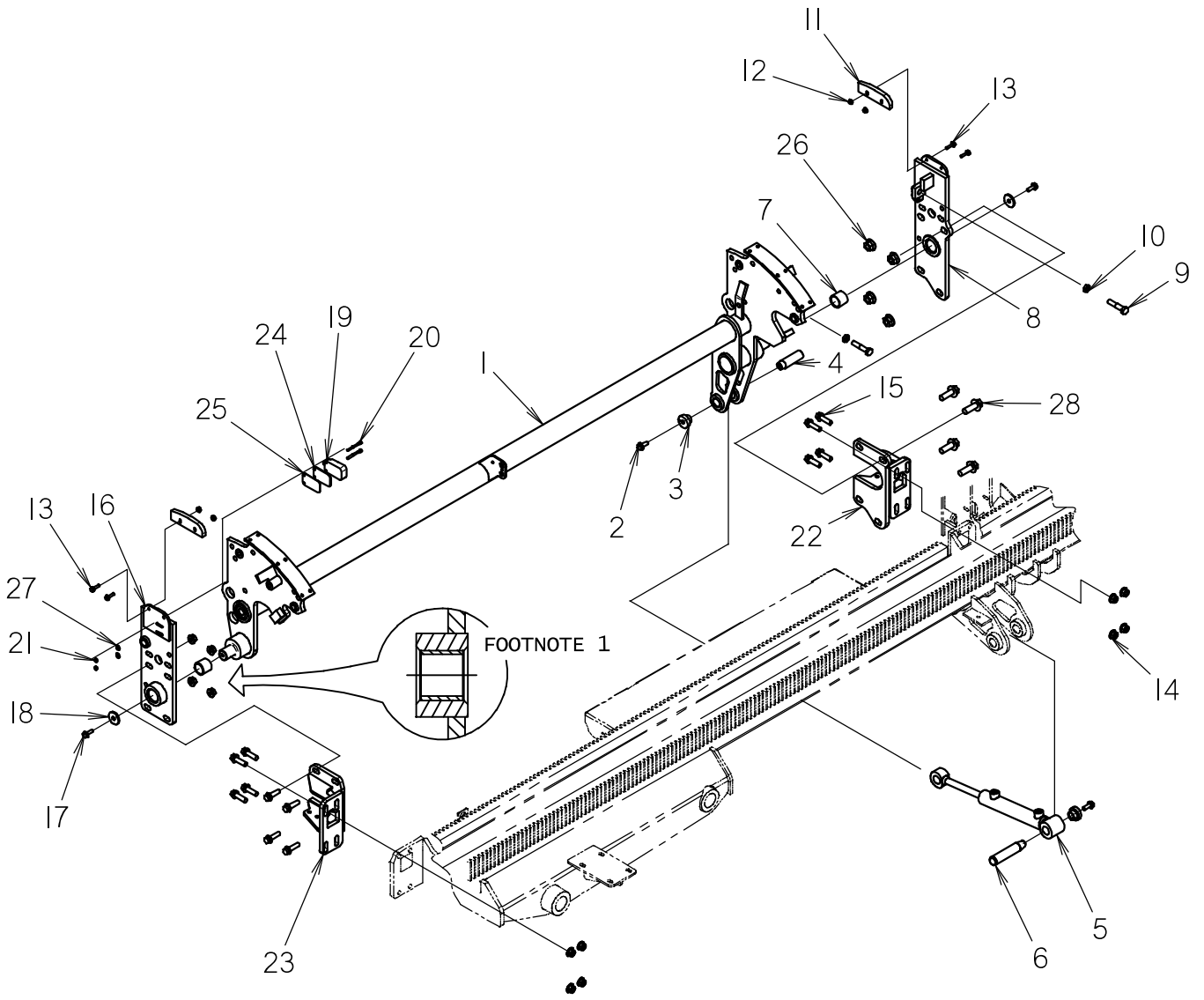

SHUTTLE MOUNT

REF NO.	PART NUMBER	QTY	DESCRIPTION	REMARKS
1	316-508	1	SHUTTLE	
2	106-724	2	FLG SCREW (M10-1.50 X 25MM)	
3	181-981	2	TAPERED INSERT (1")	
4	183-820	1	TAPERED PIN (25.4MM X 86MM)	
5	151-230	1	CYL (1.25" X .75" X 6")	
6	183-764	1	25.4 X 126 TAPERED PIN	
7	125-771	2	COMPOSITION BUSHING (1.25")	
8	316-696	1	MOUNT PLATE	
9	106-594	2	SCREW (M12-1.75 X 60MM)	
10	107-669	2	JAM NUT (M12-1.75)	
11	119-004	2	CATCH ARM WARE PAD	
12	106-385	4	FLG LOCKNUT (M6-1.00)	
13	106-848	4	FLG SCREW (M6-1.00 X 25MM)	
14	106-709	12	FLG LK NUT (M12-1.75)	
15	107-565	12	FLG LK SCREW (M12-1.75 X 40MM)	
16	319-530	1	MOUNT PLATE	
17	106-381	2	FLG LK SCREW (M8-1.25 X 25MM)	
18	105-069	2	WASHER (.406")	
19	215-1175	1	PROXIMITY SWITCH	
20	108-091	2	SCREW (M5-0.80 X 50MM, SOC)	
21	106-850	2	LOCKNUT (M5-0.80)	
22	320-234	1	FRONT MOUNT BRACKET	
23	320-235	1	REAR MOUNT BRACKET	
24	107-451	1	SHIM (.135")	SEE FOOTNOTE 2
25	107-450	1	SHIM (.075")	SEE FOOTNOTE 2
26	106-355	4	FLG NUT (M16-2.00, 10.9)	
27	105-284	2	WASHER (3/16")	
28	107-336	4	FLG SCREW (M16-2.00X45MM,10.9)	

NOT SHOWN:

116-259

BULK EDGING (1/2" SOLD PER FT)

VARIOUS QUANTITIES & LENGTHS USED

FOOTNOTES:

1. ASSEMBLY BUSHING (REF 7) IN CENTER OF BOSS AS SHOWN
2. USE AS REQUIRED

NOTE:

SHUTTLE GUARD

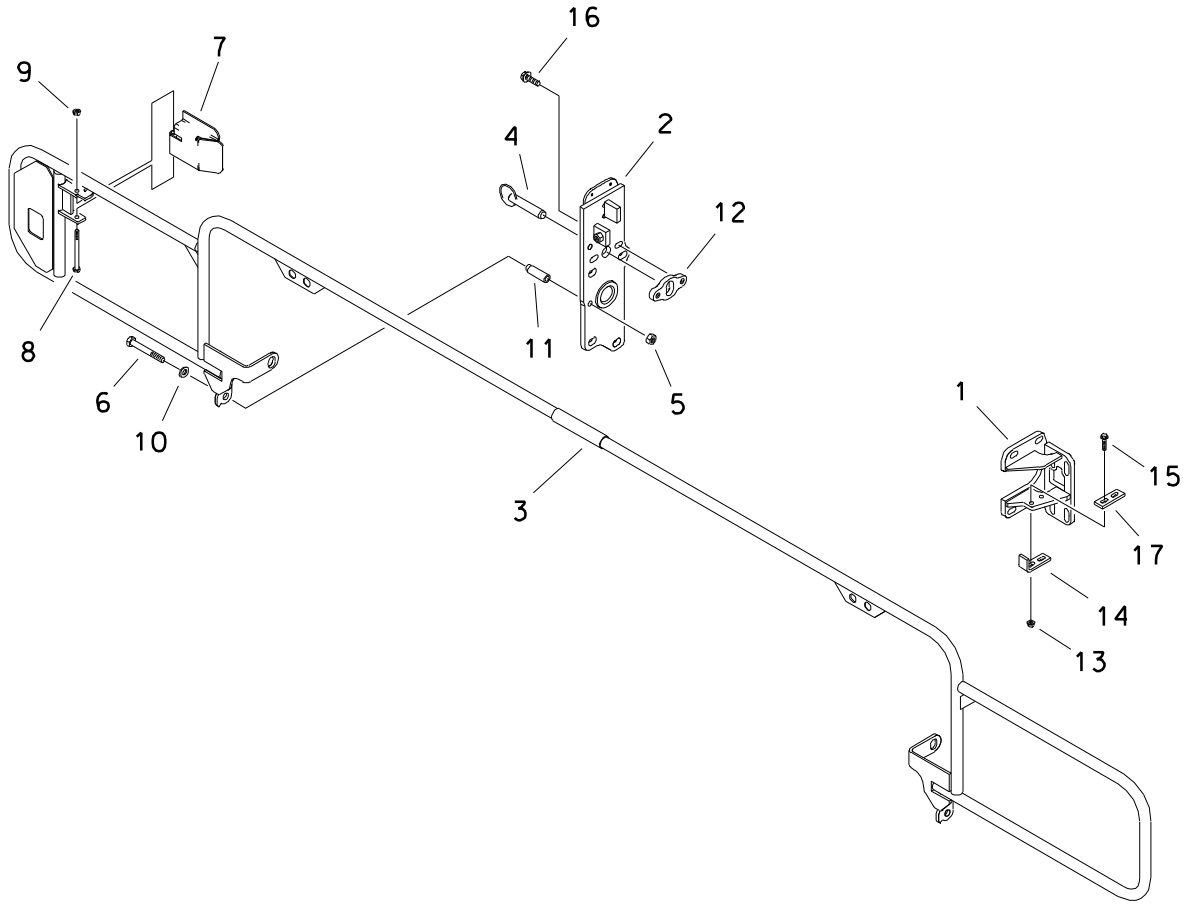

SHUTTLE GUARD

REF NO.	PART NUMBER	QTY	DESCRIPTION	REMARKS
1.	320-235	-	REAR MOUNT BRACKET	
2.	316-696	-	MOUNT PLATE	
3.	319-823	1	SHUTTLE GUARD	
4.	107-877	2	PIN	
5.	106-089	2	NUT (M12-1.75, 10.9)	
6.	106-336	2	SCREW (M12-1.75 X 90MM)	
7.	319-832	1	PIPE STOP	
8.	107-078	1	SCREW (M8-1.25 X 90MM)	
9.	106-561	1	LOCKNUT (M8-1.25, PRV TRQ, 10.9)	
10.	106-391	2	WASHER (M12)	
11.	179-756	2	PIVOT TUBE	
12.	322-648	2	PIN PLATE	
13.	106-386	4	FLG LOCKNUT (M8-1.25)	
14.	322-498	2	STOP BRACKET	
15.	106-989	4	FLG LK SCREW (M8-1.25 X 35MM)	
16.	107-010	4	FLG LK SCREW (M12-1.75 X 30MM)	
17.	325-514	2	STOP BAR	

FOOTNOTES

PIPE LOADER VALVE/COVERS

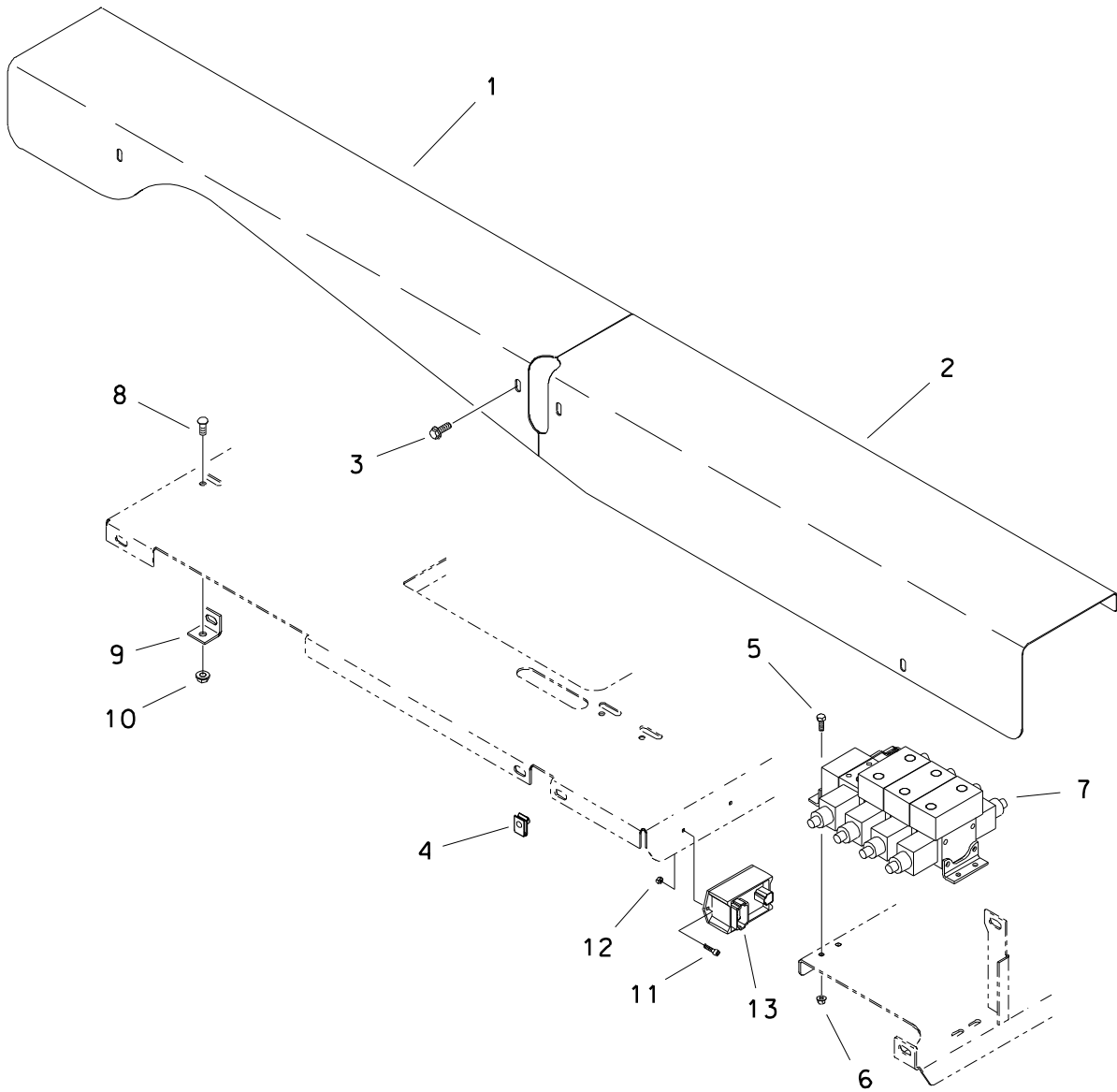

PIPE LOADER VALVE/COVERS

REF NO.	PART NUMBER	QTY	DESCRIPTION	REMARKS
1.	319-506	1	FRONT COVER	
2.	319-507	1	REAR COVER	
3.	106-380	8	FLG SCREW(M8-1.25 X 16MM)	
4.	106-551	8	CLIP NUT (M8-1.25)	
5.	106-231	4	SCREW (M6-1.00 X 16MM)	
6.	106-385	4	FLG LOCKNUT (M6-1.00)	
7.	157-778	1	HYDRAULIC VALVE	
8.	107-032	3	SCREW (M8-1.25 X 20MM,BUT SOC)	
9.	320-656	3	CLIP NUT TAB	
10.	106-386	3	FLG LOCKNUT (M8-1.25)	
11.	106-049	2	BOLT (#10-24 X ³ / ₄ " , PLPS)	
12.	106-048	2	LOCKNUT (#10-24)	
13.	211-025	1	IN-LINE DIODE PACK	

FOOTNOTES

PIPE BOX

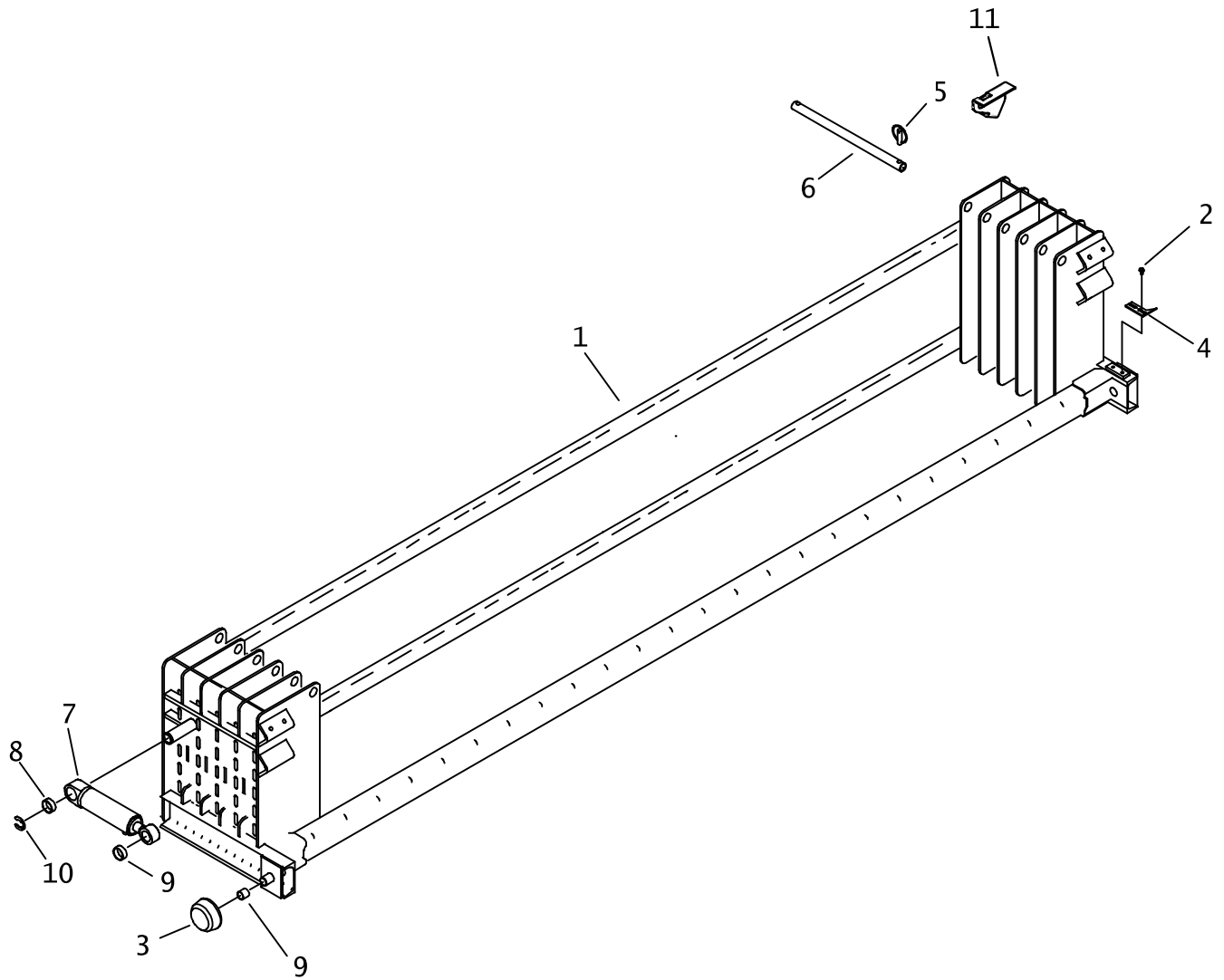

PIPE BOX

REF NO.	PART NUMBER	QTY	DESCRIPTION	REMARKS
1.	316-530	1	PIPE BOX	
2.	106-224	2	FLG SCREW (M6-1.00 X 10MM)	
3.	184-084	2	CARRIAGE ROLLER	
4.	316-979	1	INDICATOR	
5.	110-228	4	LYNCH PIN (7/16" X 2")	
6.	107-882	2	PIN	
7.	151-038	2	CYL (2.0 X 1.0 X 4.0)	
8.	125-771	2	COMPOSITION BUSHING (1.25")	
9.	125-770	4	COMPOSITION BUSHING (1")	
10.	115-483	2	KLIP RING (1.250")	
11.	327-734	4	INDICATOR	

FOOTNOTES

NOTE:

C

808-436

ELECTRICAL

**SEE TECHNICAL SUPPLEMENT FOR FURTHER
ELECTRICAL INFORMATION**

ACCESSORIES

COLD START KIT

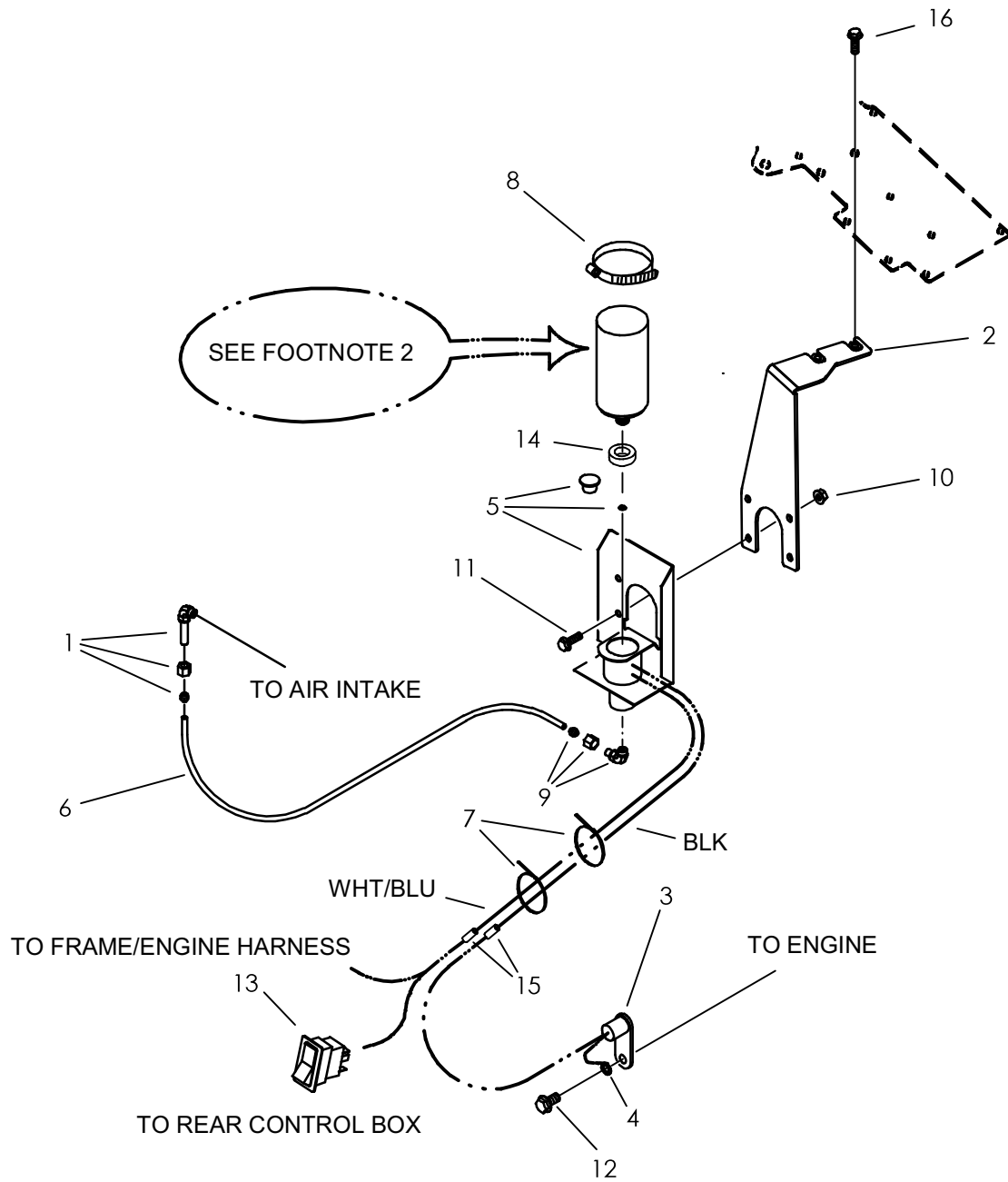

COLD START KIT

REF NO.	PART NUMBER	QTY	DESCRIPTION	REMARKS
	101-161		COLD START KIT	
1.	195-843	1	INJECTOR NOZZLE (CLDSTRT)	INCL REF NO.S 1-15 & KIT INSTRUCTIONS - ID0142683
	156-204		- FERRULE (02T)	
	156-205		- COMPRESSION NUT (02T)	
2.	324-578	1	MOUNT	
3.	215-073	1	SENSOR SWITCH	SEE FOOTNOTE 1
4.	215-590	1	RING TERMINAL (.375")	SEE FOOTNOTE 1
5.	306-628	1	VALVE/CANISTER BRACKET	
	110-252		- CAPLUG (3/4")	
	195-844		- GASKET	
6.	156-018 AR		BULK TUBING (1/8", SOLD PER 1")	USE 1@ 30"
7.	110-248	2	CABLE TIE (1/16" TO 1-1/4")	
8.	110-169	1	WORM CLAMP (2.812" TO 3.750")	
9.	156-272	1	TUBE CONNECTOR (02N-02T90, ORF)	
	156-204		- FERRULE (02T)	
	156-205		- COMPRESSION NUT (02T)	
10.	106-386	4	FLG LK NUT (M8-1.25)	
11.	106-991	4	FLG LK SCREW (M8-1.25 X 20mm)	
12.	106-654	1	FLG LK SCREW (M10-1.50 X 16mm)	
13.	217-917	1	ROCKER SWITCH (DPDT) OFF-(ON)	
14.	106-654	1	BULK GROMMET 2-1/8" SOLD PER 1"	USE 1@ 1"
15.	215-470	1	BUTT CONNECTOR (14 GA - 16 GA)	
16.	108-064	2	FLG LK SCREW (M8-1.25 X 14mm)	

NOT SHOWN:

FOOTNOTES:

- REF NO.'S 3 & 4 BOLT ONTO ENGINE WITH ALTERNATOR ELECTRICAL HARNESS.
- USE OF 8 OZ. ETHER CANISTER IS REQUIRED, DOES NOT COME WITH KIT.

NOTE:

ANTIFREEZE TANK

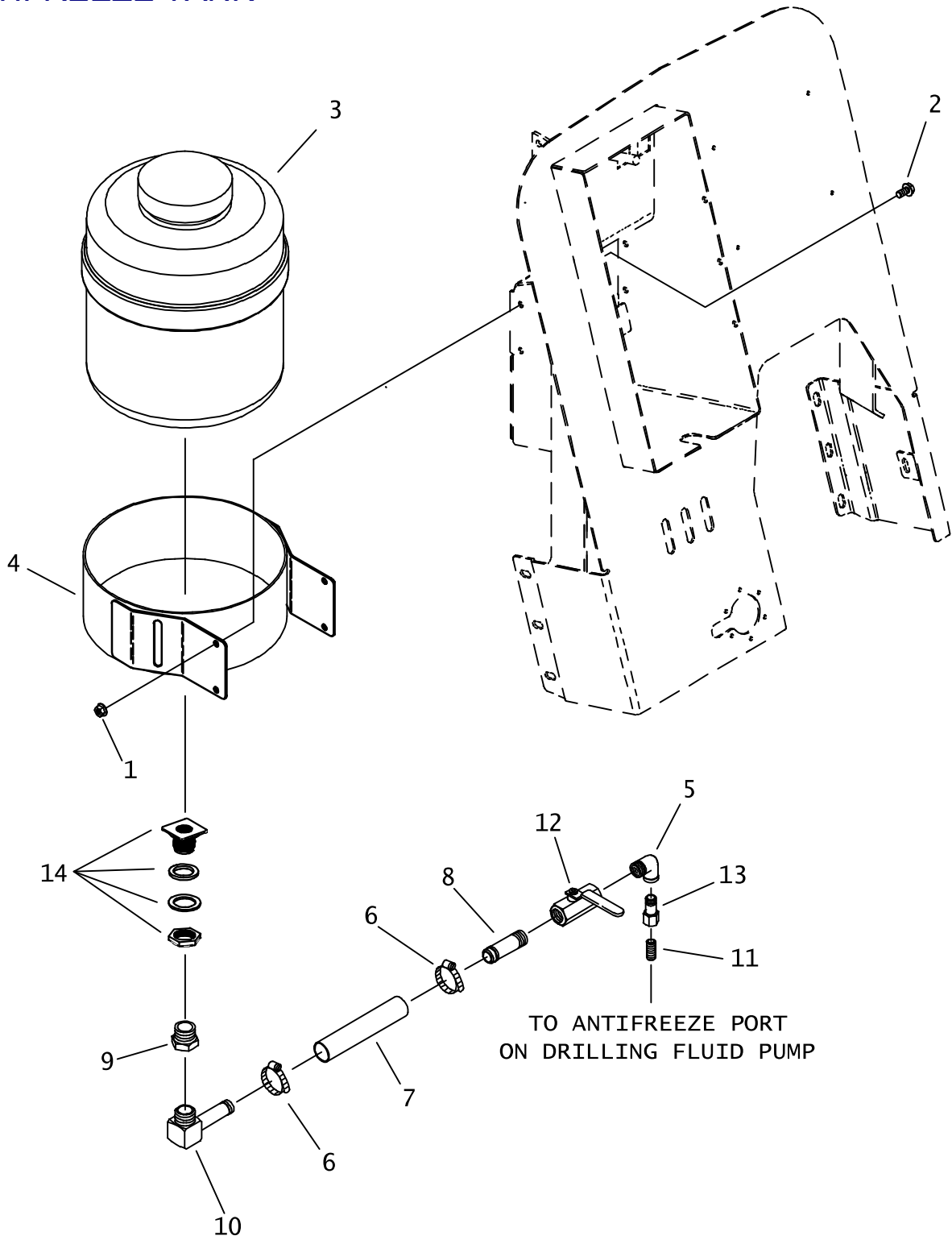

ANTIFREEZE TANK

REF NO.	PART NUMBER	QTY	DESCRIPTION	REMARKS
	101-140		ANTIFREEZE TANK OPTION	INCL REF #1 THRU #14
1.	106-386	4	FLG LOCKNUT (M8-1.25)	
2.	106-380	4	FLG LK SCREW (M8-1.25 X 16MM)	
3.	364-325	1	ANTIFREEZE TANK (3 GAL)	SEE FOOTNOTE I
	110-707		TANK CAP (96NF)	
4.	315-125	1	TANK MOUNT	
5.	115-141	1	PIPE ELBOW (3/8NPT)	
6.	110-217	2	WORM CLAMP (7/16" TO 1")	
7.	116-881	AR	BULK HOSE (3/8", SOLD PER FT)	USE 1 @ 20"
8.	514-369	1	S/O COUPLER (06N-06H)	
9.	115-219	1	REDUCER (12N-06NF)	
10.	153-871	1	S/O COUPLER (06N-06H90, BRS)	
11.	115-129	1	ALL THREAD (04N) SCH 80	
12.	153-701	1	SHUT OFF (06NF-06NF)	
13.	115-106	1	REDUCER (06N-04NF)	
14.	500-1289	1	BK CONNECTOR (12NF, POLY)	

NOT SHOWN:

FOOTNOTES:

I. INCLUDES REFERENCE NO. I4

NOTE:

UMBRELLA

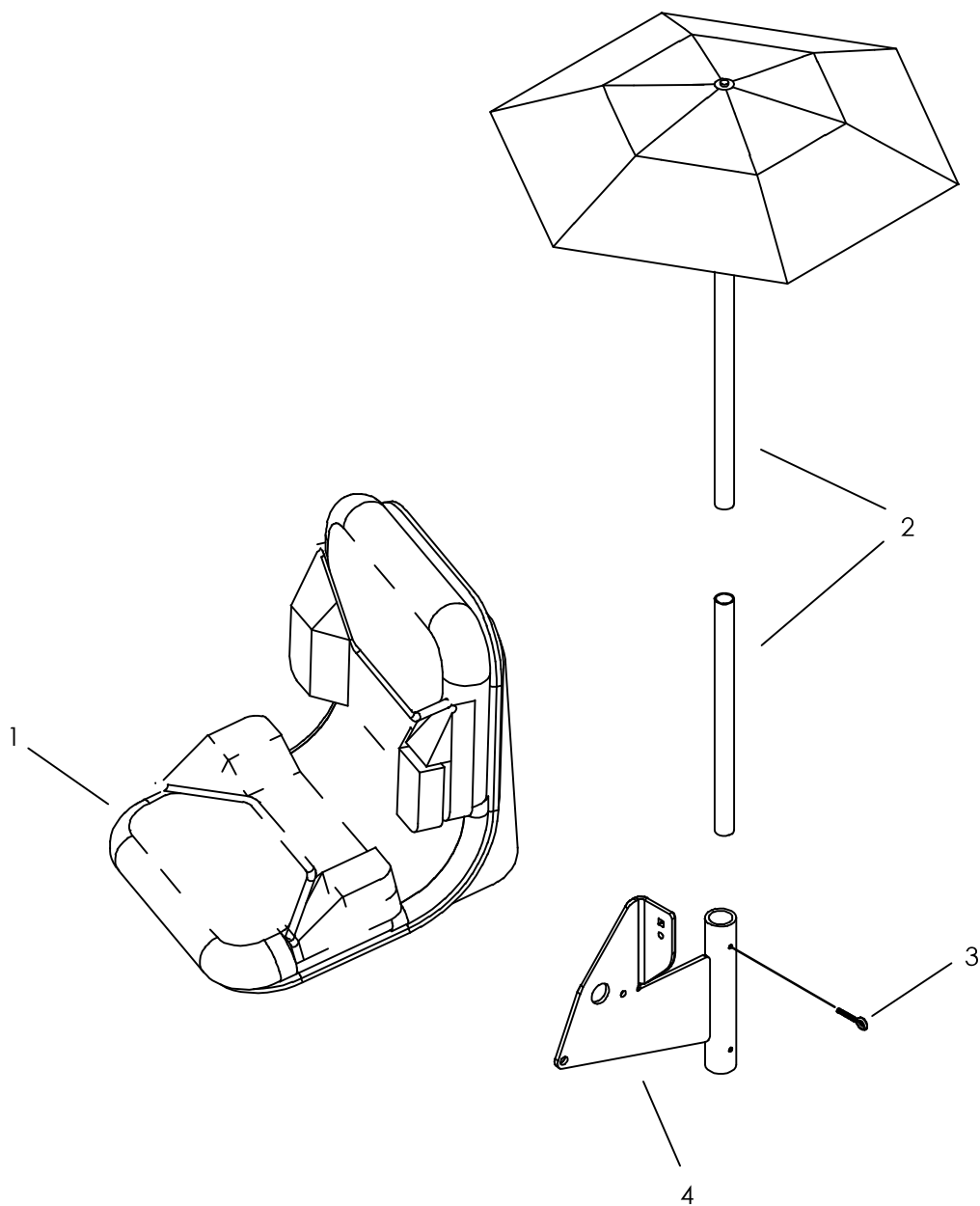

UMBRELLA

REF NO.	PART NUMBER	QTY	DESCRIPTION	REMARKS
1.	117-631	-	SEAT	
2.	344-0001	1	UMBRELLA	
	500-1962	-	UMBRELLA POLE (16")	
3.	105-204	2	EYE BOLT (1/4-NC X 1 1/2")	
4.	324-500	1	ARMREST	USE EXISTING HARWARE FOR MOUNTING (REF PARTS PAGE ID0039911)

NOT SHOWN:

FOOTNOTES:

UMBRELLA KIT (101-160) CONTAINS ITEMS 2, 3 AND 4.

NOTE:

HEATED GREASER

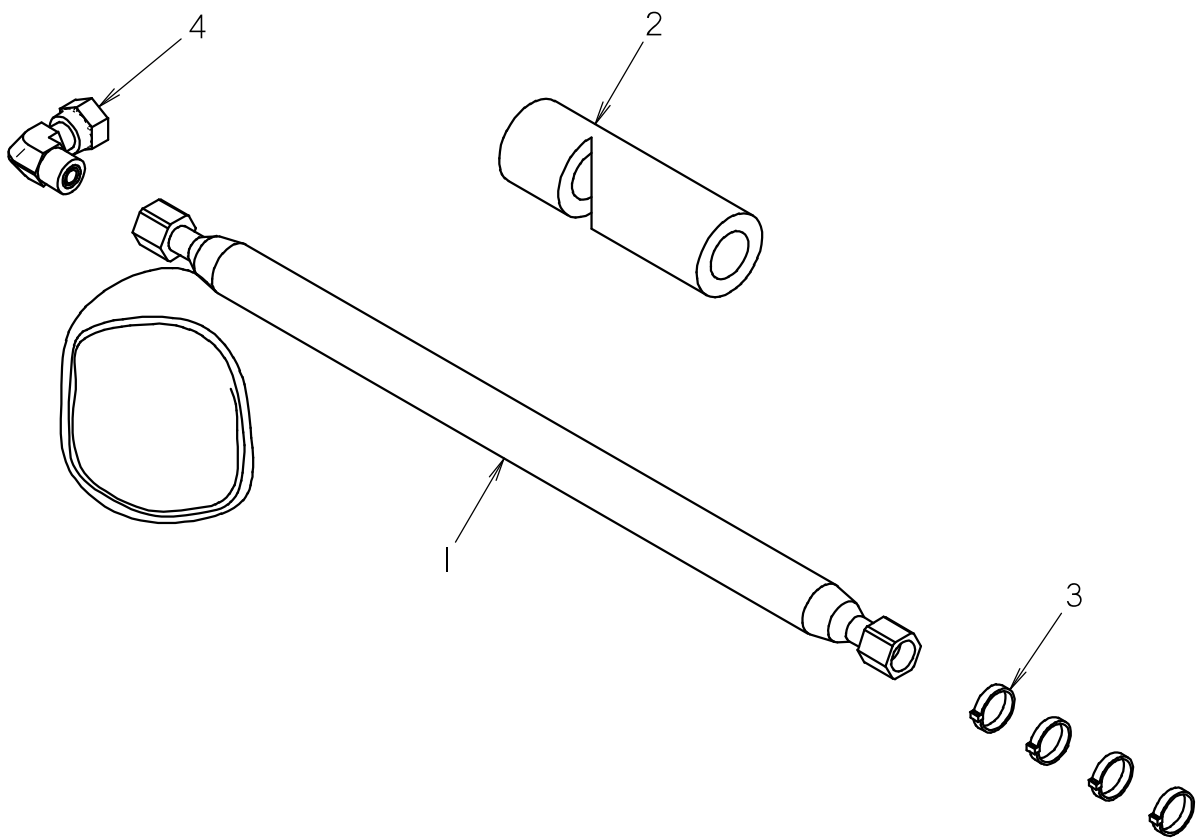

HEATED GREASER

REF NO.	PART NUMBER	QTY	DESCRIPTION	REMARKS
	101-089		HEATED HOSE KIT	INCLUDES REF NO.'S 1-4
1	153-585	1	HOSE (060FX-18"-3000, SPCL)	
2	117-549	1	INSULATOR (1" ID X 5.00")	
3	110-030	4	CABLE TIE (1/16" TO 4")	
4	154-228	1	UNION (060-060FX90)	

NOT SHOWN:

FOOTNOTES:

NOTE:

CANOPY

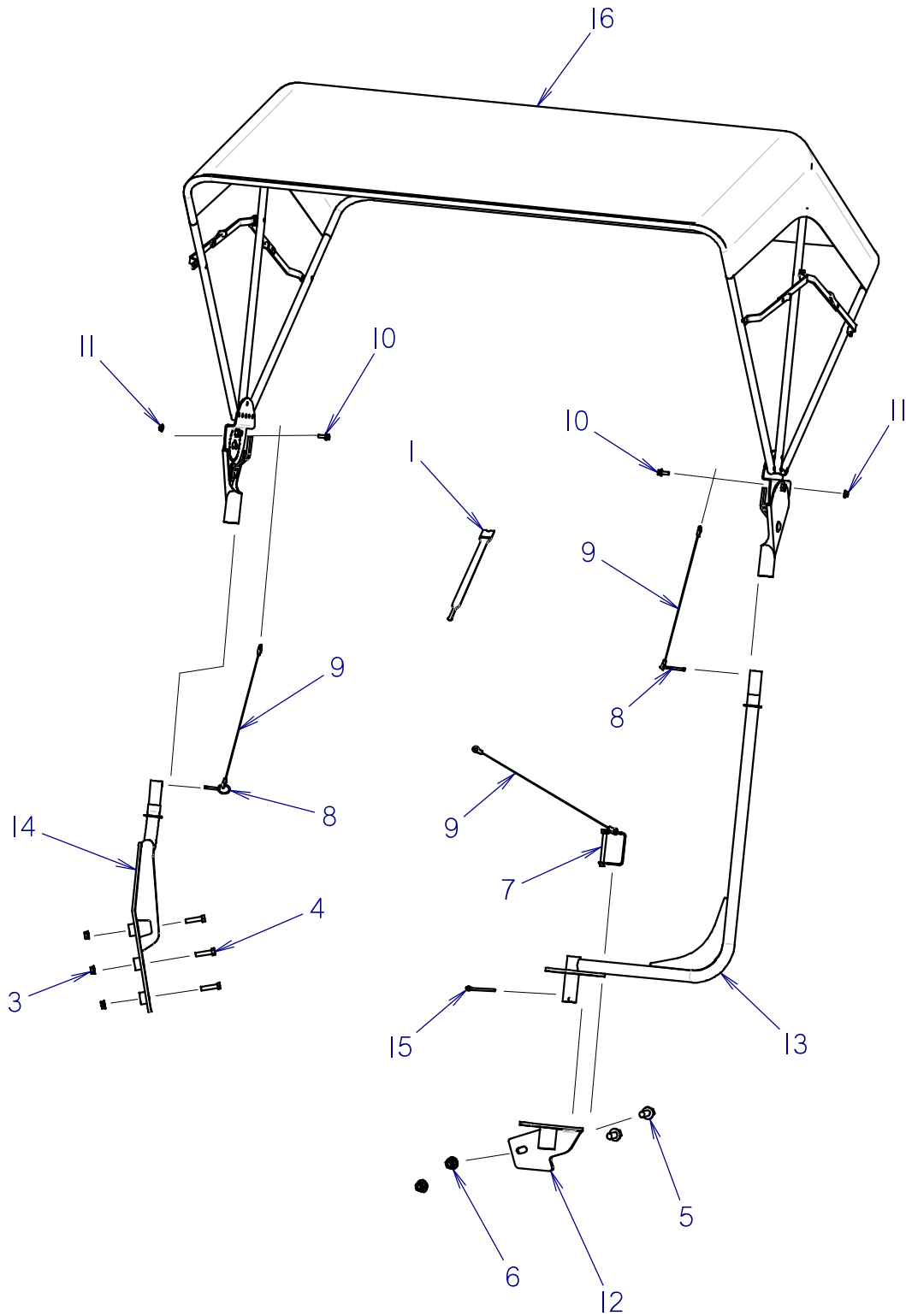

CANOPY

REF NO.	PART NUMBER	QTY	DESCRIPTION	REMARKS
	101-164		CANOPY KIT	INCLUDES REF. NO.'S 1-14 REFER TO INSTRUCTIONS 051-435
1	118-341	1	VELCRO STRAP	SUPERSEDES 118-215, FOR SERVICE PARTS SEE FOOTNOTE 1
3	106-386	3	FLG LOCKNUT (M8-1.25)	
4	106-267	3	SCREW (M8-1.25 X 35MM)	
5	106-806	2	FLG LK SCREW (M12-1.75 X 25MM)	
6	106-709	2	FLG LK NUT (M12-1.75)	
7	110-032	1	SNAPPER PIN (5/16" X 2-1/2")	
8	110-284	2	PULL PIN (3/16" X 13/16")	
9	110-239	3	LANYARD CABLE (13.5")	
10	106-712	2	FLG SCREW (M6-1.00 X 16MM)	
11	106-385	2	FLG LOCKNUT (M6-1.00)	
12	324-546	1	MOUNT WELDMENT	
13	324-508	1	OUTER MOUNT	
14	324-515	1	CONSOLE MOUNT WELDMENT	
15	105-502	1	COTTER PIN (3/16" X 2")	
16	190-1286	1	CANOPY	

NOT SHOWN:

FOOTNOTES:

1. 500-1531 FRAME; 500-1530 CANVAS COVER

NOTE:

SOFTCAB

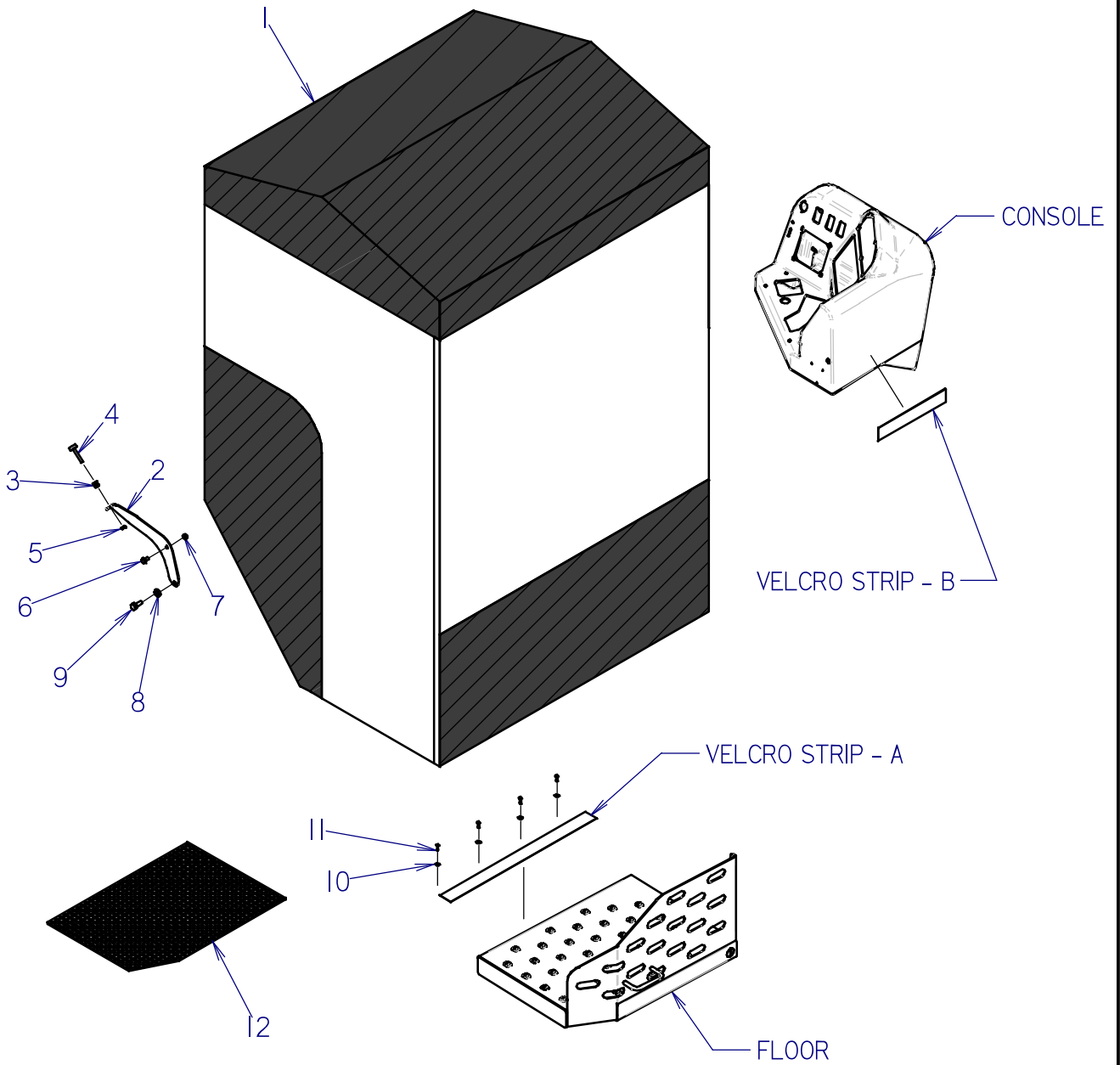

SOFTCAB

REF NO.	PART NUMBER	QTY	DESCRIPTION	REMARKS
	101-168		SOFT CAB KIT	INCLUDES REF. NO.'S 1-12. REFER TO INSTRUCTIONS 051-435
1	118-282	1	SOFTCAB	
2	327-358	1	SUPPORT PLATE	
3	106-038	1	NUTSERT 5/16	
4	118-337	1	BUMPER (2")	
5	106-252	1	JAM NUT (5/16-NC)	
6	106-380	1	FLG LK SCREW (M8-1.25 X 16MM)	
7	106-386	1	FLG LOCKNUT (M8-1.25)	
8	106-397	1	WASHER (M12, HARDENED)	
9	105-273	1	SCREW (M12-1.75 X 30MM)	
10	105-284	4	WASHER (3/16")	
11	110-449	4	POP RIVET (3/16" X .690")	
12	118-425	1	FLOOR MAT	

FOOTNOTES

NOTE:

A

809-863

T18B TIE DOWN KIT

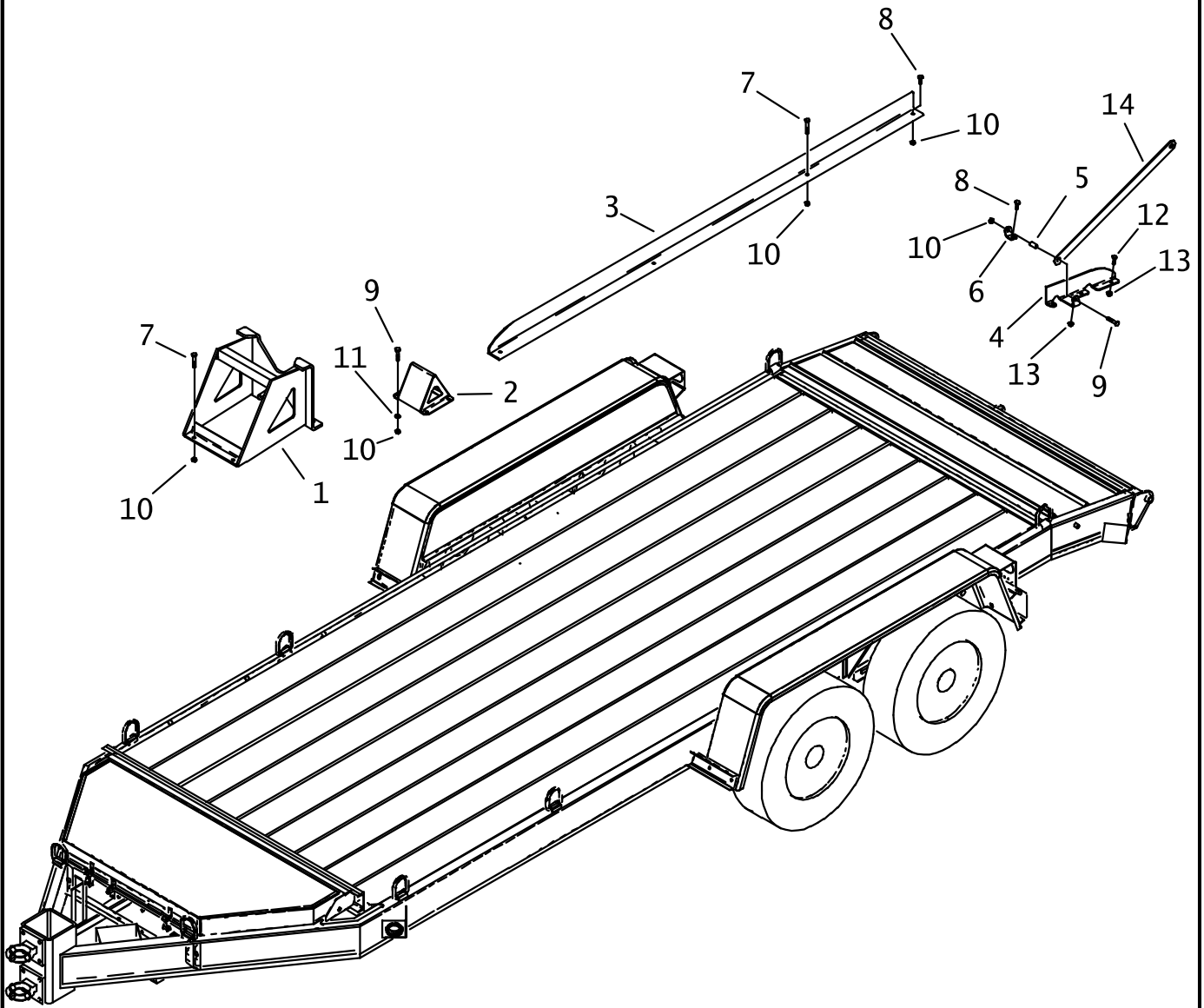

T18B TIE DOWN KIT

REF NO.	PART NUMBER	QTY	DESCRIPTION	REMARKS
	104-065	-	T18B TIE DOWN KIT	SEE FOOTNOTE 1
1.	323-705	1	FRONT MOUNT	
2.	323-951	2	STOP	
3.	323-737	1	GUIDE RAIL	
4.	323-738	1	GUIDE PLATE	
5.	178-351	1	BUSHING	
6.	323-739	1	BRACKET	
7.	107-308	7	SCREW (M12-1.75 X 75MM)	
8.	106-333	2	SCREW (M12-1.75 X 40MM, 8.8)	
9.	107-507	9	SCREW (M12-1.75 X 65MM)	
10.	106-685	17	LOCKNUT(M12-1.75,PRV TRQ,10.9)	
11.	106-391	8	WASHER (M12)	
12.	105-273	3	SCREW (M12-1.75 X 30MM)	
13.	106-709	4	FLG LK NUT (M12-1.75)	
14.	308-917	-	STOW BAR ASSEMBLY	

NOT SHOWN:

324-465	1	RIGHT TIE DOWN ASSEMBLY
324-466	1	LEFT TIE DOWN ASSEMBLY

FOOTNOTES:

1. INCLUDES REF. NO'S 1 THRU 13, 051-384 INSTRUCTIONS, AND TIE DOWN ASSEMBLIES (NOT SHOWN)

NOTE:

FM5 ON T18B

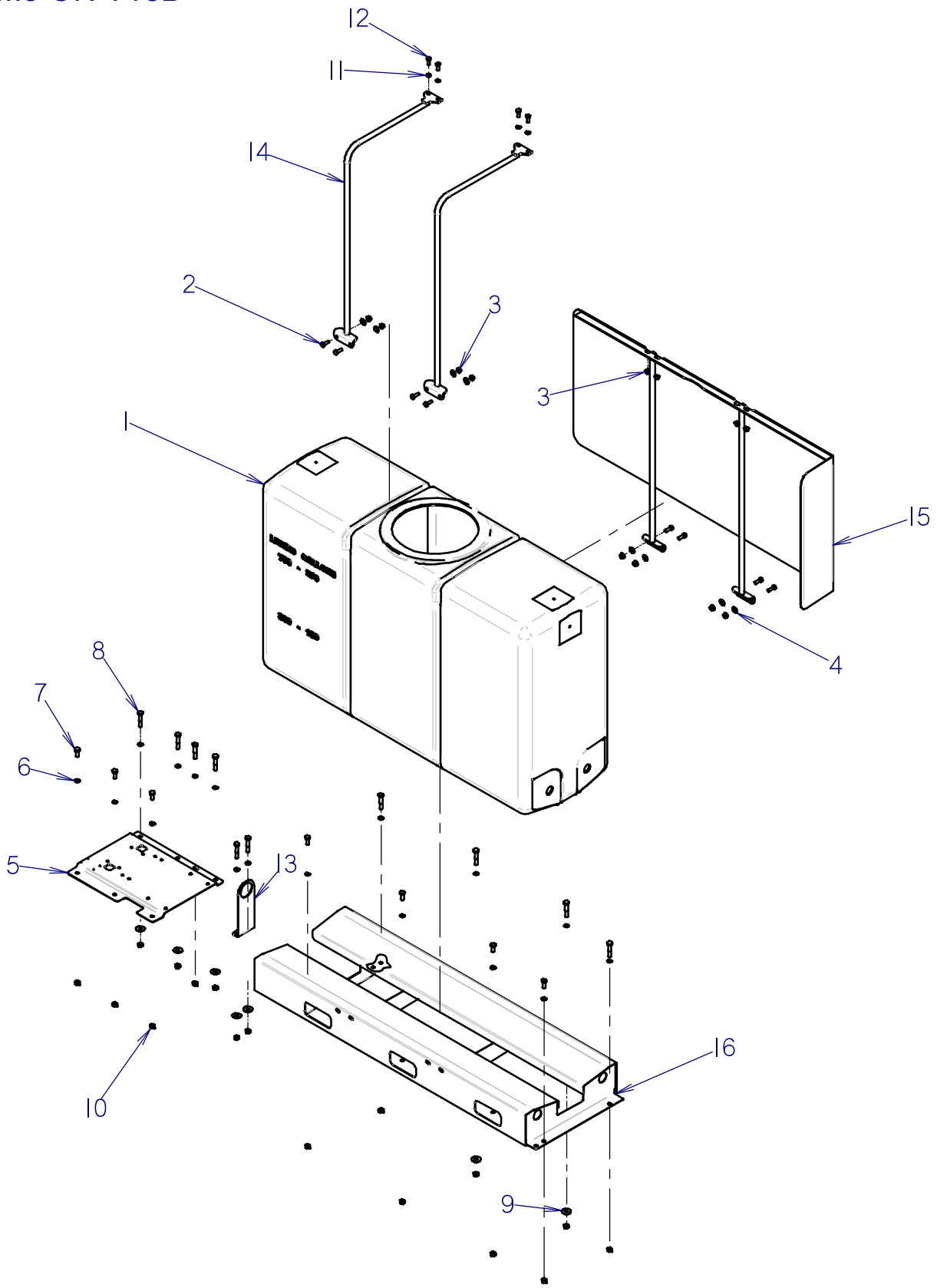

FM5 ON T18B

REF NO.	PART NUMBER	QTY	DESCRIPTION	REMARKS
	101-159		FM5 ON T18B KIT	SEE FOOTNOTE I
I	364-644	1	TANK (POLYETHYLENE, 300 GAL)	REFERENCE ONLY
2	105-247	8	SCREW (M12-1.75 X 35MM)	REFERENCE ONLY
3	106-709	12	FLG LK NUT (M12-1.75)	4 IN KIT, 8 REFERENCE ONLY
4	105-059	8	WASHER (7/16")	REFERENCE ONLY
5	322-914	1	ENGINE SUPPORT	REFERENCE ONLY
6	106-392	17	WASHER (M16)	
7	108-015	7	HHCS M14-2.0 X 35MM, 10.9, ZP	USED ON LEFT HAND SIDE
8	108-143	10	HHCS M14-2.0 X 75MM, 10.9, ZP	USED ON RIGHT HAND SIDE
9	105-359	7	WASHER (5/8)	USED WHEN NUT (REF #10) IS AGAINST WOOD
10	107-319	17	LOCKNUT (M14-2.0,PRV TRQ.10.9)	
11	106-391	4	WASHER (M12)	
12	105-273	4	SCREW (M12-1.75 X 30MM)	
13	323-681	1	VALVE SUPPORT	REFERENCE ONLY
14	323-708	2	TANK STRAP L	
15	323-489	1	TANK SHIELD	
16	324-985	1	TANK BASE	REFERENCE ONLY

FOOTNOTES

- I. INCLUDES 051-396 INSTRUCTIONS AND REF. NO.'S I-16 EXCEPT REFERENCE ONLY PARTS

NOTE:

B

809-617

PIPE BOX LOADER

REF NO.	PART NUMBER	QTY	DESCRIPTION	REMARKS
	101-167	-	PIPE BOX LOADER	INCLUDES REF NO.'S 1 THRU 15
1	115-503	4	KLIP RING (.750")	
2	325-857	2	CHANNEL	
3	118-380	8	CLAMP BAR	
4	177-090	2	STOW BAR	
5	325-856	4	RUBBER STRIP	SEE FOOTNOTE 1
6	106-386	42	FLG LOCKNUT (M8-1.25)	
7	108-182	2	MAGNET (25 MM)	
8	105-806	40	SCREW (M8-1.25 X 25MM)	
9	106-850	2	LOCKNUT (M5-0.80)	
10	108-183	2	SCREW (M5-0.8 X 16MM,CSK PLPS)	
11	106-612	4	SCREW (M16-2.00 X 180MM, 10.9)	
12	363-317	4	PROP BAR MOUNT TAB	USE WITH JT1220 ONLY
13	106-329	2	SCREW (M8-1.25 X 50MM)	USE WITH JT1220 ONLY
14	325-907	1	LIFT TUBE	
15	325-867	2	INSIDE CHANNEL	

NOT SHOWN:

FOOTNOTES:

1. APPLY 256-665 ADHESIVE TO FRONT FACE OF CHANNELS (REF. 2 & 15) BEFORE ASSEMBLING RUBBER STRIP (REF. 5)

NOTE:

TRANSPORT PIPE BOX

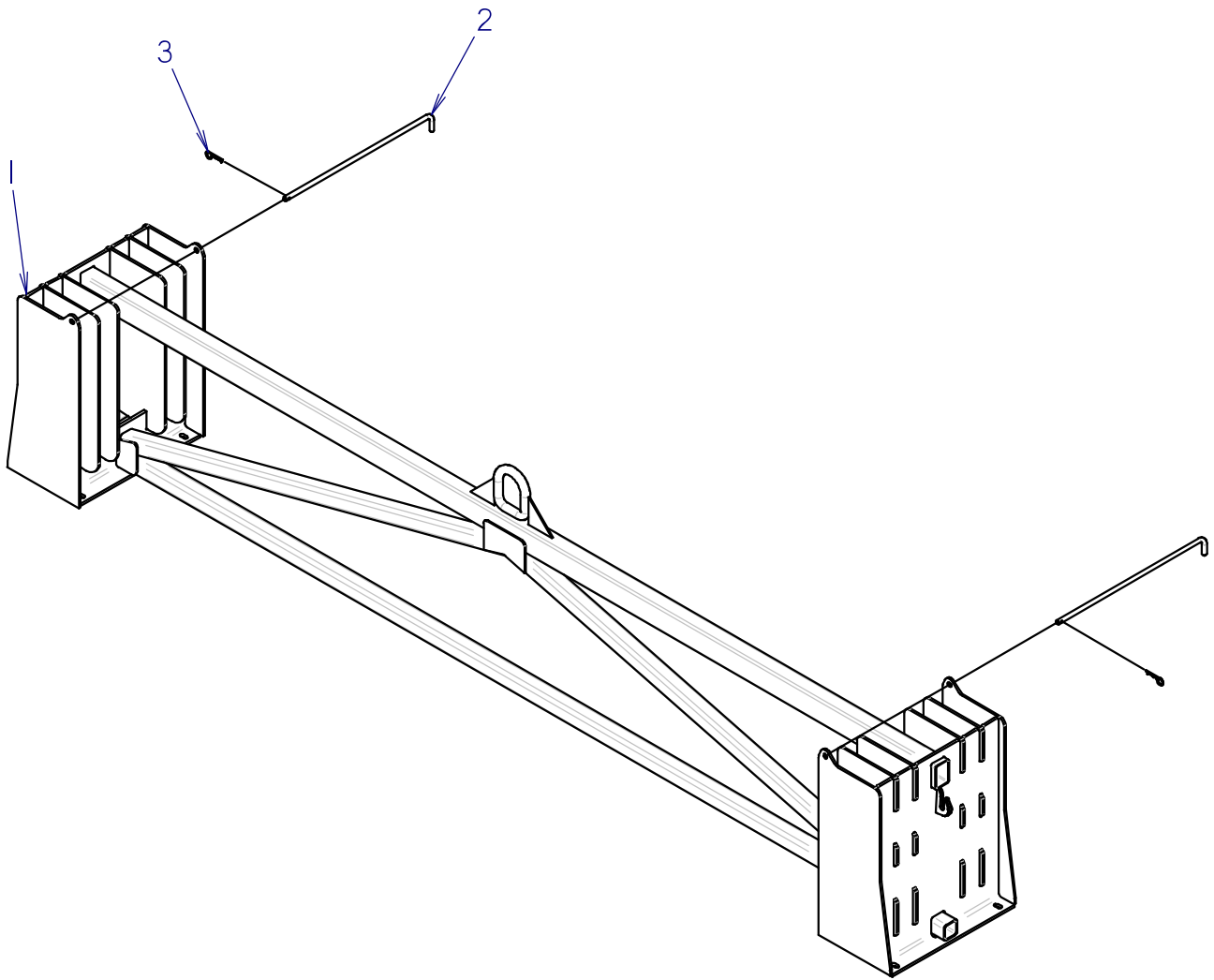

TRANSPORT PIPE BOX

REF NO.	PART NUMBER	QTY	DESCRIPTION	REMARKS
	329-873	-	AUXILIARY PIPE BOX	INCLUDES REF NO.S 1 THRU 3
1	329-857	1	TRANSPORT PIPE BOX	
2	177-028	2	TOP PIN	
3	110-033	2	HAIR CLIP PIN (1/8" X 1/2")	

NOT SHOWN:

FOOTNOTES:

NOTE:

NOTES:

MISCELLANEOUS

SAE Bolt and Nut Torque Value Chart

Grade 5: UNC or UNF Thread

Size	Hex nut, or bolt tapped into hex nut, or d&t hole		Hex top deformed locknut		Flange nut, locknut, or bolt tapped into flange nut or d&t* hole	
	ft•lb	N•m	ft•lb	N•m	ft•lb	N•m
1/4	12	16	8	11	20	27
5/16	25	34	15	20	45	60
3/8	40	54	25	34	75	100
7/16	65	90	40	55	125	170
1/2	100	135	60	80	190	260
9/16	150	200	90	125	270	370
5/8	200	270	120	165	370	500
3/4	350	475	210	285	650	880
7/8	560	760	340	460	1250	1425
1	840	1140	500	680	1580	2145
1-1/8	1030	1400	320	840	1950	3645
1-1/4	1460	1980	880	1195	2760	3475

Grade 8: UNC or UNF Thread

Size	Hex nut, or bolt tapped into hex nut, or d&t hole		Hex top deformed locknut		Flange nut, locknut, or bolt tapped into flange nut or d&t* hole	
	ft•lb	N•m	ft•lb	N•m	ft•lb	N•m
1/4	14	19	10	14	24	33
5/16	30	40	18	25	50	70
3/8	55	73	35	50	90	125
7/16	85	115	50	70	140	190
1/2	130	175	80	110	220	300
9/16	190	260	110	150	310	420
5/8	260	355	160	245	430	585
3/4	450	610	270	365	750	1015
7/8	730	990	440	600	1210	1640
1	1090	1480	650	880	1320	2465
1-1/8	1550	2100	930	1260	2580	3500
1-1/4	2180	2955	1310	1780	3640	4935

*drilled and tapped

Metric Bolt and Cap Screw Torque Values

Size	Class 4.8				Class 8.8 and 9.8				Class 10.9				Class 12.9			
	Lubricated		Dry		Lubricated		Dry		Lubricated		Dry		Lubricated		Dry	
	N•m	ft•lb	N•m	ft•lb	N•m	ft•lb	N•m	ft•lb	N•m	ft•lb	N•m	ft•lb	N•m	ft•lb	N•m	ft•lb
M6	4.8	3.5	6	4.5	9	6.5	11	8.5	13	9.5	17	12	15	11.5	19	14.5
M8	12	8.5	15	11	22	16	28	20	32	24	40	30	37	28	47	35
M10	23	17	29	21	43	32	55	40	63	47	80	60	75	55	95	70
M12	40	29	50	37	75	55	95	70	110	80	140	105	130	95	165	120
M14	63	47	80	60	120	88	150	110	175	130	225	165	205	150	260	190
M16	100	73	125	92	190	140	240	175	275	200	350	225	320	240	400	300
M18	135	100	175	125	260	195	330	250	375	275	475	350	440	325	560	410
M20	190	140	240	180	375	275	475	350	530	400	675	500	625	460	800	580
M22	260	190	330	250	510	375	650	475	725	540	925	675	850	625	1075	800
M24	330	250	425	310	650	475	825	600	925	675	1150	850	1075	800	1350	1000
M27	490	360	625	450	950	700	1200	875	1350	1000	1700	1250	1600	1150	2000	1500
M30	675	490	850	625	1600	950	1650	1200	1850	1350	2300	1700	2150	1600	2700	2000
M33	900	675	1150	850	1750	1300	2200	1650	2500	1850	3150	2350	2900	2150	3700	2750
M36	1150	850	1450	1075	2250	1650	2850	2100	3200	2350	4050	3000	3750	2750	4750	3500

Do not use these values if a different torque value or tightening procedure is given for specific application. Torque values listed are for general use only. Check tightness of fasteners periodically.

Shear bolts are designed to fail under predetermined loads. Always replace shear bolts with identical property class fasteners.

Fasteners should be replaced with the same or higher property class. If higher property class fasteners are used, these should only be tightened to strength of original.

Make sure fastener threads are clean and that the threads are properly started. This will prevent them from cross threading or galling when tightened.

Tighten plastic insert or crimped type steel locknuts to approximately 50% of dry torque indicated on chart. Apply torque to the nut - not the bolt head. Tighten toothed or serrated type locknuts to full torque value.

LUBRICATED means coated with lubricant. DRY means plain or zinc plated without any type of lubricant.

Hydraulic Cylinder Bolt Torque Chart

Bolt Size (inch)	Bolt Part No.	Cylinder Repair Kit Part No.	Torque (ft•lb)	Torque (N•m)
1/2	106-096	190-165	90-100	120-135
5/8	106-097	190-166 & 190-169	180-200	245-270
3/4	106-098	190-167 & 190-170	290-325	395-440
7/8	106-122	190-172 & 190-174	410-640	550-625
1	106-145	190-175 & 190-189	630-700	855-950
1-1/8	106-146	190-177	770-850	1045-1170

As a general rule:

- 1/2-inch bolts are used in cylinders with 1-inch rods
- 5/8-inch bolts are used in cylinders with 1 1/4-inch rods
- 3/4-inch bolts are used in cylinders with 1 1/2-inch rods
- 7/8-inch bolts are used in cylinders with 1 3/4-inch rods
- 1-inch bolts are used in cylinders with 2-inch rods (one with 1 3/4-inch)
- 1-1/8-inch bolts are used in cylinders with 2-1/4-inch rods

IMPORTANT: Do not reuse cylinder piston bolts when rebuilding a hydraulic cylinder. Each cylinder repair kit contains a new bolt. Use it. Lubricate lightly and torque to value shown on chart.

SAE & ORS Hydraulic Fitting Replacement O-Ring Chart

Fraction Size	Dash Size	SAE (Port Seal O-Ring)		ORS (Face Seal O-Ring)	
		Thread Size	O-Ring P/N	Thread Size	O-Ring P/N
1/16	1	NA	NA	NA	NA
1/8	2	5/16 - 24	NA	NA	NA
3/16	3	3/8 - 24	NA	NA	NA
1/4	4	7/16 - 20	155-760	9/16 - 18	157-037
5/16	5	1/2 - 20	NA	NA	NA
3/8	6	9/16 - 18	155-705	11/16 - 16	157-038
1/2	8	3/4 - 16	155-706	13/16 - 16	157-039
5/8	10	7/8 - 14	155-707	1 - 14	157-040
3/4	12	1-1/16 - 12	155-709	1-3/16 - 12	157-017
7/8	14	1-3/16 - 12	155-747	NA	NA
1	16	1-5/16 - 12	155-748	1-7/16 - 12	155-714
1-1/4	20	1-5/8 - 12	155-702	1-11/16 - 12	NA
1-1/2	24	1-7/8 - 12	157-001	2 - 12	NA
2	32	2-1/2 - 12	NA	NA	NA
2-1/2	40	3 - 12	NA	NA	NA
3	48	3-1/2 - 12	NA	NA	NA

Thread size indicates the diameter of the threaded area in fractions of an inch and number of threads per inch.

NA = not a current CMW part numbered o-ring, or dash size does not occur in current CMW applications

SAE = straight thread fitting that seals by sandwiching a hard o-ring between a shoulder on the male part and an angular surface at the mouth of the female port.

ORS = o-ring face seal; a type of fitting that seals by compressing a hard, captive o-ring between two flat parallel faces, one grooved for the o-ring and the other plain to act as the sealing surface

JT1220

Related Publications

Component	Ass'y	P/N
Model:		
JT1220 Parts Manual		053-097
JT1220 Operators Manual		054-114
JT1220 Repair Guide (Service Manual)		N/A
JT1220 Technical Supplement.....		053-116
Engine:		
Cummins 60HP. Parts Manual – B3.3.	194-481	053-103
Cummins..... Operators Manual – B3.3.		055-069
Cummins... .. Repair Manual – B3.3		055-070

Filters

Engine:		
Air Filter Parts Ass'y		194-297
Element (primary)		194-759
Element (secondary).....		194-758
Oil Filter Element (spin-on) – Cummins B3.3.....		194-454
Fuel Filter Element (spin-on) – Cummins B3.3		194-461
Hydraulic:		
Oil Filter Element (1-1/2-UNF, spin-on, Replacement)		153-792
Element (1-1/2-UNF, spin-on, Break-In)		153-791

Optional Kits

O-ring Repair Kit - FLG, ORS & SAE (15 different O-rings)		190-051
O-ring Repair Kit - Field Service (46 different O-rings)		190-052



**Ditch
Witch**

Parts Manual Change Request

(Please print clearly)

Date: _____ Dealer No. (required): _____

Your Name: _____ Position: _____

Phone: _____ Fax: _____ E-mail: _____

Publication Information:

Parts Manual No.: _____ - _____ Model: _____

Illustration Part No.:	Manual Page No.:
1. _____ - _____	1. _____
2. _____ - _____	2. _____
3. _____ - _____	3. _____

Nature of Change Request:

- Text
- Graphics
- Missing Information

Describe change requested (if possible, include copy of publication page with changes marked.):

**Please fax completed form to
Parts Manual Department (580) 572-3525**

Thank you for taking the time to submit this request. We will contact you if further information is needed to process your request.

A Note To Ditch Witch Equipment Owners:

If your equipment was purchased through a Ditch Witch dealer, there is no need to read further.

However, if you purchased from any other source, please fill out the form on the reverse side and return it to us.

This will enable you to receive updates on this equipment as well as information on new products of interest.

Thanks for using Ditch Witch equipment.

(Please Fold Along This Line And Seal At Bottom With Tape)

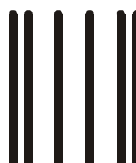

**NO POSTAGE
NECESSARY
IF MAILED
IN THE
UNITED STATES**

BUSINESS REPLY MAIL
FIRST CLASS PERMIT NO 23 PERRY OKLAHOMA

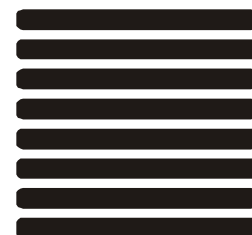

POSTAGE WILL BE PAID BY

The Charles Machine Works, Inc.
P.O. Box 66
Perry, Oklahoma 73077-9989



Ditch Witch® Registration Card

Please Type or Print All Information

Purchaser's Company Name

Attention

Street Address or P.O. Box

City County

State Zip Nation

()

Phone Number With Area Code

Model S rial Number

Attachments/Accessories Serial Numbers

Attachments/Accessories Serial Numbers

Attachments/Accessories Serial Numbers

Name of Ditch Witch Dealership

Your Signature